



BODY ELECTRIC SYSTEM

- This course introduces the new technology of Chery T21 vehicle, such as PEPS, rearview dynamic reversing imaging system, TELEMATICS system etc.
- This course shows the detailed information of engine system, transmission system, electrical system and chassis system.
- During the course learning, you'll share the maintenance experience in different part of T21, which can save your time and makes your work simple.
- After the course training, you will know Chery T21 vehicle well and help you do maintenance good.

- This course will take you about 16 hours;
- There will be a test at the end of training;
- Any question you have in the training process, please break me in;
- Please keep your phone mute.

Contents

| | | | |
|---|-------------------------------------|----|--------------------------|
| 1 | Vehicle communication system | 10 | External lighting system |
| 2 | PEPS system | 11 | Wiper system |
| 3 | Cruise control system | 12 | Instrument cluster |
| 4 | BCM | 13 | Audio system |
| 5 | Window & anti-pinch sunroof system | 14 | TELEMATICS system |
| 6 | Anti-theft alarm and locking system | 15 | Reversing radar system |
| 7 | Electric rearview mirror | 16 | Safety airbag system |
| 8 | Sunroof control system | 17 | Electric seat |
| 9 | Internal lighting system | | |



Vehicle communication system

1. CAN-bus
2. T21 communication data bus

1. CAN-bus

What's CAN bus?

CAN: Controller area network

In early 1980s, Germany Bosch develops a serial communication protocol to realize the real-time data exchange between various control units and testing instruments in modern cars.

- A half-duplex serial communication protocol;
- The communication medium can be double-stranded cable, co-axial cable or optical fiber cable;
- Communication baud rate 5K - 1MB/s;
- Communication distance 40m-10km.

1. CAN-bus

Why is the CAN bus installed in the car?

Conventional node communication method

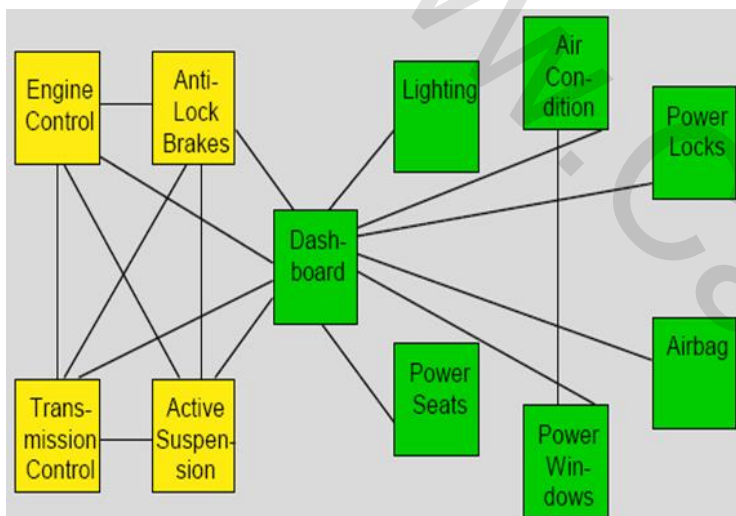

Point-to-point connection between controllers:

- Increased cost of materials
- Reduced reliability
- Increased weight of the car

CAN bus communication method

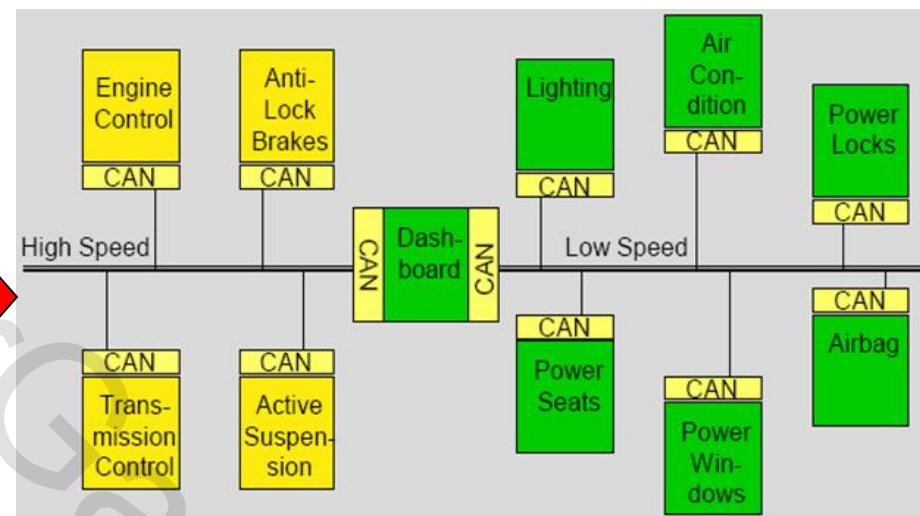

Connection between controllers by the serial bus

- Reduction of wiring harness and mounting space
- Reduction of manufacturing cost
- Improvement of real-time reliability of the system communication
- Improvement of expansion capacity and flexibility
- Adaption to unfavorable working environment

1. Vehicle communication system

1. CAN-bus

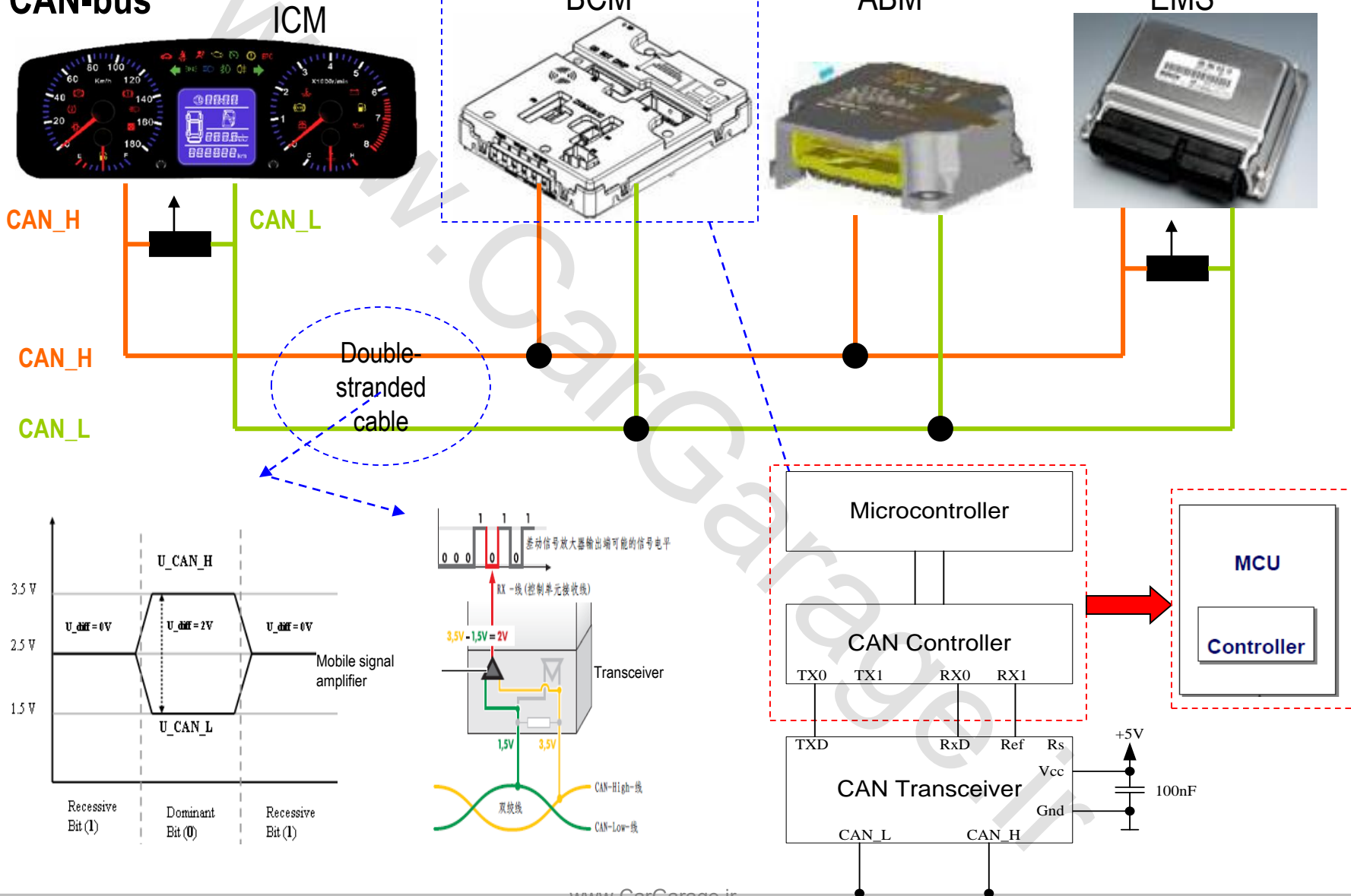

1. CAN-bus

CAN standard data frame format

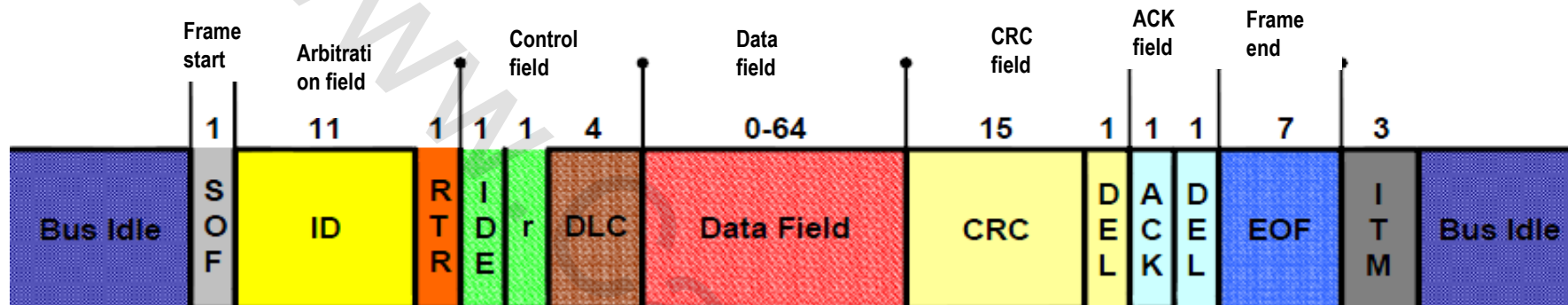

- SOF Mark the starting of a data frame, used for synchronization
- ID Determine the arbitration priority level of the message. The lower the ID value is, the higher the priority level
- RTR Used to distinguish the data frame and remote frame (Data frame: RTR=0; remote frame: RTR=1)
- IDE Used to distinguish standard frame and expansion frame (standard frame: IDE=0; expansion frame: IDE=1)
- R Reversed position 0
- DLC Including 4 bits, representing the number of bytes containing data in the data field
- Data Field With 0-8 bytes, determined by DLC, containing the information contained in CAN data frame
- CRC Used for CRC verification
- DEL Identify CRC sequence
- ACK Determine that the message has been correctly received by at least one node
- EOF Means the ending of data frame

1. Vehicle communication system

1. CAN-bus

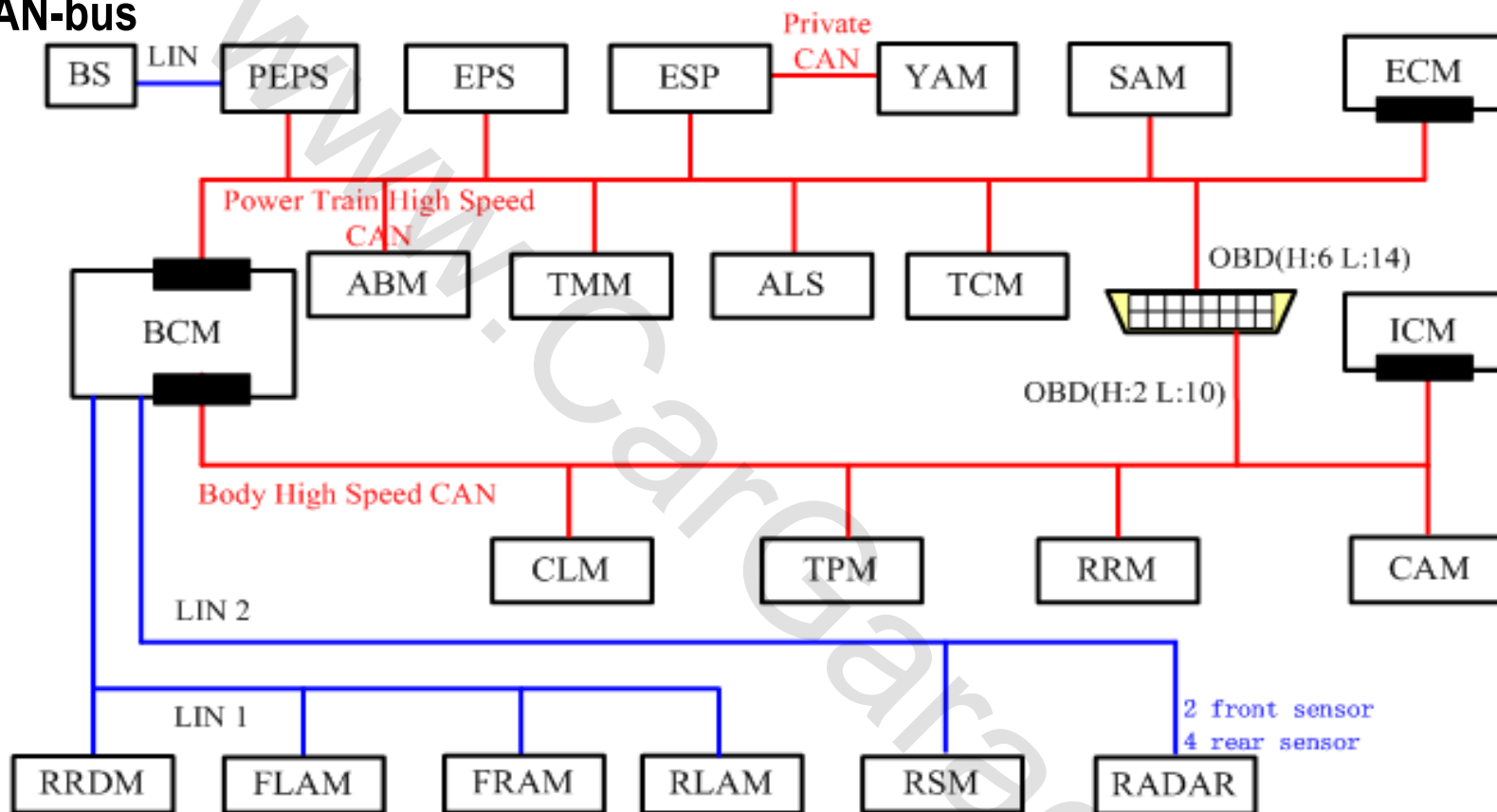

1. The power CAN is a 500kb/s transport network, and terminal resistor is located in ECM/BCM.
2. The body CAN is a 500kb/s transport network, and terminal resistor is located in ICM/BCM.
3. IMMO is built in PEPS system.
4. ESP system utilizes YAM which is integrated in ABM, and the dedicated CAN communication is provided. 120Ω resistors are located in these two modules.

1. Vehicle communication system

1. CAN-bus

| Type of node | Abbrebytion | | Full English name |
|--------------|-------------|-------------------------|-------------------------------|
| CAN | 1 | ECM | Engine Control Module |
| | 2 | EPS | Electronic Power Steering |
| | 3 | TCM | Transmission Control Module |
| | 4 | TPM | Tyre Pressure Module |
| | 5 | RRM | Radio Receiver Module |
| | 6 | ABM | Air Bag Module |
| | 7 | SAM | Steering Angle Module |
| | 8 | BCM | Body Control Module |
| | 9 | ABS | Anti-lock Break System |
| | | ESP | Electronic Stability Program |
| | 10 | PEPS | Passive Entry & Passive Start |
| | 11 | CLM | Climate Module |
| | 12 | IMMO | Immobilizer |
| | 13 | ICM | Instrument Cluster Module |
| | 14 | TMM | Torque Management Module |
| | 15 | ALS | Auto Leveling System |
| | 16 | CAM | Camera |
| 17 | YAM | Yaw acceleration Module | |

| Type of node | Abbrebytion | | Full English name |
|--------------|-------------|-------|-------------------------------|
| LIN | 1 | RSM | Rain Sensor Module |
| | 2 | RADAR | Radar Module |
| | 3 | FLAM | Front Left Anti-pinch Module |
| | 4 | FRAM | Front Right Anti-pinch Module |
| | 5 | RLAM | Rear Left Anti-pinch Module |
| | 6 | RRAM | Rear Right Anti-pinch Module |
| | 7 | BS | Base Station |

1. Vehicle communication system

2. T21 communication bus

– T21 power CAN bus

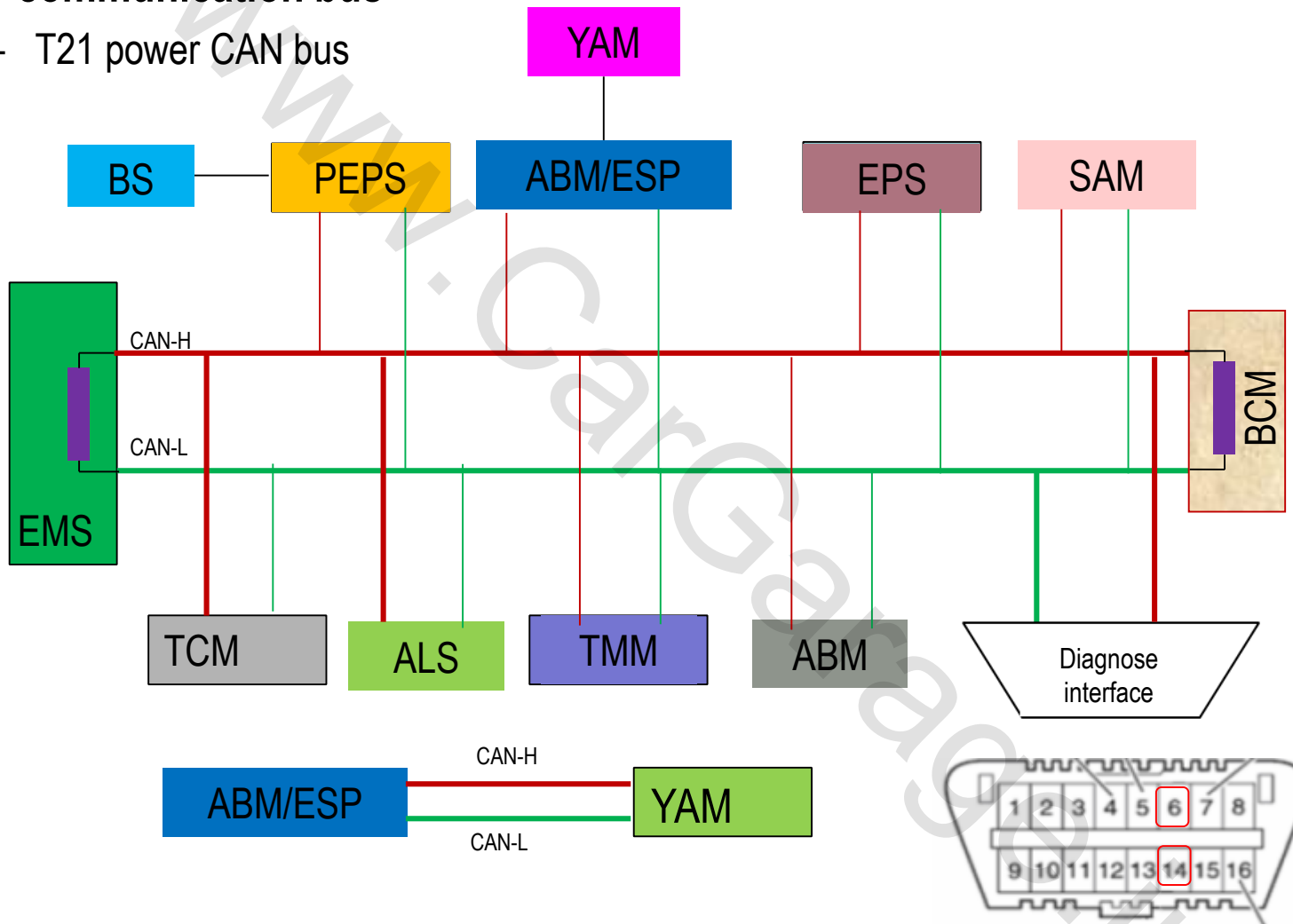

For YAM sensor dedicated CAN, a 120Ω resistor is located in YAM and ABM respectively.

1. Vehicle communication system

2. T21 communication bus

- T21 body CAN bus

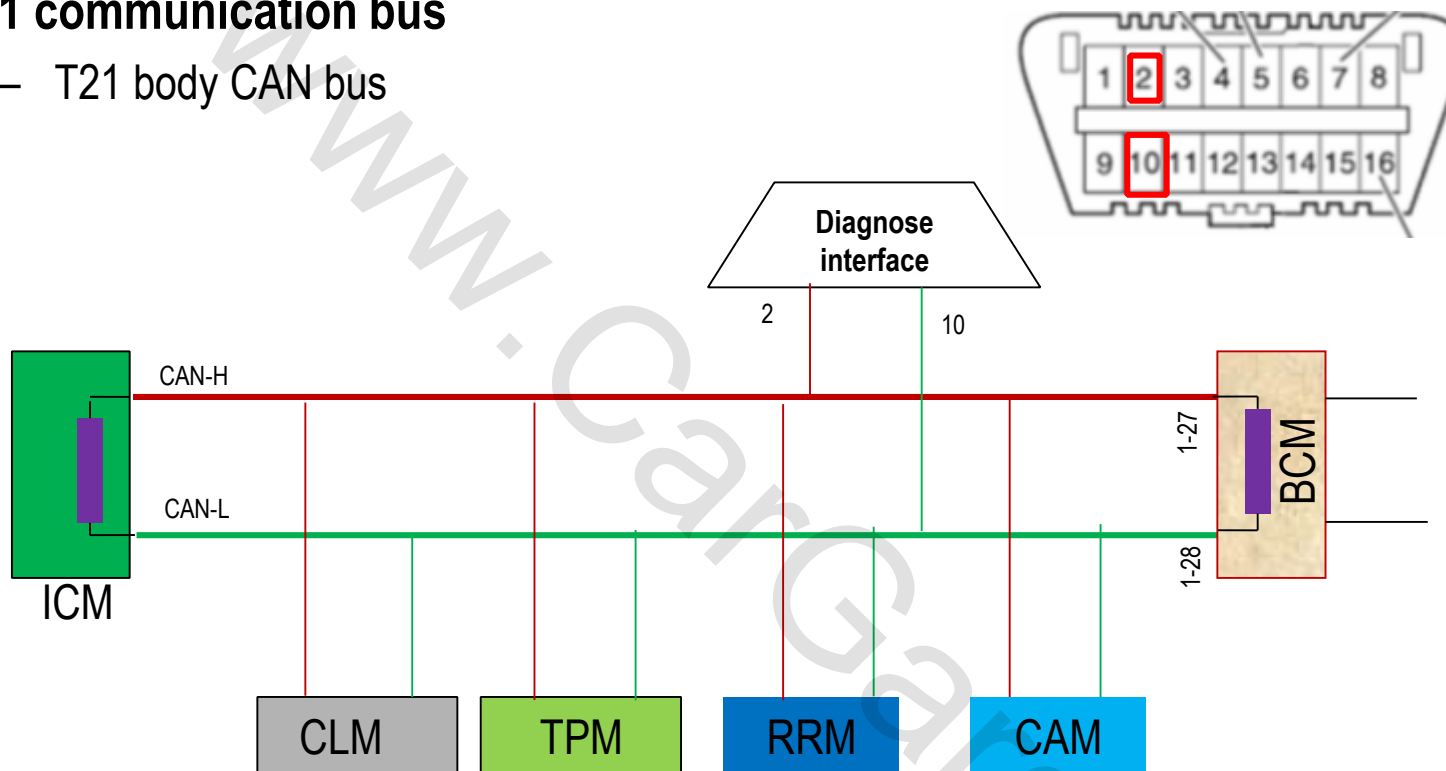

High-speed communication network

- Equipment of CLM double-zone automatic air conditioner;
- TPM and CAM are reserved modules now.

1. Vehicle communication system

3. T21 communication bus

- T21 Lin communication bus

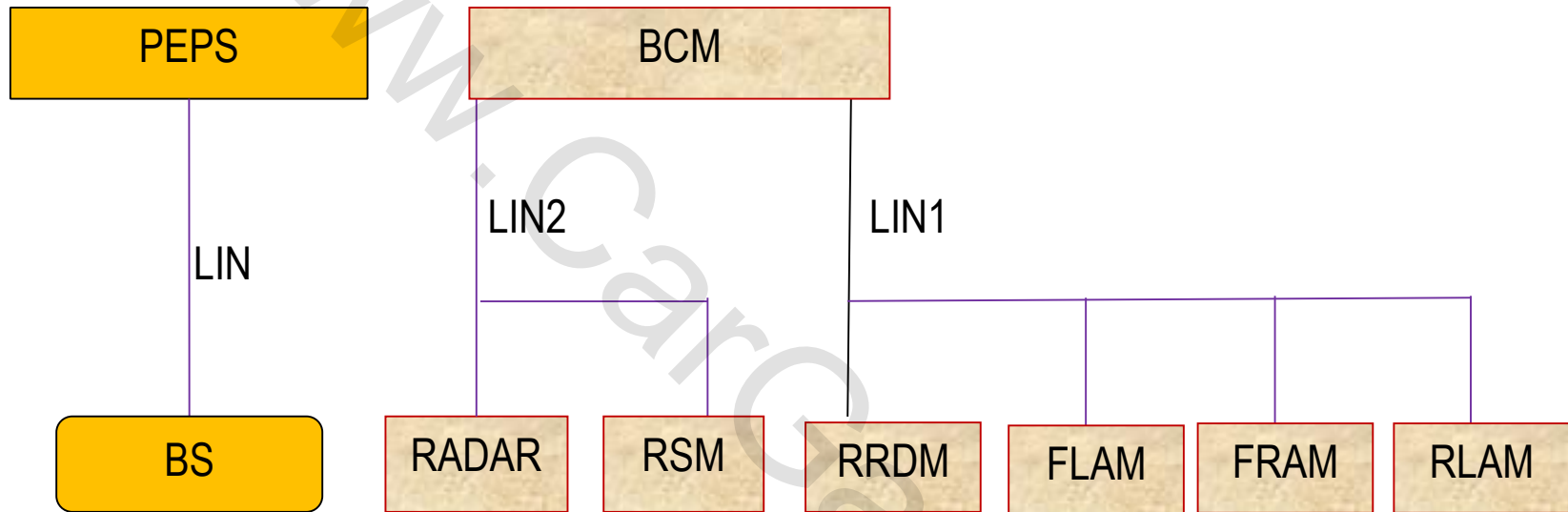

- RSM is now a reserved module;
- LIN1 is only equipped in the car with window anti-pinch function.

2. T21 communication bus

The configuration shall be specified if the T21 module is to be replaced.

- Body control module (BCM)
- Instrument cluster module (ICM)
- Electronic stability procedure (ESP)
- Passive entry& passive start system (PEPS)
- Engine management system (EMS)
- Electronic power steering system (EPS)
- Audio entertainment system (DVD) with Telematics

1. Vehicle communication system

2. T21 communication bus

T21 software configuration process

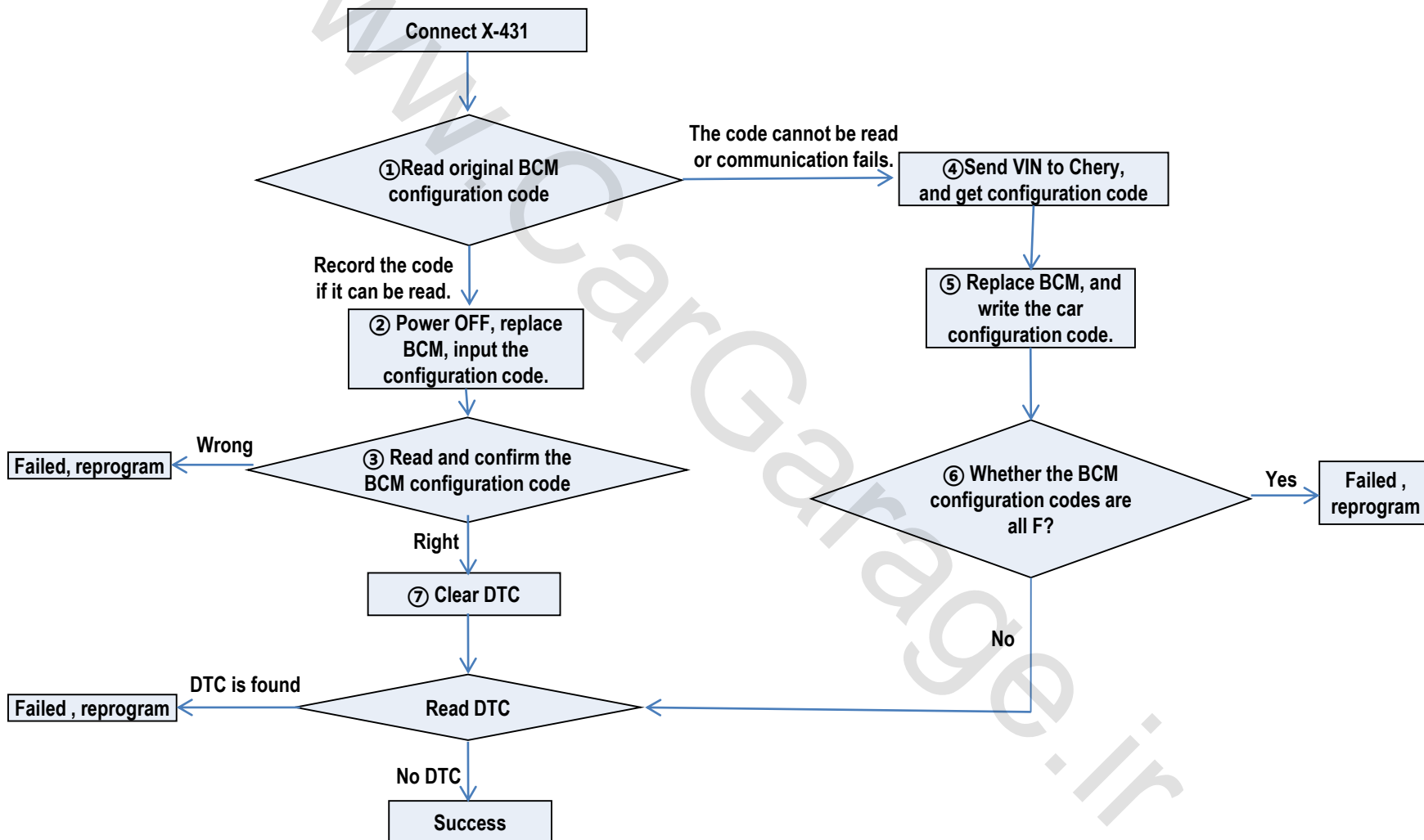

1. Vehicle communication system

2. T21 communication bus

Configuration procedure

Before replacement of body control module, enter “Body control system/Data stream reading/Body control module configuration information”, and read the configuration code of body controller. If the said code can be read, record the code, and execute ②; if the said code can't be read, BCM is damaged to cause failure of reading of configuration code or failure of connection, in which case ④ shall be executed.

After the body control module is replaced, enter “Body control system/Special operation/Write body control module configuration code”, and write the configuration code recorded in ① into the body control module.

Turn the ignition key to OFF and then to ON, and re-enter “Body control system/Data stream reading/Body control module configuration information”, read the configuration code of body control module and compare it with the code read in ①, and manually check whether the entry is correct; if correct, execute ⑦, and if not, execute ①.

The service station will check information on relevant characteristics of the car (such as chassis number), and provide it to the after-sales service department of the sales company and obtain the 196-digit complete vehicle configuration code from the after-sales service department.

2. T21 communication bus

Configuration procedure

Note: The after-sales service department will enter SAP system in accordance with relevant car information to find out the material number, and then find out the 196-digit complete vehicle configuration code in the MES system according to the material number.

After the replacement of body control module, enter “Body control system/Special operation/Write the complete vehicle configuration code”, and write the configuration code recorded in ④ into the body control module.

Enter “Body control system/Data stream reading/Body control module configuration information”, and read the configuration code of body control module. If all configuration codes are not only F, the writing is successful, execute ⑦, and if all configuration codes are only F, execute ⑤ again.

Enter “Body control system/Clear fault code”, and enter “Body control system/Read fault”. If the fault code is present, execute ⑤ again; if no fault code is present, disconnect the diagnostic apparatus, and the body control module is successfully replaced! The operation is finished!

2

PEPS system

1. General description
2. System elements introduction
3. System operation
4. Circuit diagram analysis
5. Notices in operation and maintenance

2. PEPS system

1. General description

General introduction of PEPS system

- PEPS (Passive Entry Passive Start)
- Passive Entry Passive Start is developed on the basis of the key entry system.

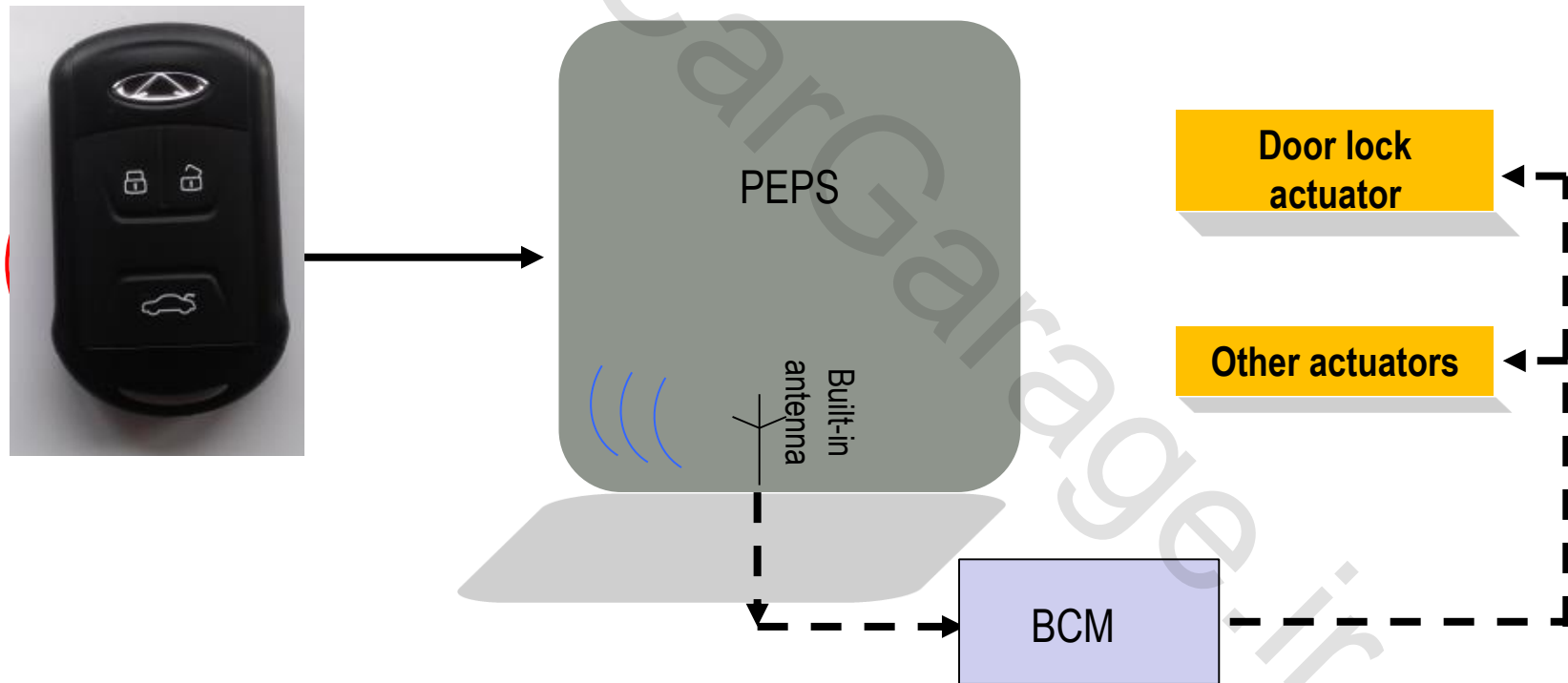

2. PEPS system

1. General description

Functions:

- Passive entry
- Ordinary remote control
- Passive start
- Trunk smart opening
- Engine immobilizer

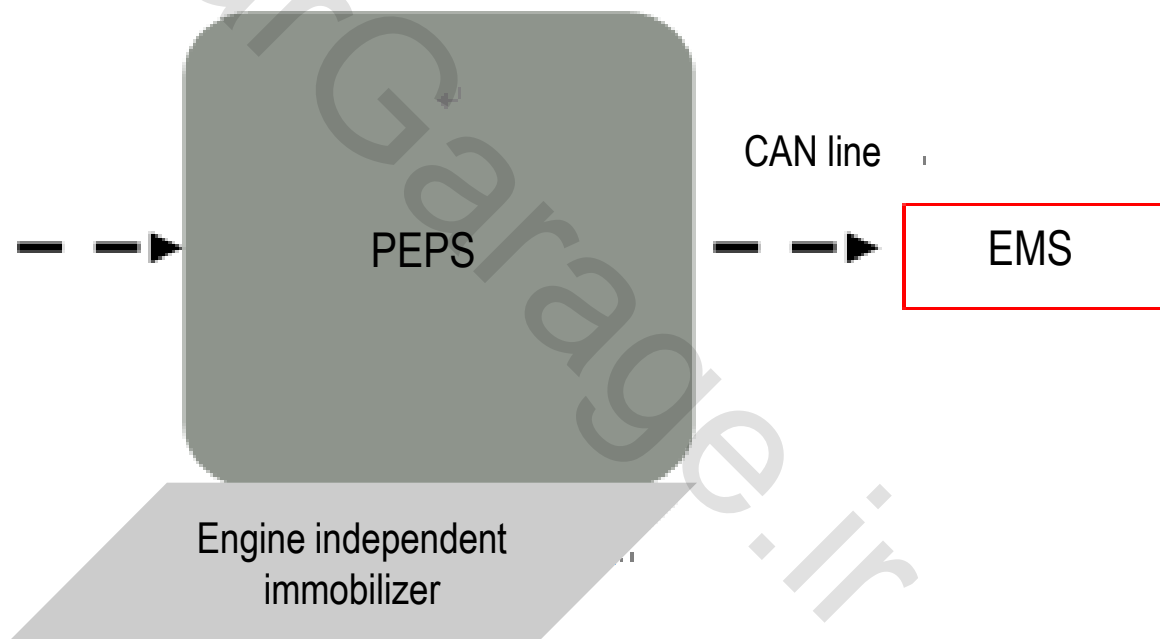
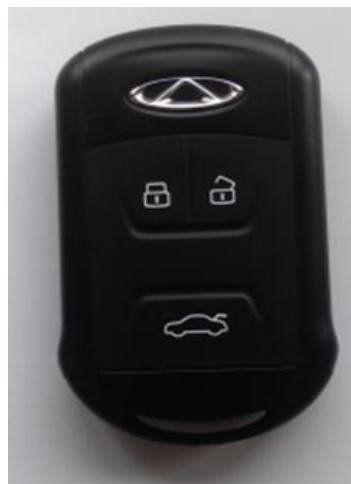

2. PEPS system

1. General description

Component:

- PEPS module;
- Receiving antenna of remote key (integrated in PEPS module);
- 3 antennae in the car are used locating the key;
- 1 spare antenna of immobilizer (immobilizer coil);
- 2 door handle switches (include antennae);

- Smart key;
- Passive start switch;
- Trunk opening switch.

2. PEPS system

2. System elements introduction

Low-frequency antenna

- Function: detect the smart key and realize the authorization of passive start

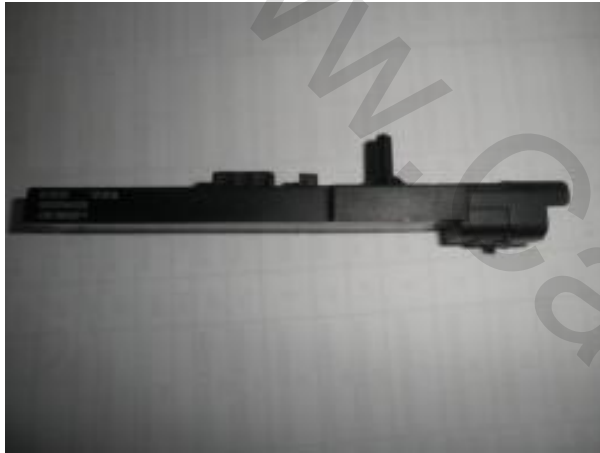

Antennae (in the cab and rear bumper)



Door handle



Immobilizer antenna



Door handle and door antenna

2. PEPS system

2. System elements introduction PEPS module

- The antenna built-in the PEPS module is used receiving radio frequency signal, and immobilizer is integrated in PEPS module.
- PEPS module communicates with BCM, EMS etc by high speed CAN system.

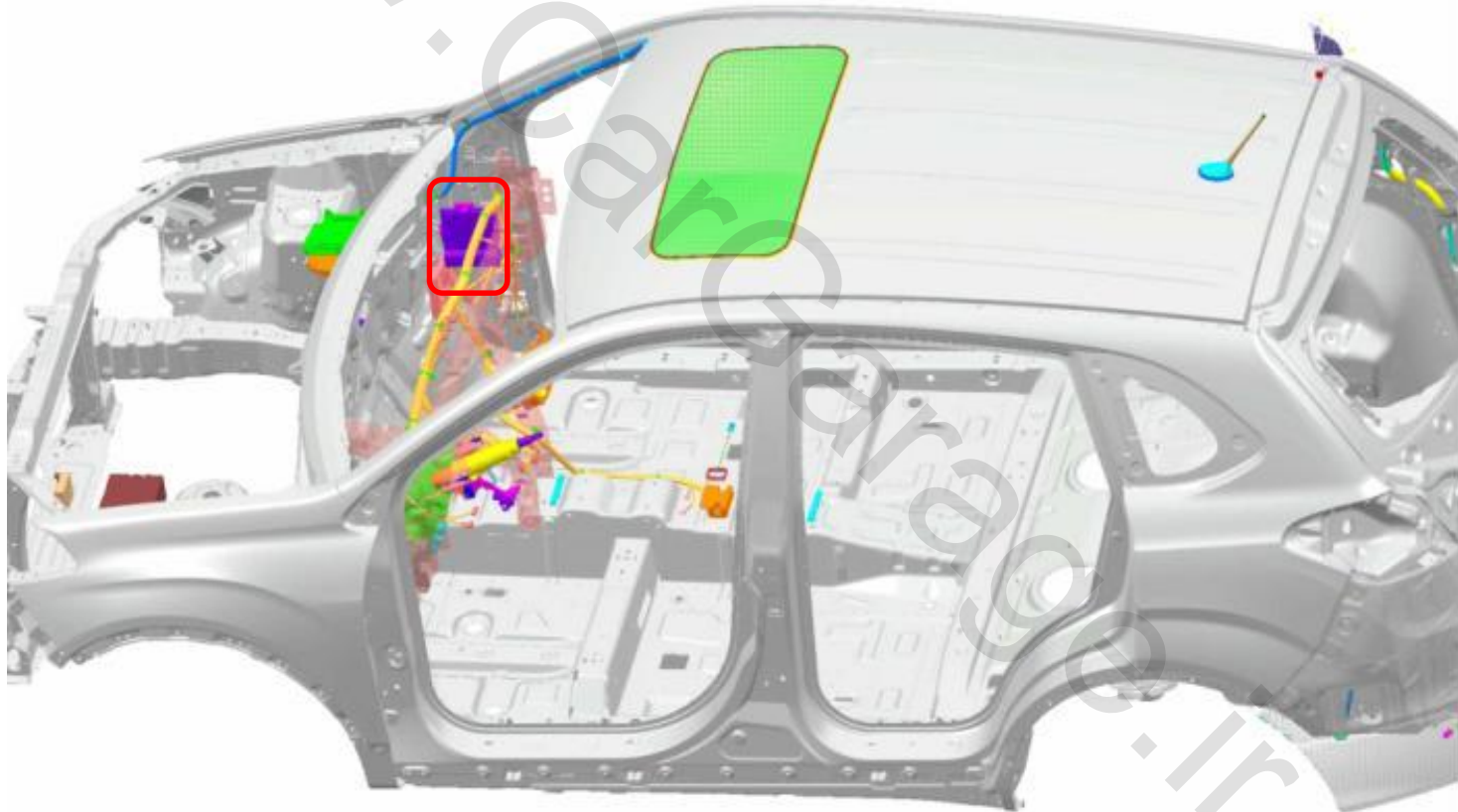

Location of PEPS module: Right A-pillar

2. PEPS system

2. System elements introduction

Smart key

– Structure



2. System elements introduction

Smart key detection range

- The smart key is detected range as the picture show.
- Notice: Some blind areas may exist at certain corners.

1. Low-frequency antenna —In the front of cab;
2. Low-frequency antenna —Inside FL door;
3. Low-frequency antenna —Inside FR door;
4. Low-frequency antenna —In the middle of cab;
5. Low-frequency antenna —At the end of cab;
6. Low-frequency antenna —Inside trunk lid;
7. Detection range of front door handle switch: $\leq 1.5\text{m}$;
8. Detection range of trunk lid low frequency antenna: $\leq 1.5\text{m}$.

- Green areas: the detection areas of passive start;
- Blue areas: the detection areas of passive entry;
- Yellow areas: the detection areas of trunk lid passive entry.
- If the smart key is covered by metal or stored together with electromagnetic wave transmitter, the electromagnetic wave of smart key may be shielded or interfered, resulting in abnormal performance of PEPS system.
- If battery voltage is low, the smart key can't be correctly identified even if it is located in the detection area, and PEPS system works abnormal. In this case, battery should be replaced.

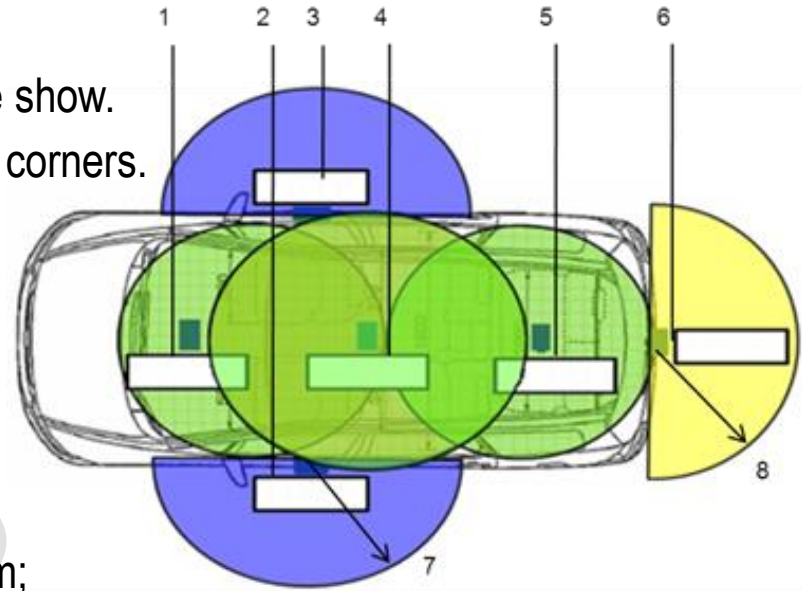

2. PEPS system

2. System elements introduction

Door handle switch

- Position



2. System elements introduction

Door handle switch

- Function: Door handle switch is used for lock/unlock door and open the trunk lid.
- Notice: the door lock can't be unlocked within 0.5s after it is locked, which is to protect the motors. So do not frequently operate these four door and the trunk.



2. System elements introduction

Starting switch

The starting switch is located at a noticeable position on the dashboard, used to change the car power supply mode and control the starter.



- The indicator lamp is not lit:
 The power supply mode is OFF and the brake pedal (CVT car) is not depressed or the engine has been started or is being started.
- The indicator lamp is lit (amber):
 The power supply mode is ACC or IGN, brake pedal (CVT car)
- The LED indicator lamp is lit (green):
 Startup conditions are met, and engine can be started by press starting switch.

| No. | Conditions and actions | Initial power supply mode | New power supply mode |
|-----|---|---------------------------|-----------------------|
| 1 | Key is in the car, brake pedal is not depressed (CVT), starting switch is pressed. | OFF | ACC |
| 2 | | ACC | IGN |
| 3 | | IGN | OFF |
| 4 | Key is in the car, brake pedal is depressed (CVT), gearshift lever is at P/N gear (CVT) ; the starting switch is pressed. | OFF | IGN+ engine startup |
| 5 | | ACC | IGN+ engine startup |
| 6 | | IGN | IGN+ engine startup |

2. PEPS system

3. System operation Lock/unlock by smart key



Within 10m

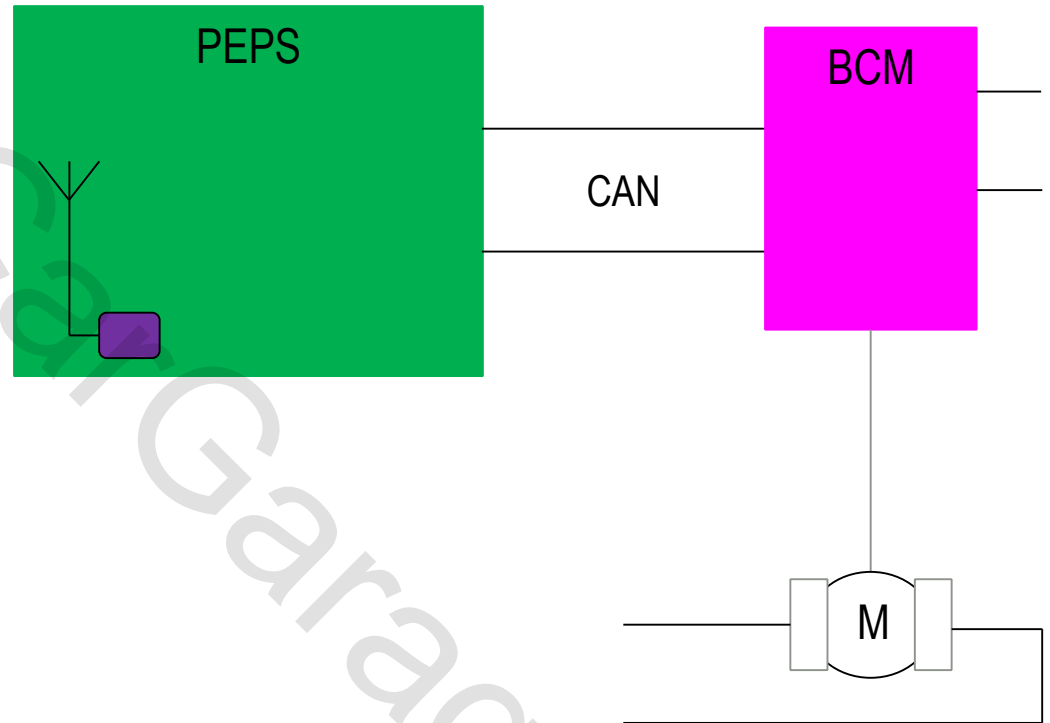

2. PEPS system

3. System operation Door lock/unlock

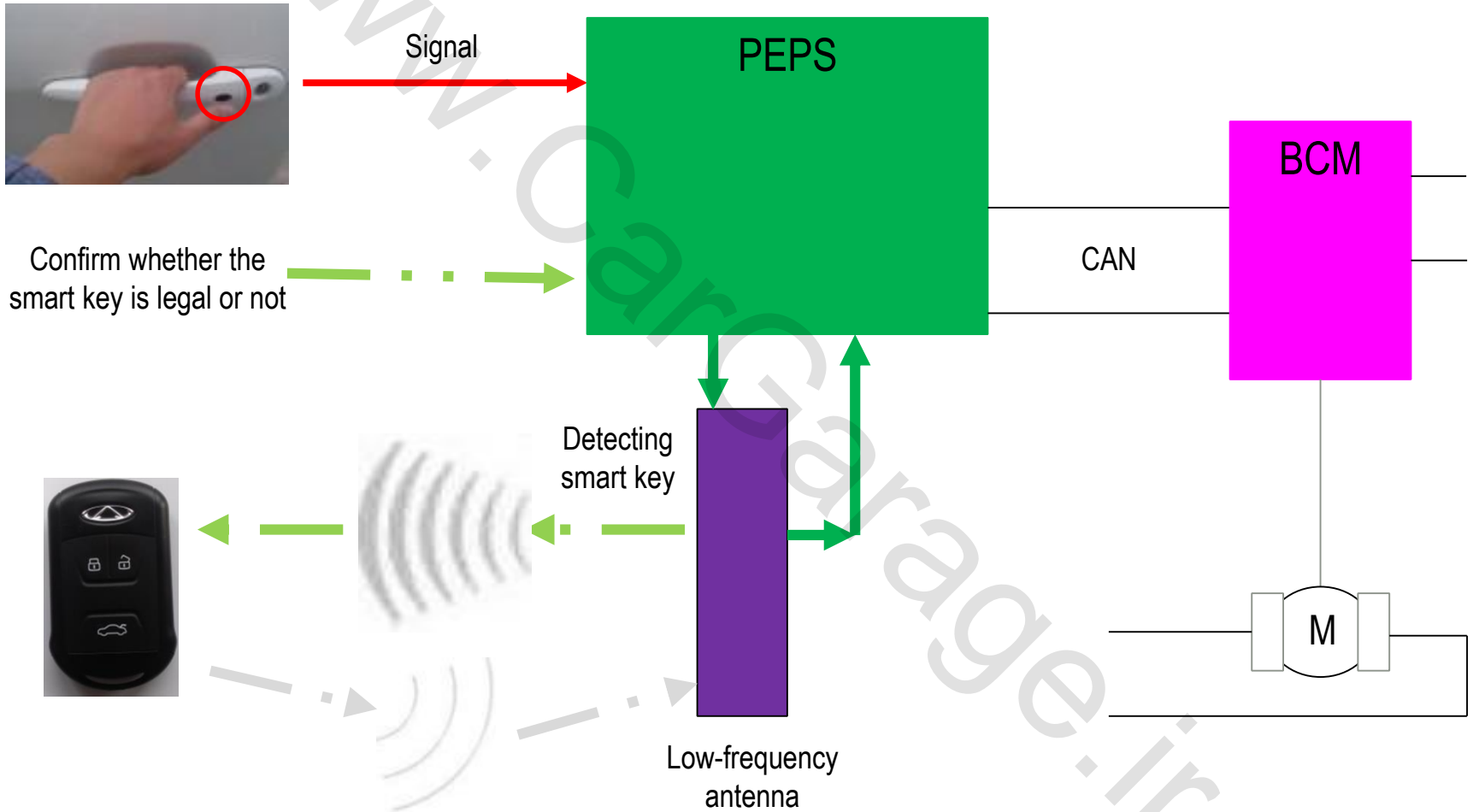

2. PEPS system

3. System operation Passive start

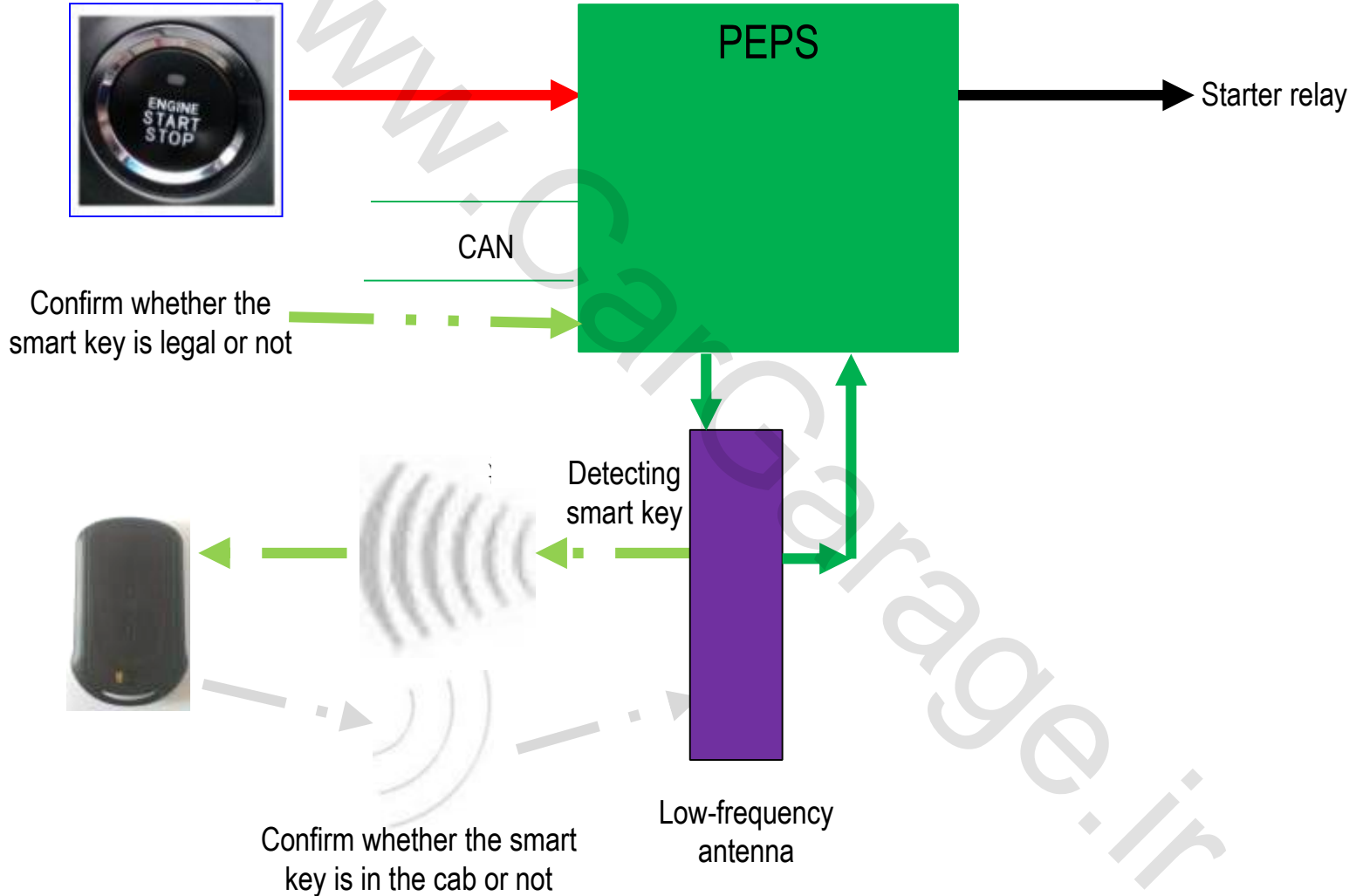

3. System operation

Passive start

The engine passive start function can be applied in any power supply mode (OFF, ACC, IGN).

The legal smart key is in the cab:

- 1) For CVT vehicle, with the gearshift lever at P or N, depress brake pedal and press the starting switch to start the engine;
- 2) For MT vehicle, depress clutch pedal and press the starting switch, engine can start.

Power supply mode switching

Each press passive start switch, the power supply mode will switching in turns.

Notice:

For CVT vehicle, if the gearshift lever is not at P, the power supply mode can't back to OFF.

2. PEPS system

3. System operation

Emergency engine start

If the smart key voltage is low or the radio frequency signal is seriously interfered, the passive start system will not work normally; at this moment, the system provides a standby engine startup means:

1. Flatly put the key into the bottom of rear cup holder with the key front side up, and do not depress the brake pedal (for CVT vehicle);
2. Press the starting switch (do not depress the brake pedal etc.), and the power supply mode will be changed to IGN, with following words indicated on the instrument: "The verification is successful and now the engine can be started";
3. Depress the brake pedal (for CVT vehicle), and press the starting switch to start the engine.

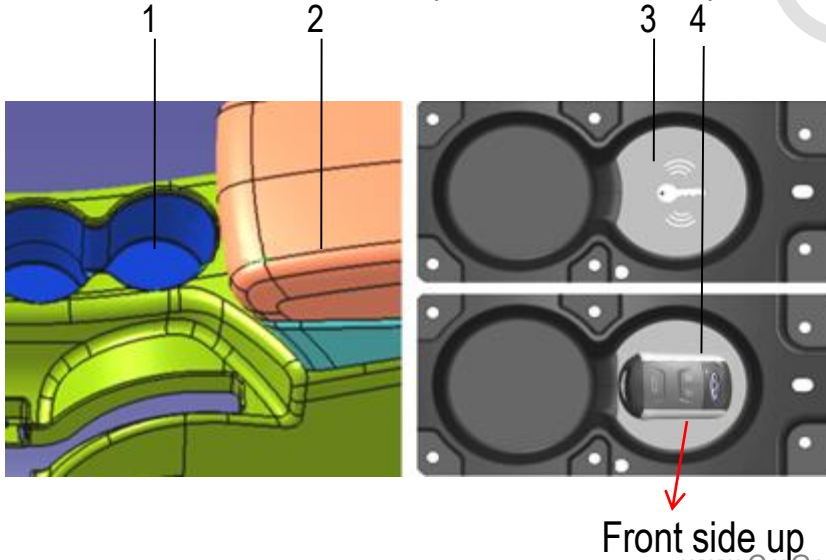

1. Cup holder;
2. Armrest box;
3. "Standby ignition key location symbol" on the bottom of the rear cup holder;
4. Smart key.

3. System operation

Passive stop

Emergency stop engine:

During engine running, if the engine is to be immediately stopped in any emergency, there are two approaches:

1. Quickly and continuously press the starting switch (3 times or above within 2s);
2. Press and hold the starting switch (more than 3s).

Warning:

The emergency stop of the working engine will cause serious influence on the normal operation of the vehicle. The emergency stop is not recommended except for any emergency.

2. PEPS system

4. Circuit diagram analysis

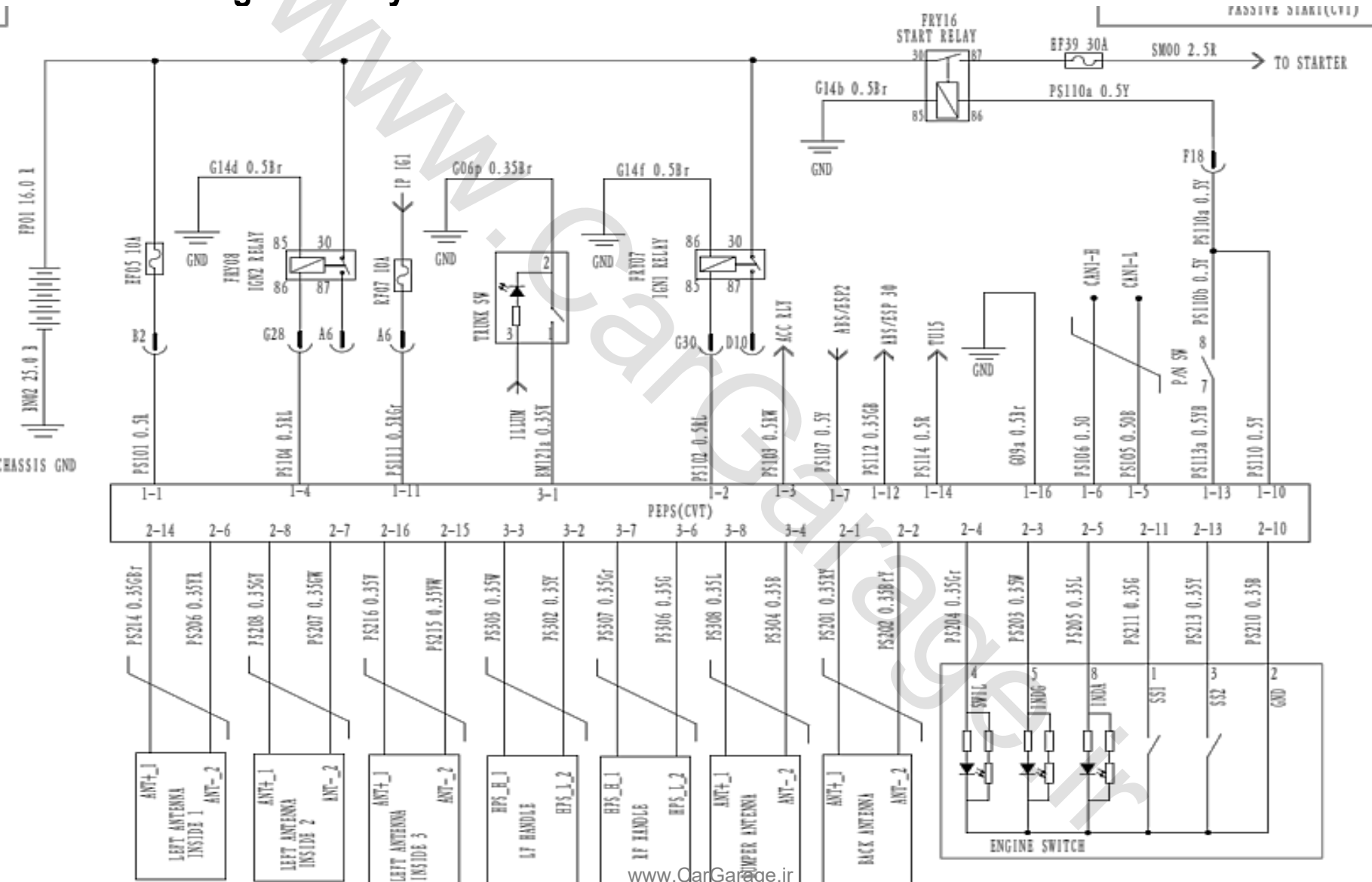

5. Notices in operation and maintenance

Smart key

- Unlocking with the smart key

When doors, engine hood and trunk lid are locked, press the unlock button, doors and trunk lid will be unlocked and the body anti-theft function deactivated.

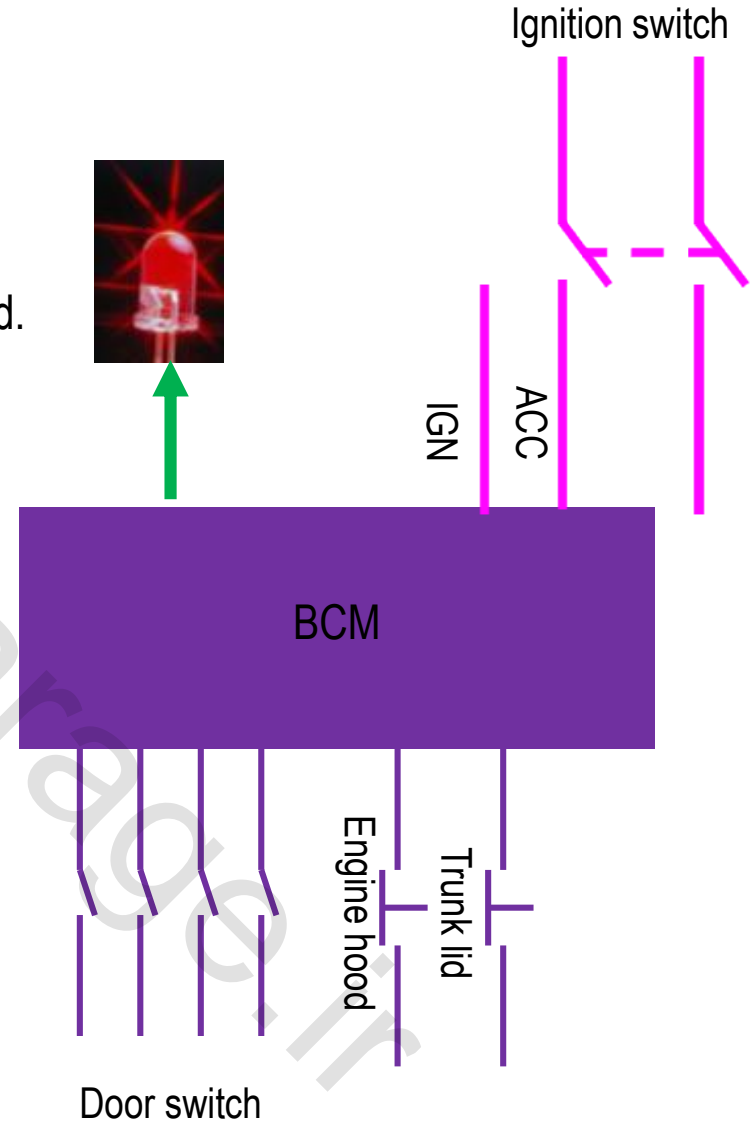

5. Notices in operation and maintenance

Smart key

When doors, engine hood and trunk lid are closed, press the lock button, doors and trunk lid will be locked and the body anti-theft function activated.

If any door is not closed properly, the locking system will not lock successfully.

If power supply is in ACC or IGN, to avoid misoperation, locking by the remote controller will be disabled.

If the door is closed but the engine hood or trunk lid is not closed properly, the locking system will lock the door but can't lock the engine hood or trunk lid, the body anti-theft function deactivated.

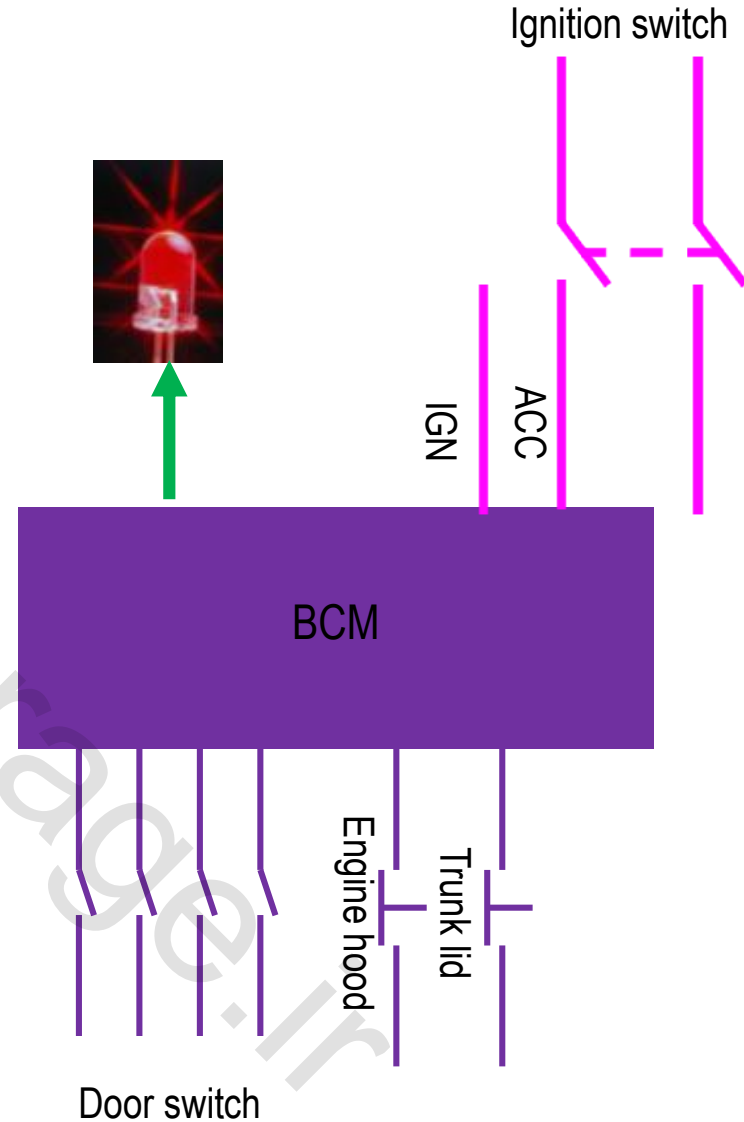

5. Notices in operation and maintenance

Smart key

- Release of trunk lid by remote controller
 - No matter the door is locked or unlocked, press the trunk button (about 1.5s), the trunk lid will be unlocked and opened (the open angle is small, the trunk lid should be pulled open slightly).
 - If doors and trunk lid are unlocked, the body anti-theft function deactivated.



5. Notices in operation and maintenance Unlock by mechanical key



Operate knob on the back of the key, remove the mechanical key, insert it into the FL door lock plug, and rotate it to left or right to lock or unlock the car.

5. Notices in operation and maintenance

Replacement of battery

Operate the knob on the back of the key and remove the mechanical key.



Open the smart key cover by flat head screwdriver.



Remove circuit board and battery holder.



Remove battery by flat head screwdriver.



Fit new battery (3V-CR2032) into battery holder properly.

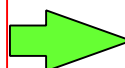

Fit battery holder into circuit board properly



Tightly fit the key cover, and insert the mechanical key into the smart key.



5. Notices in operation and maintenance

Notice:

1. As for PEPS vehicle, the remote control function is designed to satisfy locking/unlocking requirements of the user at the distance more than 1.5m from the car. When the user takes along the smart key enter the zone of passive entry, it is allowed to lock/unlock the car by door handle.
2. The frequency band of remote controller can be also used for other wireless devices (such as certain wireless electrical toys, medical devices, remote control devices). If the co-channel interference is encountered to disable remote controller, the mechanical key still can lock or unlock the car.
3. If you press the unlock button on the remote controller unintentionally, the door will be unlocked. The effective working distance of the remote controller depends on the surrounding environment, and typically it is about 10m.
4. When you leave the car, please ensure that the car is locked to prevent malicious locking inference.
5. Do not leave the key in the car.

5. Notices in operation and maintenance

Notice of passive entry:

1. To ensure the safety, when doors lock by remote controller, central control or mechanical key, if the smart key is in the cab, the system will disable the door handle switch. In this case, doors can lock/unlock by remote controller.
2. To ensure the correct lock/unlock action of the door handle switch, do not operate the door handle switch rapidly and continuously, do not quickly and continuously operate trunk lid switch.
3. In certain cases, for example, if the key is too close to the door, it may be deemed to be in the cab by the system to disable the door handle switch and the passive entry function. In this case, it should use remote controller to unlock/lock the door.

In following cases, PEPS may be disabled:

- Transmitting station
- The key is shielded by the metal
- Battery charge depletion

Remark: Even if in the detection area, the system may be disabled due to signal interference.

5. Notices in operation and maintenance

Notice of starting switch

1. In-car key detection zone: Do not put the key in the storage box on the door, nor put it in the corner close to the vehicle outside, for these areas may be detected by the low-frequency antenna in the car to disable passive start system.

2. For the CVT car: With the key in the car and the gearshift lever at P or N, if the brake pedal is depressed, the engine still can't be started; in this case, press the starting switch to turn the power supply mode to "ACC". Hold the starting switch ($\geq 15s$), and the system will neglect the brake pedal signal and the engine can be started.

Warning: Please go for service in Chery service station in time.

3. During engine start, if the brake pedal (CVT cars) is released, the system will stop engine starting to ensure the starting safety. In this case, please depress brake pedal again, and press the starting switch to start the engine.

5. Notices in operation and maintenance

IMMO system

System components: Smart key, ECU, TCU(for CVT vehicle), PEPS module.

If any part of the system is damaged and replaced, the system should do the program match.

① Replace smart key

There are two ways to match smart key and system: add new key, add old key.

“Add new key” is match the blank key (the key which has never been correlated with any system) and the system. It allows add new key in addition to the old key.

“Add old key” is to add an old key to enable the user to delete all keys in the after-sales service station to disable the missing key and then add keys by adding old keys.

Operation procedure of “Add new key”:

1. Read the VIN by scanner from ECU, and apply the PIN from CHERY.
2. Put the key in cup holder which marked with key icon, enter the match program interface, select “Add new key” menu, input PIN.
3. After “Add new key” procedure is finished, press the unlock button and check whether the left and right turning lamps on the instrument cluster are flashing or not. If flashing, the new key is matched successfully, otherwise, the matching is failure.

5. Notices in operation and maintenance

Operation procedure of “Add old key” :

1. Read the VIN by scanner from ECU, and apply the PIN from CHERY.
2. Enter the matching interface, select “delete all keys” menu.
3. Put the key in cup holder which marked with key icon, enter the match program interface, select “Add old key” menu, input PIN, and the diagnostic apparatus will automatically execute “Add old key” procedure.
4. After “Add old key” procedure is finished, press the unlock button and check whether the left and right turning lamps on the instrument cluster are flashing or not. If flashing, the new key is matched successfully, otherwise, the matching is failure.

Notice:

1. To apply “Add old key”, all the keys should do the match one by one, otherwise, other matched key will not work.
2. No matter “Add new key” or “Add old key”, only one key can be kept in the cab, and the key must be put on the key icon in the cup holder.

5. Notices in operation and maintenance

Operation procedure of replace ECU

1. Read the VIN by scanner from ECU, PEPS module, TCU, and apply the PIN from CHERY.
2. After the new ECU is successfully installed, press ignition (IG) switch to supply power.
3. Enter the matching interface, select "Program EMS" menu, and input the VIN and PIN as scanner interface reminding. After successfully program EMS, the scanner screen shows "Program EMS succeed".
4. Depress the brake pedal (CVT car), and press the ignition switch to start engine. If yes, the matching operation is successful, otherwise, it is failed.

5. Notices in operation and maintenance

Operation procedure of replace TCU (Only for CVT car)

1. Read the VIN by scanner from ECU, PEPS module, TCU, and apply the PIN from CHERY.
2. After the new TCU is successfully installed, press ignition (IG) switch to supply power.
3. Enter the matching interface, select "Program TCU" menu, and input the VIN and PIN as scanner interface reminding. After successfully program TCU, the scanner screen shows "Program TCU succeed".
4. With the car power supply in IGN mode, depress the brake pedal to check whether the gearshift lever can be easily shifted from P to other gear. If yes, the replacement is successful, otherwise, it is failed.

5. Notices in operation and maintenance

Operation procedure of replace PEPS module

1. Read the VIN by scanner from ECU, PEPS module, TCU, and apply the PIN from CHERY.
2. After the new PEPS module is succeed installed, press ignition (IG) switch to supply power.
3. Enter the matching interface, select "Reset EMS " menu. Input PIN as scanner reminding, after ECU is successfully reset, the scanner screen shows " Reset EMS succeed".
4. For CVT vehicle, select "Reset TCU" menu. Input PIN as scanner reminding, after TCU is successfully reset, the scanner screen shows " Reset TCU succeed".
5. Do the operation procedure of add new key, replace EMS, replace TCU one by one.

Notice:

1. If PEPS module is not matched, there are 50 chances to shift the ignition switch power supply mode from OFF to ON; after 50 trials, PEPS module will be disabled. Therefore, do not turn on the power supply randomly if PEPS module is not matched.

5. Notices in operation and maintenance

I. No DTC repair

- If there is trouble in PEPS system without DTC, this is called No DTC repair.

No DTC troubles in the PEPS system are generally classified into following categories:

- The indicator lamp on instrument cluster is not lit or is long lit (the wiring problem or the indicator lamp is damaged).
- Solution: Check corresponding parts in accordance with fault symptoms, and service manual can help.

5. Notices in operation and maintenance

II. Random trouble repair

- In electronic system, the instant poor contact may occur in the electric circuit and at input/output signal to cause random trouble . Sometimes, the faults may disappear automatically, so the problem can't be identified easily.
- In the case of random fault happens, the fault can be simulated in the way below to check whether the fault reoccurs.

| No. | Possible causes | Fault simulation | Remarks |
|-----|--|---|---|
| 1 | When vibration may be the major cause | 1. Lightly shake PEPS system connectors 2. Lightly shake PEPS system wiring harness | If wiring harness is twisted off or broken due to high tension, please replace part |
| 2 | When temperature may be the major cause | 1. Use the air heater to heat the component which is deemed to be defective 2. Use the cold spray to check whether there is any cold welding | |
| 3 | When high electrical load may be the major cause | 1. Turn on all electric switches, including headlamps and wiper, to have electric system work at high load | |

5. Notices in operation and maintenance

Description on fault codes of PEPS system

| DTC | Description on the fault code | Definition of category of fault | Type of fault |
|----------|---------------------------------------|---------------------------------|----------------|
| B1300-00 | EEPROM error in control module | Without sub-category | Internal fault |
| B1301-00 | Failure of IMMO and ECM verification | Without sub-category | Internal fault |
| B1302-00 | No writing of VIN | Without sub-category | Internal fault |
| B1303-00 | Antenna is subject to interference | Without sub-category | Internal fault |
| B1304-00 | No key is detected | Without sub-category | Input fault |
| B1305-00 | No stored key information in IMMO | Without sub-category | Internal fault |
| B1306-00 | No writing of SC | Without sub-category | Internal fault |
| B1500-13 | Driver side low frequency antenna | Open circuit | Input fault |
| B1501-13 | Passenger side low frequency antenna | Open circuit | Input fault |
| B1502-13 | Front internal low frequency antenna | Open circuit | Input fault |
| B1503-13 | Middle internal low frequency antenna | Open circuit | Input fault |
| B1504-13 | Rear internal low frequency antenna | Open circuit | Input fault |
| B1505-13 | Rear bumper low frequency antenna | Open circuit | Input fault |
| B1506-00 | Engine switch | Anomaly | Input fault |
| B1507-00 | Ignition circuit | Anomaly | Input fault |

5. Notices in operation and maintenance

Description on fault codes of PEPS system

| DTC | Description on the fault code | Definition of category of fault | Type of fault |
|----------|--------------------------------------|---------------------------------|----------------|
| B1508-00 | ACC circuit | Anomaly | Input fault |
| B1509-00 | Brake signal | Anomaly | Input fault |
| B150A-00 | Vehicle speed signal | Anomaly | Input fault |
| B1510-00 | Wheel speed signal | Anomaly | Input fault |
| B1514-00 | Starting power supply input anomaly | Anomaly | Input fault |
| B1515-45 | Failure of ROM check sum | Overhigh current | Input fault |
| B1516-19 | HUS overload | Overhigh current | Input fault |
| B1517-23 | HUS switch adhesion | Low signal level | Input fault |
| U0073-88 | Control module communication bus off | Bus off | Network fault |
| U0100-87 | Fault of communication with EMS | Message lost | Network fault |
| U0101-87 | Fault of communication with TCM | Message lost | Network fault |
| U0129-87 | Fault of communication with BSM | Message lost | Network fault |
| U0140-87 | Fault of communication with BCM | Message lost | Network fault |
| U1300-55 | Software configuration error | Configuration error | Internal fault |

3

Cruise control system

1. General description
2. Working principle

3. Cruise control system

1. General description

Components of cruise control system:

- 1. Cruise control switch
- 2. BCM
- 3. ECU
- 4. Electronic throttle
- 5. Brake switch

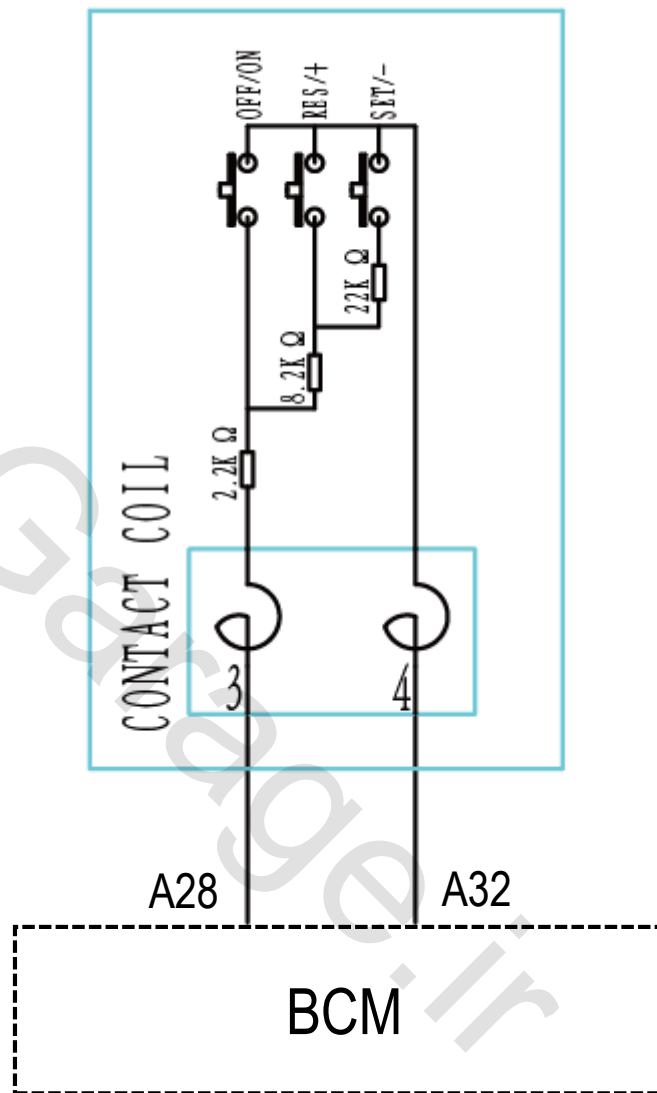

3. Cruise control system

2. Working principle

Working principle of cruise control system

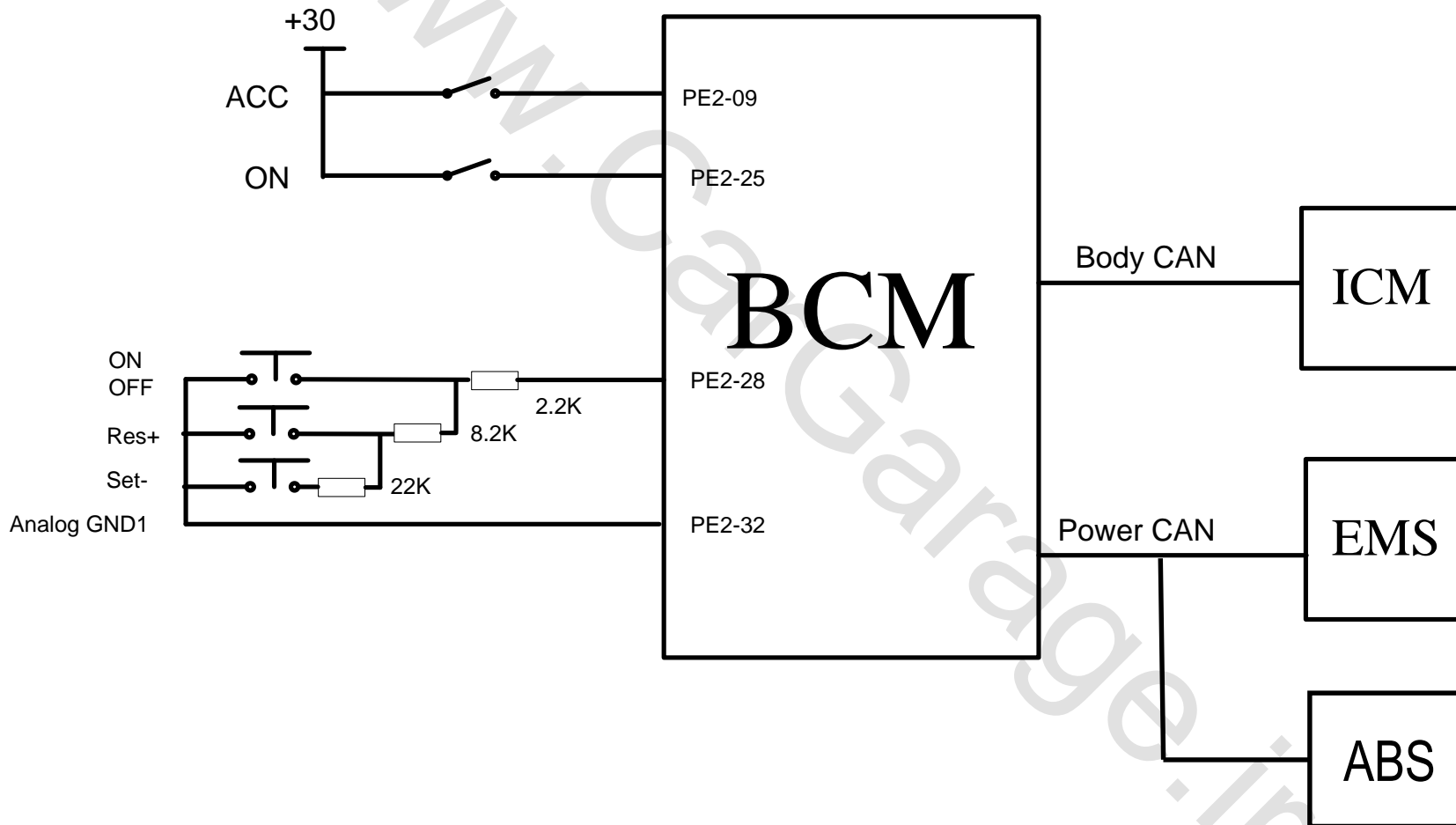

2. Working principle

Working principle of cruise control system

- IGN-ON, press ON/OFF switch, and BCM will continuously send CAN signal “Main switch=1” to Power CAN. Press cruise ON/OFF switch again and “Main switch=0”.
When IGN SW just turns to ON position, the initial cruise mode is off, CAN signal “Main switch=0”.
- IGN-ON, press and hold “RES/+”, and BCM will send CAN signal “RES/+ =1” to Power CAN; release the switch, and BCM will send CAN signal “RES/+ =0” to Power CAN.
- IGN-ON, press and hold “SET /-”, and BCM will send CAN signal “SET /- =1” to Power CAN; release the switch, and BCM will send CAN signal “SET /- =0” to Power CAN.

2. Working principle

Function description of cruise control system

To lessen driver's burden to depress accelerator pedal, for CVT vehicle, the cruise control system can make the vehicle driving at a constant speed between 40km/h and 130km/h where the engine power permits so.

1. With IGN SW ON, press cruise switch ON, and the cruise indicator lamp on instrument cluster will be lit and flash (pre-cruise, that's normal). During driving, if the vehicle speed is between 40km/h and 130km/h, press the cruise switch SET/-, the vehicle will perform the fixed-speed cruise driving at the speed set by pressing SET/- (in this case, do not depress the accelerator pedal. The cruise system will automatically control the openness of throttle pedal depending on road conditions). Cruise indicator lamp on shows that the cruise mode is activated. If the cruise indicator lamp continues flashing, the cruise mode is not activated. Please try again(if it fails again, please contact Chery service station for troubleshooting).
2. In the cruise mode, depress the accelerator pedal (during this process, the cruise indicator lamp will remain lit), and the vehicle speed will increase. Release accelerator pedal, the vehicle will restore the cruise speed before accelerator pedal is depressed.
3. In the cruise mode, depress the accelerator pedal (during this process, the cruise indicator lamp will remain lit), and the vehicle speed will increase. Release accelerator pedal, press the cruise switch SET/- and the vehicle will cruise at a new speed.

2. Working principle

Function description of cruise control system

4. In the cruise mode, each short press RES/+ ($\leq 0.5s$) (during pressing, the cruise indicator lamp will be lit), vehicle cruising speed will increase 2km/h. In the cruise mode, long press RES/+ ($\geq 0.5s$) (during pressing, the cruise indicator lamp will be lit), and the vehicle speed will increase constantly. Release RES/+, vehicle speed will stop increase, and vehicle runs at the speed set at releasing RES/+ (It is not recommended to press RES/+ long continuously, for this may lead to a constant increase of vehicle speed, which is liable to cause accidents).

5. In the cruise mode, each short press RES/- ($\leq 0.5s$) (during pressing, the cruise indicator lamp will be lit), vehicle cruising speed will decrease 2km/h. In the cruise mode, long press RES/+ ($\geq 0.5s$) (during pressing, the cruise indicator lamp will be lit), and the vehicle speed will decrease constantly. Release RES/-, vehicle speed will stop decrease, and vehicle runs at the speed set at releasing RES/-.

6. In the cruise mode, depress brake pedal, and the cruise indicator lamp on instrument cluster will flash (pre-cruise, that's normal), and the vehicle speed will decrease. If vehicle speed is lower than 40km/h, release brake pedal, press RES/+, and the vehicle will restore the cruise mode before depress brake pedal, with the cruise indicator lamp on the instrument lit long.

2. Working principle

Function description of cruise control system

7. In the cruise mode, depress brake pedal, and the cruise indicator lamp on instrument cluster will flash (pre-cruise, that's normal), and the vehicle speed will decrease. If vehicle speed is lower than 40km/h, release brake pedal and press RES/+, the vehicle will not restore the cruise mode before depress brake pedal. But depress accelerator pedal until the speed is higher than 40km/h, release accelerator pedal, and press RES/+, the vehicle will restore the cruise mode before depress brake pedal, the cruise indicator lamp lit long.

8. In the case of any fault which may adversely influence the cruise safety, the cruise mode will be disabled with cruise indicator lamp flashes. Please go for service in Chery service station.

9. In the cruise mode, press OFF, the cruise mode will exit, and the cruise indicator lamp off.

4

BCM

1. Mounting position
2. Principle block diagram
3. Function description

4. BCM

1. Mounting position



BCM

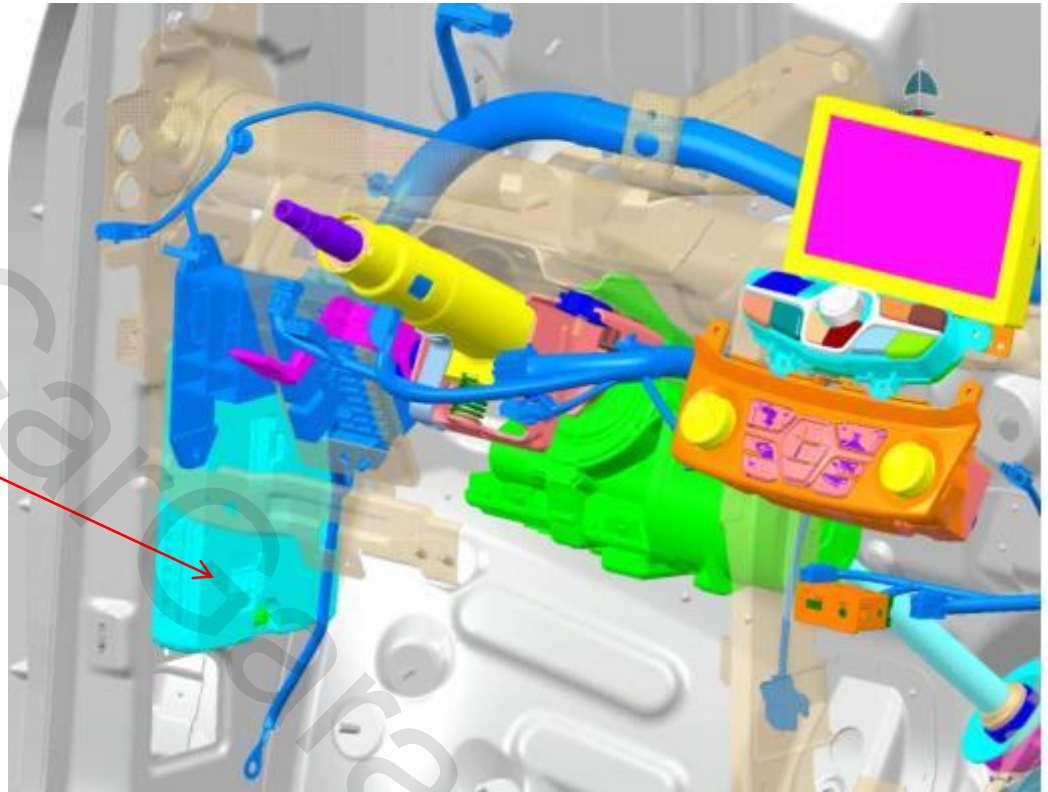

2. Principle block diagram

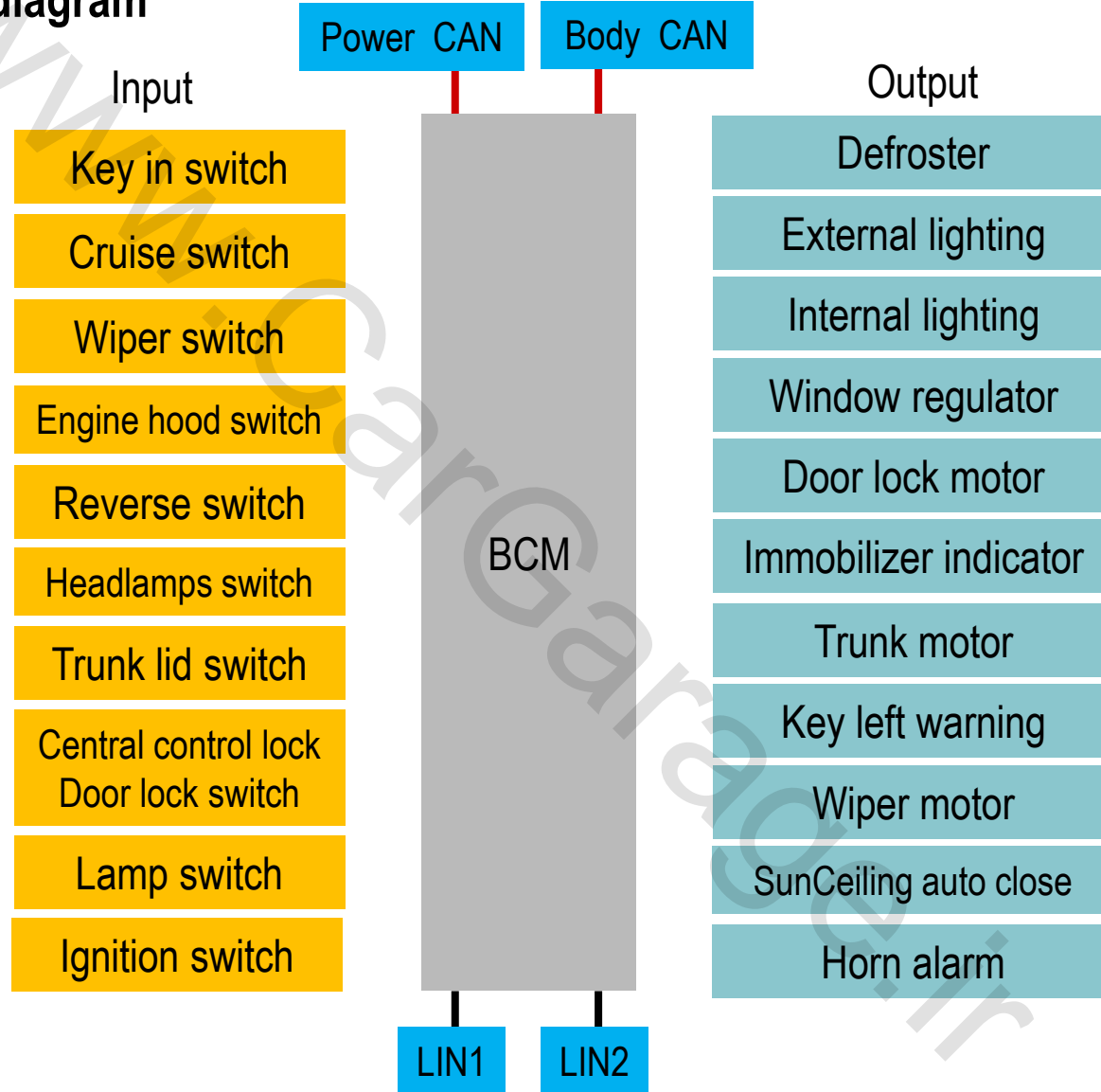

3. Function description

| No. | Function | Function description |
|-----|---|---|
| 1 | Rear defroster | <p>The working conditions of rear defroster are:</p> <p>①The key is turned to ON;</p> <p>②The rear defroster switch is activated.</p> <p>When rear defroster is working, rearview mirror and rear windshield will be heated. Press rear defroster switch again, rear defroster will be deactivated.</p> |
| | | <p>When rear defroster is working, turn IGN SW to OFF/ACC, rear defroster will be deactivated. Turn IGN SW to ON again, rear defroster will be no longer activated.</p> |
| 2 | Key left-in warning (for basic equipment) | <p>If key is not removed after it turns to OFF, key left-in warning will be activated when FL door opens (6 buzzes).</p> |
| | | <p>Open FL door, insert the key, and the key left-in warning will not be activated.</p> |
| | | <p>With the key at OFF, open the FL door, and the key left-in warning will not be activated. In this case, turn the key to ACC/ON and then to OFF, and the key left-in warning will be activated.</p> |

3. Function description

| | | |
|---|---|---|
| 3 | Turning lamp | <p>When key at ON, if left turn lamp switch is activated, left turn lamp will on.</p> <p>When key at ON, if right turn lamp switch is activated, right turn lamp will on.</p> |
| 4 | Hazard warning lamp | <p>When hazard warning lamp switch is activated, all turning lamps will be lit at the same time.</p> <p>Press hazard warning lamp switch and hazard warning lamp will be lit. Press the switch again, the lamps will be off.</p> <p>The hazard warning lamp is independent of the IGN SW status.</p> <p>If hazard warning lamp works, indicator lamp of hazard warning will be lit.</p> |
| 5 | Diagnosis of turning lamp and hazard warning lamp | <p>If one of turning lamp is damaged, turn on the turning lamp on this side, the turning lamps on this side and the corresponding indicator on instrument cluster will flash at double normal frequency. For the other side turning lamp works normal if it is no trouble.</p> <p>If one of turning lamp is damaged, active the hazard warning lamp, turning lamps and the indicator lamp of hazard warning on instrument cluster will flash at double normal frequency, the indicator lamp of hazard warning lamp switch will also flash at double normal frequency.</p> |

3. Function description

| | | |
|---|---|---|
| 6 | Emergency braking double-frequency flashing | When vehicle speed exceeds 55km/h, depress brake pedal in emergency, all turning lamps, indicator lamp of turning lamps on instrument cluster, indicator lamp of hazard warning lamp switch will flash at double normal frequency. |
| | | After emergency brake double-frequency flashing function is activated, this function will be deactivated in any following conditions: <ol style="list-style-type: none"> 1. Turn IGN SW to OFF/ACC; 2. Press hazard warning lamp again; 3. Depress accelerator pedal. |
| 7 | Parking lamp | The parking lamp can be turned on when IGN SW is in any mode. |
| | | Turn on parking lamp switch, and parking lamp will be lit. Turn off parking lamp switch, and parking lamp will be off. |
| 8 | Low beam lamp | With IGN SW at ON, turn headlamp switch to low beam position, the low beam lamp will be lit. |
| | | When headlamp multi-function switch is moved to any position other than low beam position, the low beam lamp will not be off. |
| | | Turn the key to ACC/OFF, and the low beam lamp will be off. |

3. Function description

| | | |
|---|----------------|---|
| 9 | Follow Me Home | <p>Working pre-conditions:</p> <ul style="list-style-type: none"> ① Within 2 minutes after the key is turned to OFF; ② The Flash switch is activated shortly. <p>Activation: Parking lamp and low beam lamp are lit by BCM, the indicator lamp on instrument cluster will be lit.</p> |
| | | <p>Within 2 minutes after the key is turned to OFF, each operate Flash switch, Follow Me Home will be activated for 30s, and this function can be activated for 8 times at most(240s).</p> |
| | | <p>When Follow Me Home is activated, if its working time reaches, it will off automatically.</p> |
| | | <p>When Follow Me Home is activated, long press Flash switch(>3s), low beam lamp and parking lamp will be off and the function will be quit.</p> |
| | | <p>When Follow Me Home is activated, turn IGN SW to ACC/ON, and Follow Me Home will stop.</p> |
| | | <p>With the key at OFF, within 2 minutes after Follow Me Home is activated, if the time still not exceed 2 minutes since turn off Follow Me Home function, Follow Me Home can be still activated.</p> |

3. Function description

| | | |
|----|----------------------------|--|
| 10 | High beam lamp | Working pre-conditions: ① Turn IGN SW to ON; ② Low beam lamp is on; ③ High beam lamp switch is turned on. |
| | | When high beam lamp is working, turn IGN SW to ACC/OFF, high beam lamp will off. |
| | | When high beam lamp is working, turn off high beam lamp switch, high beam lamp will off. |
| | | When high beam lamp is working, turn off low beam lamp switch, high beam lamp will off. |
| 11 | Overtake lamp (Flash lamp) | When Flash switch is activated in any key mode, high beam lamp will be lit. |
| | | Turn off Flash switch, the high beam lamp will off. |

3. Function description

| | | |
|----|----------------|---|
| 12 | Front fog lamp | <p>Working pre-conditions:</p> <ul style="list-style-type: none"> ① Turn the key to ON; ② The parking lamp is on; ③ Turn on front fog lamp switch. |
| | | <p>When front fog lamp is activated, turn off front fog lamp switch, front fog lamp will be off. Turn on the switch again, and the lamp will be lit.</p> |
| | | <p>When front fog lamp is activated, turn IGN SW to ACC/OFF, front fog lamp will be off. Turn the key to ON again, front fog lamp will be lit again.</p> |
| | | <p>When front fog lamp is activated, turn off parking lamp, front fog lamp will be off. Turn on parking lamp again, front fog lamp will be lit again.</p> |
| | | <p>When front fog lamp switch is on, the indicator lamp of front fog lamp will be lit.</p> |

3. Function description

| | | |
|----|--|---|
| 13 | Turn signal & fog lamp auxiliary lighting (The default value is no) | <p>For basic configuration vehicle, working pre-conditions are:</p> <ul style="list-style-type: none"> ①IGN SW is ON; ②Parking lamp and low beam lamp are lighting; ③Turning lamp on one side is activated. <p>If any above condition is not met, the front fog lamp will be off and this function will be deactivated automatically.</p> <hr/> <p>For comfort/luxury configuration vehicle, working pre-conditions are:</p> <ul style="list-style-type: none"> ①IGN SW is ON; ②Parking lamp and low beam lamp are lighting; ③The turning angle of steering wheel is larger than 45°, or one turning lamp is activated. <p>If any above condition is not met, the front fog lamp will be off and this function will be deactivated automatically.</p> |
|----|--|---|

3. Function description

| | | |
|----|---------------|--|
| 14 | Rear fog lamp | <p>1. Turn on rear fog lamp by low beam lamp</p> <p>Working pre-conditions are: ①IGN SW is ON; ②Parking lamp is on; ③Low beam lamp is lit.</p> |
| | | <p>When rear fog lamp is activated, turn IGN SW to ACC/OFF, rear fog lamp will be off. Turn the key to ON, rear fog lamp will not lit.</p> |
| | | <p>When rear fog lamp is activated, turn off low beam lamp, rear fog lamp will be off. Turn on parking lamp, rear fog lamp will not lit.</p> |
| | | <p>2. Turn on rear fog lamp by front fog lamp:</p> <p>Working pre-conditions are: ①IGN SW is ON; ②Parking lamp is on; ③Front fog lamp is lit.</p> |
| | | <p>When rear fog lamp is activated, turn IGN SW to ACC/OFF, rear fog lamp will be off. Turn the key to ON, the rear fog lamp will not be lit.</p> |
| | | <p>When rear fog lamp is activated, turn off front fog lamp, rear fog lamp will be off. Turn on front fog lamp, rear fog lamp will not be lit.</p> |
| | | <p>When rear fog lamp is activated, turn off front fog lamp, rear fog lamp will be off. Turn on front fog lamp, the rear fog lamp will not be lit.</p> |

3. Function description

| | | |
|----|----------------------|---|
| 15 | Battery power saving | <p>1. Turn IGN SW to OFF, open any door, the battery power saving function will be activated. In this case, if ceiling lamp switch is turned to door position, the ceiling lamp will remain lit, and it will be off after 15 minutes delay.</p> |
| | | <p>2. Turn IGN SW to OFF, open the trunk, the battery power saving function will be activated. In this case, trunk lamp will remain lit, and it will be off after 15 minutes delay.</p> |
| | | <p>3. Turn IGN SW to OFF, open the engine hood, the battery power saving function will be activated for 15 minutes. If any of door/engine hood/trunk lid is opened within 15 minutes, another 15min counting will be restarted.</p> |
| 16 | Trunk lamp | <p>If trunk lid is opened, the trunk lamp will be lit for 15 minutes at most .</p> |
| | | <p>When trunk lid is closed, the trunk lamp will be off.</p> |

3. Function description

| | | |
|----|--------------|---|
| 17 | Ceiling lamp | When ceiling lamp switch is turned to door position, the ceiling lamp control logic is as follows: |
| | | 1. Ceiling lamp control by door opening: |
| | | If any door is opened, ceiling lamp will be lit for 15 minutes. |
| | | If another door is opened within 15 minutes, another 15 min counting will be restarted. |
| | | If the previously opened door is closed within 15 minutes, ceiling lamp will remain lit for 15s and then it will be off 2s later. |
| | | 2. Ceiling lamp control by remote controller: |
| | | When all doors are closed, ceiling lamp will be off immediately after BCM receives locking door signal from remote controller. |
| | | When vehicle is in body anti-theft mode, after BCM receives unlocking signal from remote controller, ceiling lamp will lit for 15s and it will be off 2s later. |
| | | When ceiling lamp is lighting, if IGN SW is turned to ON, ceiling lamp will be off immediately . |

3. Function description

| | | |
|----|--------------------------------|---|
| 18 | Lock/unlock by central control | 1. Lock/unlock by remote controller |
| | | If: ① The key is turned to OFF ② Four doors are closed ③ BCM receives lock signal from remote controller, all doors will be locked, left/right turning lamps will flash once and the horn will beep once shortly. |
| | | If: ① Any door is not closed properly ② The key is turned to OFF ③ BCM receives lock signal from remote controller, all doors will lock one time and unlock one time with turning lamps flashing twice. |
| | | If: ① Four doors are closed properly ② The engine hood or trunk lid is not closed properly ③ The key is turned to OFF ④ BCM receives lock signal from remote controller, once BCM receives unlock signal from remote controller, the central control will unlock once with left/right turn signal lamps flashing twice. |
| | | 2. Lock/unlock by central control |
| | | If four doors are closed, press lock switch, the doors will be locked. |
| | | Press unlock switch of central control, the doors will be unlocked. |
| | | If any door is not closed properly, press lock switch, the doors will not be unlocked. |

3. Function description

| | | |
|----|--------------------------------|--|
| 18 | Lock/unlock by central control | 3. Automatic unlock |
| | | If the doors are locked, turn key to OFF, all doors will be automatically unlocked. |
| | | If the central control locks the car, pull the door inward handle of driver side once, and the central control will unlock the car; open it inward for the second time, and the door will be unlocked. |
| | | If the central control locks the car, pull the door inward handle of non-driver side once, the central control will not unlock (except the driver side); pull the door inward handle for the second time, the corresponding door will be unlocked. |
| 19 | Door lock protection | Continuously press lock/unlock button for 10 times, and the lock/unlock function will be deactivated for 30s to protect the lock motor. |

3. Function description

| | | |
|----|-------------------|---|
| 20 | Remote controller | 1. Lock button of remote controller |
| | | If: ①The key is at OFF ②Four doors, engine hood and trunk lid are closed ③BCM receives lock signal from remote controller, the doors will be locked, turning lamps will flash once, horn will beep once, and body anti-theft function is set succeed. |
| | | If: ①The key is at OFF ②The driver side door is closed, and any other door is not closed ③BCM receives lock signal from remote controller, the doors will be locked once, turning lamps will flash twice, horn will not beep, and body anti-theft function is set failed. |
| | | If: ①The key is at OFF ②The driver side door is not closed ③BCM receives lock signal from remote controller, the doors will be unlocked once after locked once, turning lamps will flash twice, horn will not beep, and body anti-theft function is set failed. |
| | | If the key is at OFF, engine hood/trunk lid is not closed, press lock button of remote controller, and the central control will lock the doors with turning lamps flash twice and horn silent. |

3. Function description

| | | |
|----|-------------------|--|
| 20 | Remote controller | 2. Unlock button of remote controller |
| | | Press unlock button of remote controller, central control will unlock the car with turning lamp flashing twice. |
| | | 3. Trunk lid open button of remote controller |
| | | Turn the key to OFF, close four doors/engine hood/trunk lid, long press trunk lid open button, the trunk lid will be opened. |
| | | 4. Window glass down function by long press unlock button of remote controller |
| | | When key at OFF and doors are closed, long press unlock button of remote controller, door glass will be lowered. Release the button, and the glass will stop lowering. |

3. Function description

| | | |
|----|-----------------------|--|
| 21 | Window glass regulate | When ignition switch ON, the glass can be regulated by window regulate switch. |
| | | <p><i>Manual mode:</i> Long press window glass regulate switch, the glass will move correspondingly; release the switch, the glass will stop moving immediately.</p> <p><i>Automatic mode:</i> Short press window glass regulate switch, the corresponding glass will lower automatically; press the switch again, the glass will stop moving.</p> |
| | | Within 2 minutes after the key is turned from ON to ACC/OFF, the window glass can be operated by the window glass regulate switch. |
| | | Within 2 minutes after the key is turned from ON to ACC/OFF, if any front door is opened, window glass regulate function will be immediately deactivated. |
| | | When window glass regulator motor is working, if the key is turned to START, window glass regulator motor will pause to work, and restore the regulating operation after the engine is started. |

3. Function description

| | | |
|----|--|---|
| 22 | Body anti-theft management (set succeed) | If: ①The key is at OFF ②Doors, engine hood and trunk lid are closed ③ BCM receives lock signal from remote controller, body anti-theft function is set successfully. Indicator lamp of body anti-theft flashes, turning lamp flashes once and alarm siren beeps once. |
| | Body anti-theft management (set failed) | If any door is not closed and BCM receives lock signal from remote controller, turning lamps will flashes twice, the door lock will be locked once and then be unlocked. |
| | | If: ①The key is at OFF ②The driver side door is closed while any other door is not closed ③BCM receives lock signal from remote controller, the door will be locked, with turning lamps flashing twice and the horn silent, the body anti-theft function is set failed. |
| | | If: ①The key is at OFF ②The driver side door is not closed ③BCM receives lock signal from remote controller, the door will be locked and then unlocked, with turning lamps flashing twice and the horn silent, the body anti-theft function is set failed. |
| | | When key is at OFF, engine hood/trunk lid is not closed, press the lock button of remote controller, the door lock cannot be locked with turning lamps flashing twice and horn silent. |

3. Function description

| | | |
|----|--|--|
| 22 | Body anti-theft management (release succeed) | When BCM receives unlock signal from remote controller, body anti-theft function will be released with turning lamps flashing twice. |
| | | When the vehicle is in body anti-theft mode, turn the key to ON and then start the engine, the vehicle will be released from body anti-theft mode. |
| 23 | Body anti-theft management (trunk lid open mode) | When the vehicle is in body anti-theft mode, long press trunk lid open button of remote controller, the trunk lid will be opened with turning lamps flashing twice and horn silent. |
| | Body anti-theft management (alarm warning mode) | When the vehicle is in body anti-theft mode, alarm warning will work in any following cases: ①Engine hood is illegally opened ②Trunk lid is illegally opened ③Any door is illegally opened, alarm warning mode will be triggered with alarm siren beeps and turning lamps flashing, the warning will last for one work period. |
| | | While in alarm warning mode, if the opened door/engine hood/trunk lid is closed, the alarm siren will cease beeping after the current period is finished, with only indicator lamp of body anti-theft flashing quickly. |
| | | After the warning period is ended, LED will keep flashing quickly, and the door lock will not be locked automatically . |

3. Function description

| | | |
|----|--|---|
| 23 | Body anti-theft management (alarm release) | When the car is in the warning mode, if BCM receives lock signal from remote controller, the warning mode will be cancelled with the audible and visible warnings stopped. |
| | Body anti-theft management (body anti-theft reset) | Remove the key, close doors, engine hood and trunk lid, and the vehicle is set in body anti-theft mode. Press unlock button of remote controller, if no further operation (such as open the door, trunk lid or engine hood), doors will be locked after a certain period of time, and the body anti-theft function will be set again with four doors lock again, turning lamps flashing once and the horn beeping once. |
| 24 | Trunk lid open mode | Long press trunk lid open button of remote controller, trunk lid will open. |
| | | When the car is unlocked by central control, the trunk lid can be opened by trunk external opening switch. |
| | | For basic configuration vehicle, when vehicle is in body anti-theft mode, the trunk external opening switch cannot be activated. |
| | | For luxury configuration vehicle, when vehicle is in body anti-theft mode, the trunk external opening switch can be activated and trunk lid can be opened when legal key approaches trunk lid switch. |

3. Function description

| | | |
|----|-------------|--|
| 25 | Door status | When any four doors, engine hood or trunk lid is opened, the corresponding indicator lamp on LCD screen of instrument cluster will display. |
| 26 | Wiper | The wiper has five positions: MIST, INT, HI, LO and OFF. |
| | | When the key at ON, turn wiper switch to LO or MIST, the wiper will work at low speed. |
| | | When the key at ON, turn wiper switch to HI, the wiper will work at high speed. |
| | | INT position: for the vehicle not equipped with rain sensor, turn wiper switch to AUTO position, the wiper will work intermittently. Note: There are four INT positions, with the time interval of 2/4/8/13s. |

3. Function description

| | | |
|----|--------------|---|
| 27 | Wiper washer | Turn on washer switch, the washer motor will start working until the washer switch is released. |
| | | With the key at ON, short pull the washer switch, the wiper will work at low speed. After the wiper works 2 cycles, it will return to original position. |
| | | With the key at ON, long pull the washer switch($\geq 1s$), and then release the switch, the wiper will work at low speed, and the wiper will work for at least 3 cycles before it returns to original position. |
| | | With the key at ON, turn the wiper switch to LO position, the wiper will work at low speed; if the key is turned to ACC/OFF, the wiper will return to original position automatically after the working cycle is finished. |
| | | With the key at ON, turn the wiper switch to HI position, and the wiper will work at high speed; if the key is turned to ACC/OFF, the wiper will return to original position automatically after the working cycle is finished. |
| 28 | Cruise | Operate the cruise switch, and BCM will send relevant signals (refer to signals). |

5

Window & anti-pinch sunroof system

1. General description
2. Operation of window regulator system
3. Circuit diagram analysis

5. Window & anti-pinch sunroof system

www.CarGarage.ir

1. General description of window lifter system (without anti-pinch function)

Components:

- Driver side switch
- Passenger side switch
- Remote controller
- 4 window lifter motor
- BCM

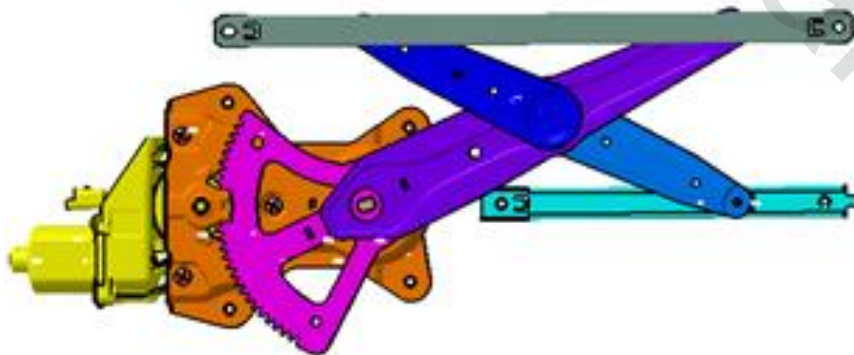

www.CarGarage.ir

2. Operation of window regulator system (without anti-pinch function)

Function description:

① When IGN SW at ON, or within 2 minutes after IGN SW is turned from ON to OFF/ACC:

② Operate window lifter switch

Manual mode: Long press window lifter switch, the glass acting; release it, the glass stop lifting.

Automatic mode: Short press window lifter switch, the glass will lower automatically; press the switch again, the glass will stop. If any front door is opened within 2 minutes after the key is turned to ACC/OFF, the window lifter will be deactivated. If all doors are closed within the 2 minutes, the lifter will be no longer activated.

When the window lifter motor is working, if the key is turned to START, the motor will stop working immediately. After the engine is started, the glass will remain stopped.

Function of window glass down by long pressing:

① With IGN SW-OFF and all four doors close, long press unlock button on remote controller ($t \geq 1.5s$), and the glass of all four doors will be lowered. After the glass is lowered to the lowest position or the button is released during the glass lowering process, the glass will be immediately stopped (for CVT comfort/luxury configuration).

② With IGN SW-OFF and all four doors close, long press unlock button on remote controller ($t \geq 1.5s$), and the glass of all four doors will be lowered. After the glass is lowered to the lowest position or the button is released during the glass lowering process, the glass will be immediately stopped (for MT standard/comfort configuration).

5. Window & anti-pinch sunroof system

2. Operation of window regulator system (without anti-pinch function)

Description of fault protection function

The window lifter motor is controlled by relay in BCM:

When BCM detects upper/lower limit position of the glass, BCM will stop driving window lifter motor (the stalling time is 400ms±50ms).

After 8s of BCM receives glass lifting signal, if the glass is not raised or lowered to its limit position, the lifter motor will stop working.

Where a certain external resistance is detected, BCM will stop the relay working to protect the circuit and avoid any pinch.

| DTC designation | DTC parameter | | | Description | Fault type |
|-----------------|---------------|--------|-----|----------------------|---------------------|
| | HIGH | MIDDLE | LOW | | |
| B100C-13 | 90 | 0C | 13 | FL window glass up | Output open circuit |
| B100C-71 | 90 | 0C | 71 | | Relay seized |
| B100D-13 | 90 | 0D | 13 | FL window glass down | Output open circuit |
| B100D-71 | 90 | 0D | 71 | | |
| B100E-13 | 90 | 0E | 13 | FR window glass up | Output open circuit |
| B100E-71 | 90 | 0E | 71 | | Relay seized |
| B100F-13 | 90 | 0F | 13 | FR window glass down | Output open circuit |
| B100F-71 | 90 | 0F | 71 | | Relay seized |
| B1010-13 | 90 | 10 | 13 | RL window glass up | Output open circuit |
| B1010-71 | 90 | 10 | 71 | | Relay seized |
| B1011-13 | 90 | 11 | 13 | RL window glass down | Output open circuit |
| B1011-71 | 90 | 11 | 71 | | Relay seized |
| B1012-13 | 90 | 12 | 13 | RR window glass up | Output open circuit |
| B1012-71 | 90 | 12 | 71 | | Relay seized |
| B1013-13 | 90 | 13 | 13 | RR window glass down | Output open circuit |
| B1013-71 | 90 | 13 | 71 | | Relay seized |

5. Window & anti-pinch sunroof system

3. Circuit diagram analysis (without anti-pinch function)

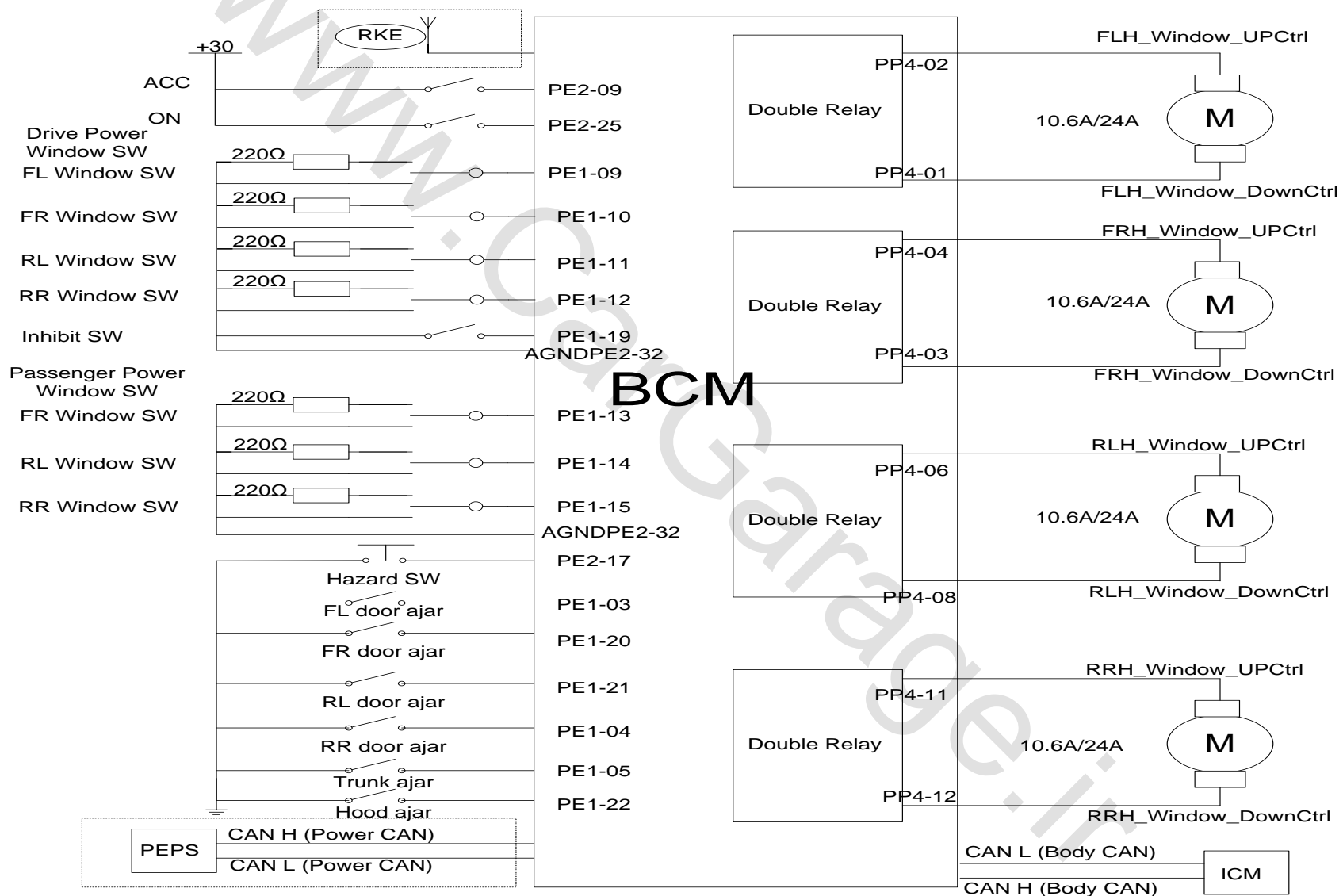

5. Window & anti-pinch sunroof system

www.CarGarage.ir



1. General description of window lifter system (with anti-pinch function)

Components:

- Driver side switch
- Passenger side switch
- Remote controller
- 4 window lifter motor
- BCM
- Anti-pinch module

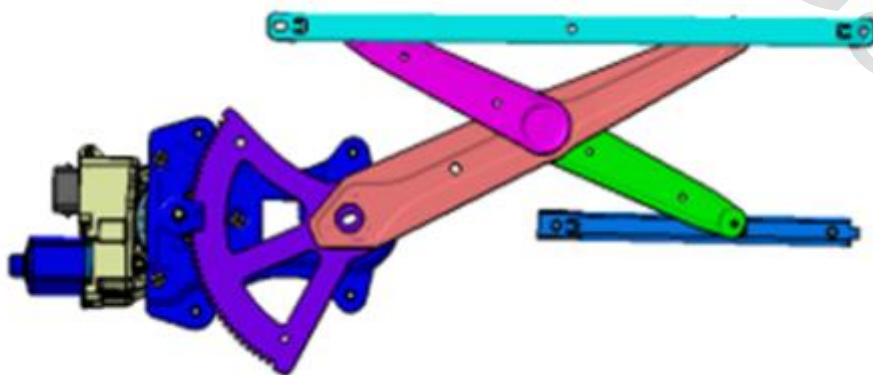

www.CarGarage.ir

5. Window & anti-pinch sunroof system

2. Operation of window regulator system (with anti-pinch function)

Function description of anti-pinch inhibition :

The anti-pinch inhibition function is a characteristic function of anti-pinch module.

When the glass encounters any obstruction during raising, if the glass can't reach its extreme position all the time, in such a case, the anti-pinch function will be deactivated and the anti-pinch inhibition function will be activated.

Description on anti-pinch inhibition process

Within 10s since the first time motor anti-pinch reverse rotate during the glass raising process, if the second time motor reverse rotate occurs within that 10s, the automatic lifting function will be disabled; if the glass remains rising within that 10s, the motor reverse rotate will no longer occur when the glass encounters any obstruction, and the anti-pinch function will be disabled, with the system entering the non-initialization mode.

After the anti-pinch inhibition function is activated, the glass can be raised manually with the anti-pinch function deactivated; in this case, the motor will break through the fault point at the maximum torque to close the window.

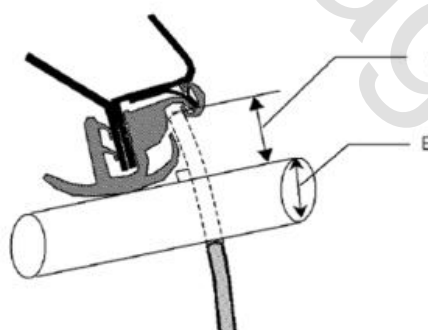
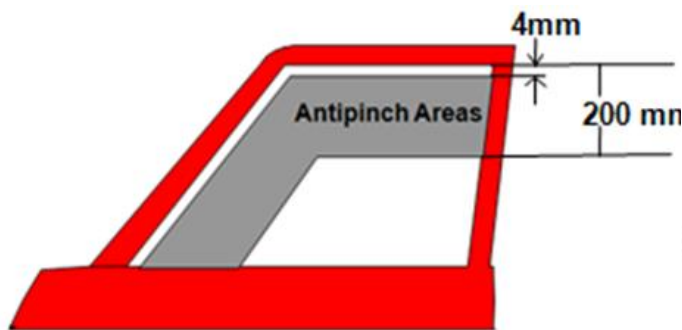

A: Distance from glass upper stalling position to window wool groove lower edge
B: Distance from glass to wool groove lower edge; effective area of anti-pinch : 4mm-200mm;

2. Operation of window regulator system (with anti-pinch function)

Description of window lifter (with anti-pinch function):

For the window lifter with anti-pinch function, the FL door non-local switch is connected to BCM receiving terminal, and each local switch is connected to the corresponding anti-pinch control module. The motor is directly driven by anti-pinch control module, and LIN communication is provided between BCM and anti-pinch module.

① When the key is located at ON, or within 2 minutes after the key is turned from ON to ACC/OFF:

② Operate the window lifter switch

Manual mode: Long press the window lifter switch, and the glass will act; release the switch, and the glass will stop lifting.

Automatic mode: Short press the window lifter switch, and the corresponding glass will lower automatically; press the switch again, and the glass will be stopped.

If any front door is opened within 2 minutes after the key is turned to ACC or OFF, the window lifter will be deactivated. If all doors are closed within the two minutes, the lifter will be no longer activated.

When the window lifter motor is working, if the key is turned to START, the motor will stop working immediately. After the engine is started, the glass will remain stopped.

2. Operation of window regulator system (with anti-pinch function)

Description of window lifter (with anti-pinch function):

The function of window up/down by long pressing:

① At IGN-OFF, with all four doors closed, long press unlock button on PEPS remote controller ($t \geq 1.5s$), and the glass of all four doors will be lowered. After the glass is lowered to the lowest position or the button is released during the glass lowering process, the glass will be immediately stopped.

② At IGN-OFF, with all four doors closed, long press lock button on PEPS remote controller ($t \geq 1.5s$), and the glass of all four doors will be raised. After the glass is raised to the highest position or the button is released during the glass raising process, the glass will be immediately stopped.

Ignition signal:

1. When glass is acting, BCM receives ignition signal, the glass will immediately stop lifting;
2. In the case of automatic lifting window glass, during ignition process, the glass will stop lifting; after the ignition, the glass will continue the previous lifting operation;
3. In the case of manual lifting window glass, during ignition process, the glass will stop lifting; after the ignition, if the input switch remains closed, the glass will continue the previous manual lifting operation;
4. During ignition process, the window lifter input signal will become invalid;
5. The motor reversing under anti-pinch function is independent of ignition.

2. Operation of window regulator system (with anti-pinch function)

Emergency mode:

The emergency mode will be activated in following two cases:

- 1.If the duration of loss of LIN communication is over 150ms after the anti-pinch module is electrified and the LIN communication is not recovered after 150ms, the window lifter motor will enter the emergency mode;
2. During the normal communication of LIN, communication timeout happens, if the enable signal WL _ Authorization=1 or the key is at ON before the communication timeout, the window lifter motor will enter the emergency mode.

The emergency mode is defined as follows:

- The duration of emergency mode is 10 minutes;
- If LIN communication is recovered within 10 minutes, the motor will exit the emergency mode and directly enter the normal mode;
- After 10 minutes, the lifter motor will immediate stop working and enter sleep mode;
- In the emergency mode, only the manual lifting function is enabled, while the automatic lifting is disabled.

2. Operation of window regulator system

LIN child lock signal:

The window lifter motor can get child lock switch status from the signal sent by BCM. When lifter motor doesn't receive child lock switch status, the motor will deem child lock not closed.

The child lock switch can interrupt the input of local window lifter switch on the passenger side.

When the child lock is activated, the passenger side window lifter motor will not receive input signal corresponding to the local switch.

If the driver side is the left side, FR door and rear doors are on passenger side;

If the driver side is the right side, FL door and rear doors are on passenger side;

When the passenger side glass is working, activate the child lock, and the glass will immediately stop.

Description of fault protection function (with anti-pinch function):

The window lifter motor is controlled by the relay in the motor anti-pinch module:

When the anti-pinch module detects upper or lower limit position of the glass, the anti-pinch module will stop driving the lifter motor (the stalling time is $400\text{ms} \pm 50\text{ms}$).

20s after the receipt of glass lifting signal, if the glass is not raised or lowered to its limit position, the motor will stop working.

The anti-pinch force is less than 100N. As for the specific control strategy, refer to instructions on anti-pinch function.

5. Window & anti-pinch sunroof system

www.CarGarage.ir



2. Operation of window regulator system

Fault code strategy (with anti-pinch function)

| DTC | DTC parameter | | | Description | Fault type |
|----------|---------------|--------|-----|---|--|
| | HIGH | MIDDLE | LOW | | |
| B1028-09 | 90 | 28 | 09 | FL anti-pinch module | Element fault |
| B1029-09 | 90 | 29 | 09 | FL door local switch seized | Element fault |
| B102A-09 | 90 | 2A | 09 | FL window lifter motor | Element fault |
| B102B-16 | 90 | 2B | 16 | FL window lifter motor voltage | Low voltage |
| B102B-17 | 90 | 2B | 17 | | High voltage |
| B102C-98 | 90 | 2C | 98 | FL window lifter motor temperature protection | Element or system temperature too high |
| B102D-09 | 90 | 2D | 09 | FR anti-pinch module | Element fault |
| B102E-09 | 90 | 2E | 09 | FR door local switch seized | Element fault |
| B102F-09 | 90 | 2F | 09 | FR window lifter motor | Element fault |
| B1030-16 | 90 | 30 | 16 | FR window lifter motor voltage | Low voltage |
| B1030-17 | 90 | 30 | 17 | | High voltage |
| B1031-98 | 90 | 31 | 98 | FR window lifter motor temperature protection | Element or system temperature too high |
| B1032-09 | 90 | 32 | 09 | RL anti-pinch module | Element fault |
| B1033-09 | 90 | 33 | 09 | RL door local switch seized | Element fault |
| B1034-09 | 90 | 34 | 09 | RL window lifter motor | Element fault |
| B1035-16 | 90 | 35 | 16 | RL window lifter motor voltage | Low voltage |
| B1035-17 | 90 | 35 | 17 | | High voltage |
| B1036-98 | 90 | 36 | 98 | RL window lifter motor temperature protection | Element or system temperature too high |
| B1037-09 | 90 | 37 | 09 | RR anti-pinch module | Element fault |
| B1038-09 | 90 | 38 | 09 | RR door local switch seized | Element fault |
| B1039-09 | 90 | 39 | 09 | RR window lifter motor | Element fault |
| B103A-16 | 90 | 3A | 16 | RR window lifter motor voltage | Low voltage |
| B103A-17 | 90 | 3A | 17 | | High voltage |
| B103B-98 | 90 | 3B | 98 | RR window lifter motor temperature protection | Element or system temperature too high |

www.CarGarage.ir

5. Window & anti-pinch sunroof system

2. Operation of window regulator system

Information of connectors and definitions of pins:

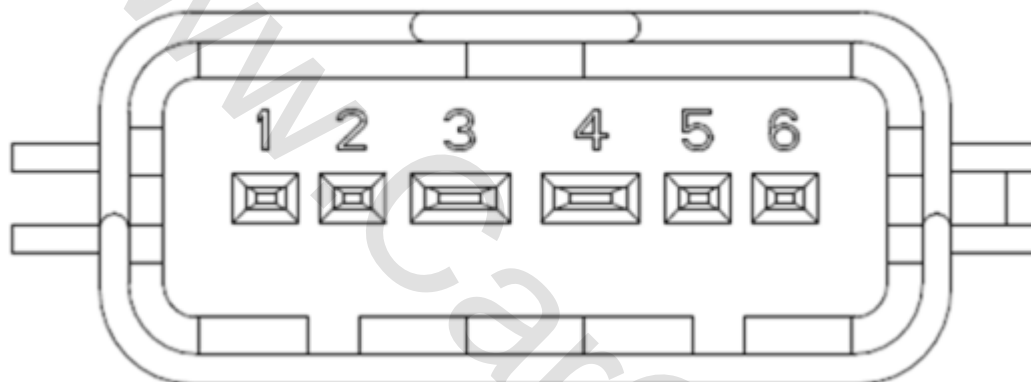

| Connector & Pin | Terminal Identification | Contact Design (mm) | I/O | Values |
|-----------------|-------------------------|---------------------|-----|--------------------------------|
| J1:1 | Local Switch | 1,5 | I | 0Ω = Down 220Ω = Up |
| J1:2 | Switch Ground | 1,5 | I | - |
| J1:3 | KL30 – VBat | 2,8 | P | Load supply |
| J1:4 | KL31 – GND | 2,8 | P | Load supply Ground |
| J1:5 | LIN | 1,5 | I/O | According to LIN specification |
| J1:6 | - | 1,5 | - | - |

5. Window & anti-pinch sunroof system

3. Circuit diagram analysis

Circuit diagram of window lifter system (with anti-pinch function):

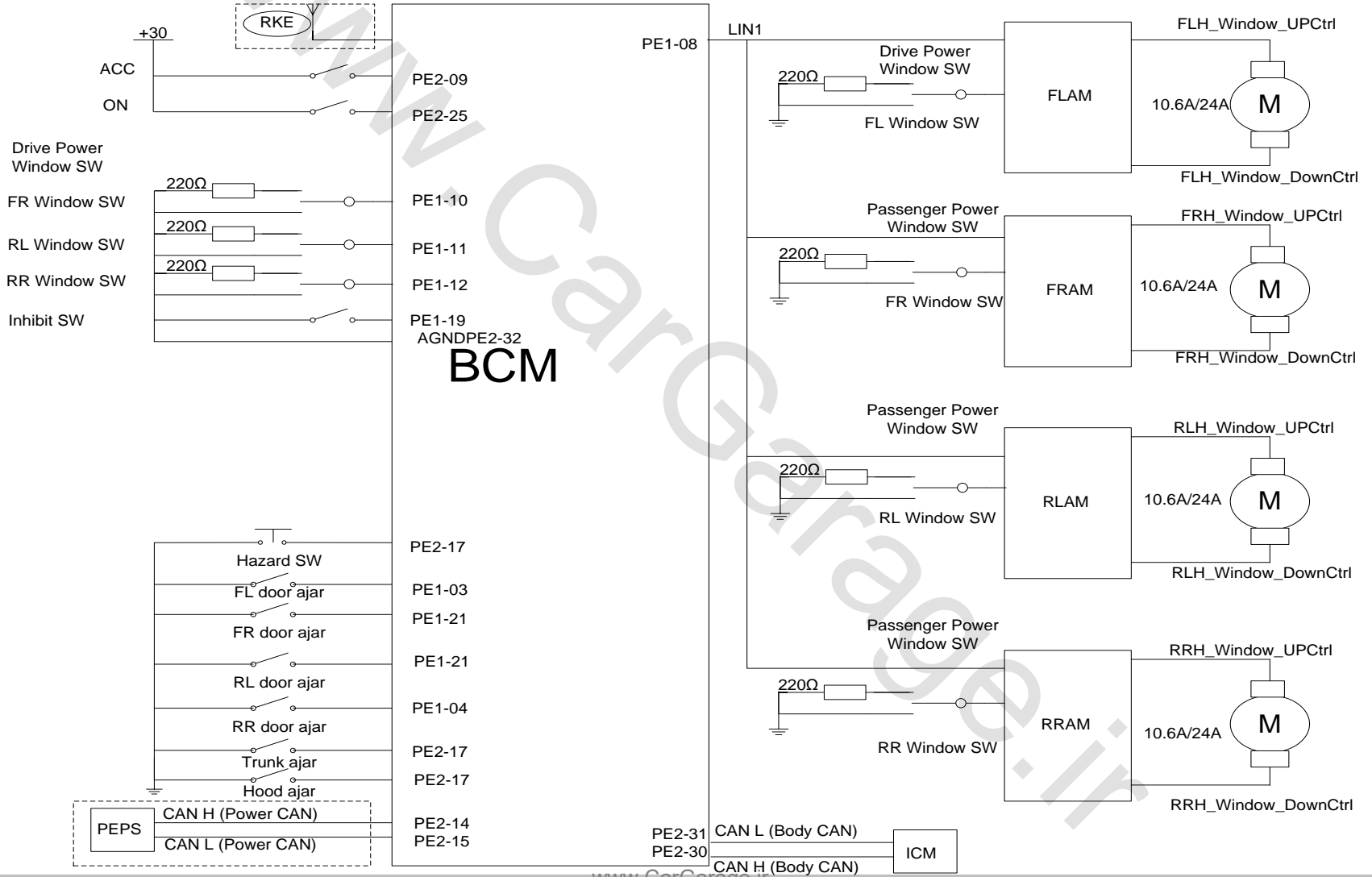

6

Anti-theft alarm and locking system

1. General introduction
2. System elements introduction
3. Function description
4. Circuit diagram analysis

1. General introduction

Receiving function of remote controller

Receiving functions of remote controller: (for MT standard and MT comfort)

- The frequency of 433.92MHZ is adopted. The remote control locking function is valid with the key at OFF, and invalid with the key at other positions.
- The remote control unlocking function is valid with the key at any position. Each time the button is pressed, the remote controller will transmit a 3-frame signal.

Receiving lock/unlock signals of PEPS: (for CVT comfort, CVT luxury and MT luxury)

- PEPS (passive entry + passive start function) is equipped in CVT comfort and CVT luxury cars, and the receiving functions of the remote control are integrated on the PEPS module. BCM communicates with PEPS module by CAN to lock/unlock the car and set anti-theft mode.

1. General introduction

Control diagram of central control lock

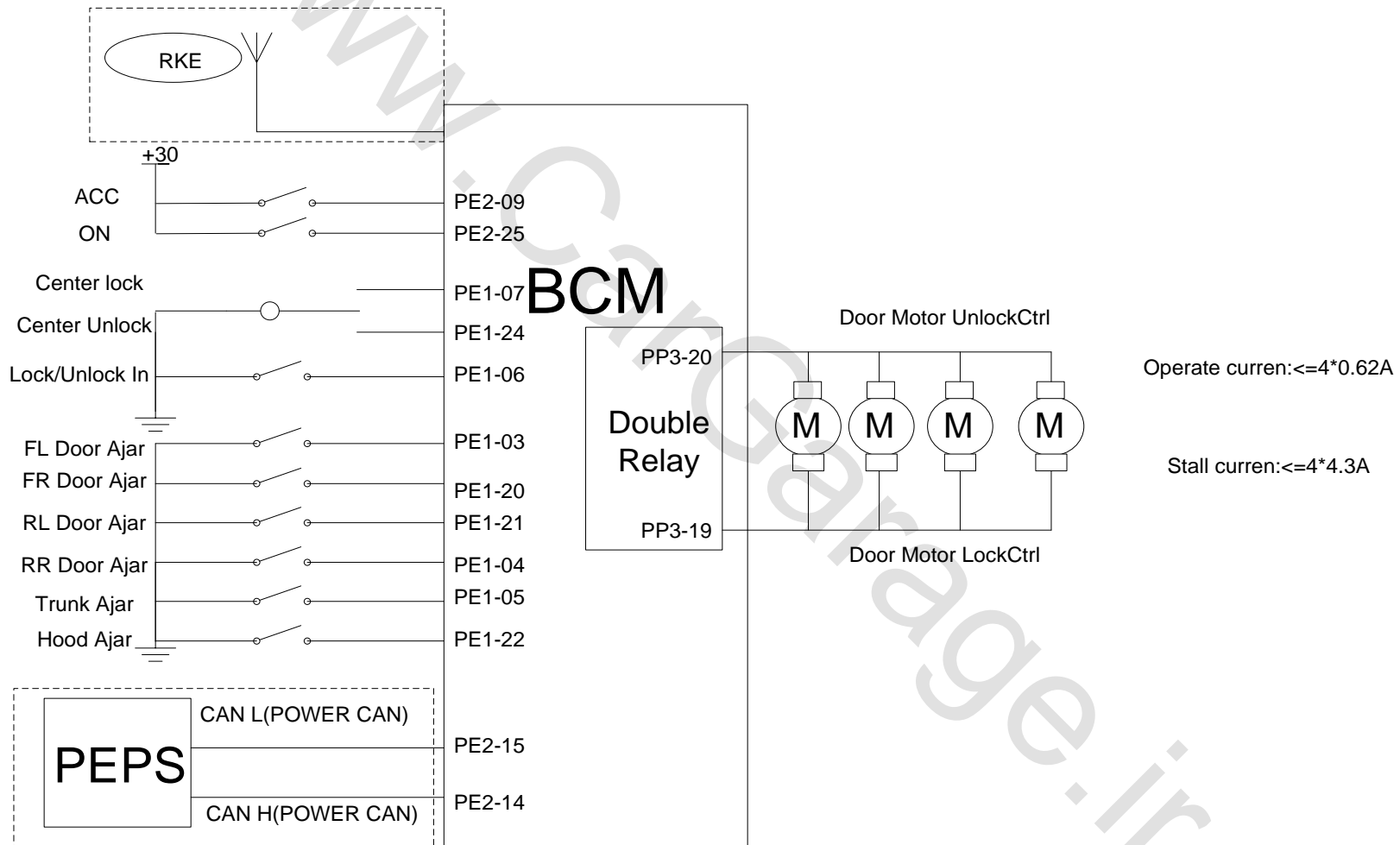

2. System elements introduction

Smart key

- Locking with the smart key;
- Mechanical unlock/lock door and operate ignition switch;
- Door unlock/lock and trunk lid open by remote control;
- Setting and relief of alarm;
- Engine anti-theft function;
- For replacement of the smart key, it is necessary to program PEPS/BCM by scanner;
- If the working distance of the smart key is shorten gradually, the battery should be replaced.



2. System elements introduction

Operation of remote controller

(1) Lock button on remote controller

If: ①The ignition key is at OFF ②Four doors, engine hood and trunk lid are closed ③The locking signal from the remote controller is received, the door will be locked, with the turn signal lamp flashing once and the horn giving a short sound, and the car is armed successfully.

If: ①The ignition key is at OFF ②The driver side door is closed, and any passenger side door is not closed ③The locking signal from the remote controller is received, the door will be locked and then unlocked, with the turn signal lamp flashing twice and the horn silent, and the car fails to be in anti-theft mode.

If: ①The key is at OFF ②The driver side door is not closed ③The locking signal from the remote controller is received, the door will be locked and then unlocked, with the turn signal lamp flashing twice and the horn silent, and the car fails to be in anti-theft mode.

With the key at OFF and engine hood/trunk lid not closed, press lock button on remote controller, doors will be locked, with the turn signal lamp flashing twice and the horn silent.

2. System elements introduction

Operation of remote controller

(2) Unlock button on remote controller

Press unlock button on remote controller, and the central control will unlock the car, with the turn signal lamp flashing twice.

(3) Trunk lid open button on remote controller

With the door locked, long press the trunk lid open button on the smart key (for about 2s), and within 30s, press the opening switch on trunk lid, trunk lid will be automatically opened, with the door lock status unchanged.

(4) Window glass down by long pressing

With the ignition key at OFF and all four doors, engine hood and trunk lid closed, long press the unlock button on remote controller, and glass of all four doors will be lowered. Release the button, and the glass will stop lowering.

2. System elements introduction

Central control door lock switch

- Non-latching type switch;
- Located on the driver side door trim panel, sharing the same switch assembly with the four door window lifter switch;
- This switch signal is in parallel connection with the driver door lock switch.



6. Anti-theft alarm and locking system

2. System elements introduction

Circuit diagram of central control door lock switch

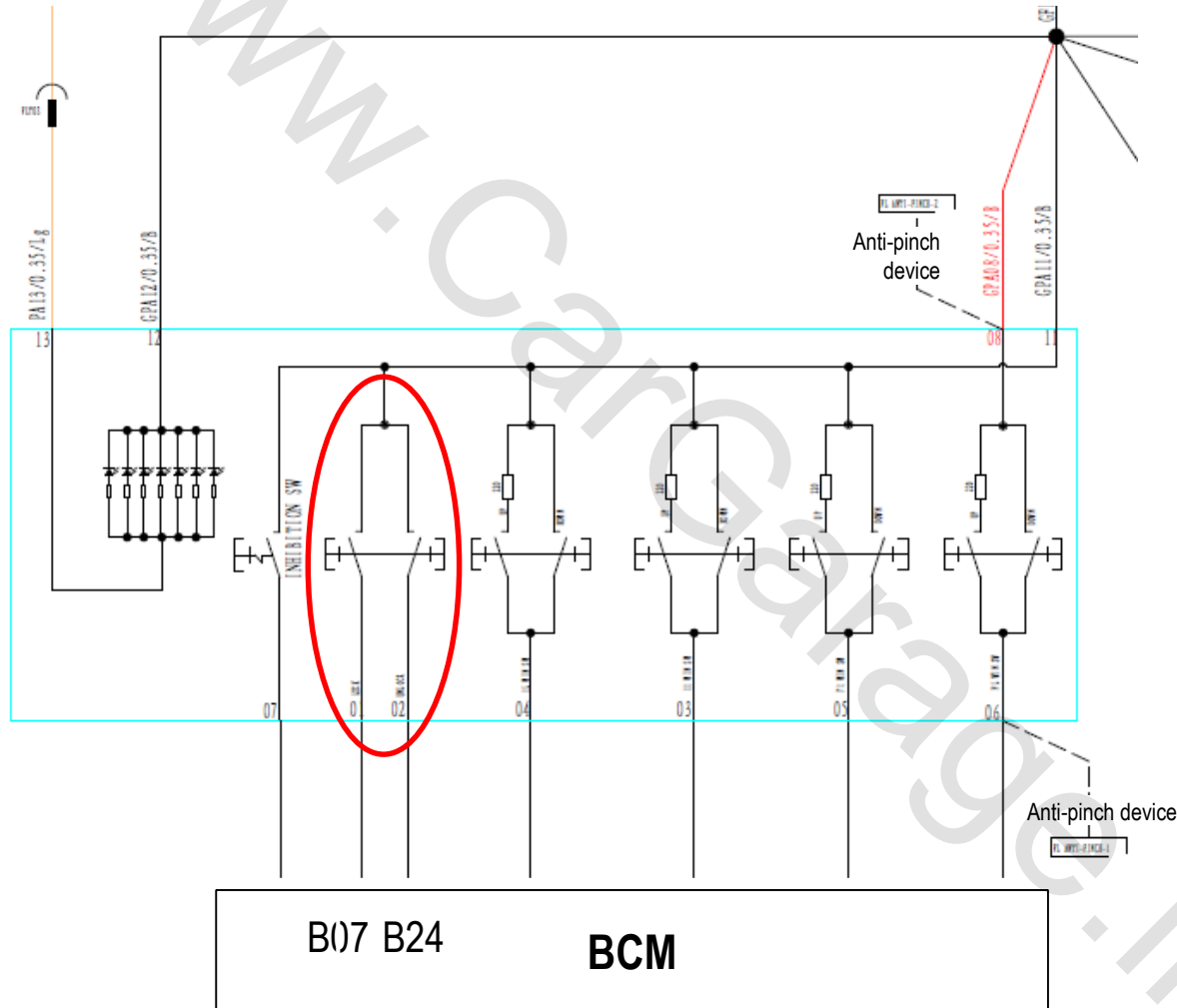

6. Anti-theft alarm and locking system

2. System elements introduction

Trunk lid open switch

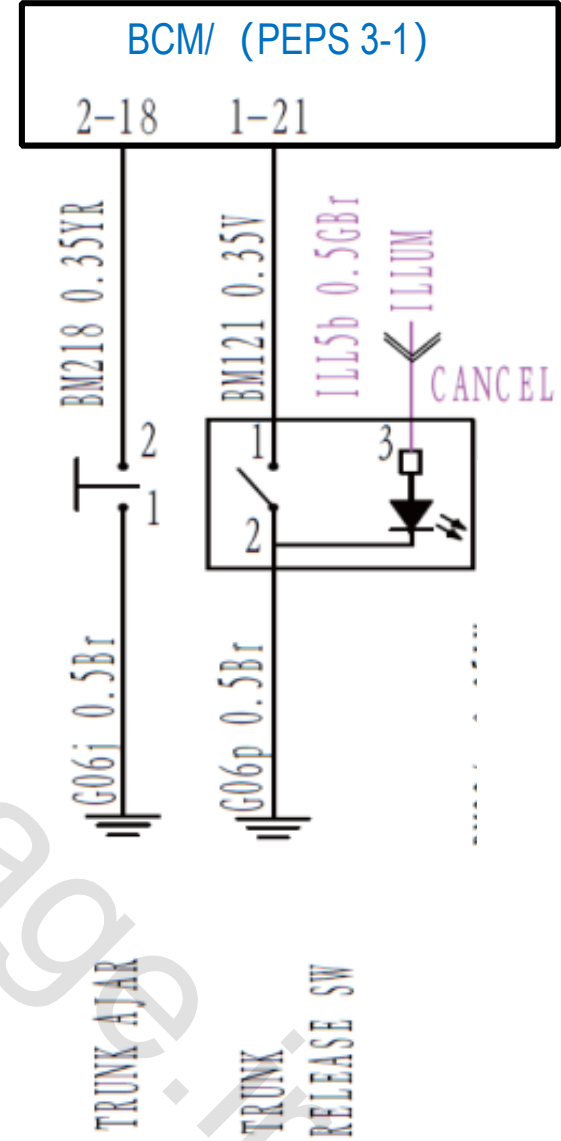
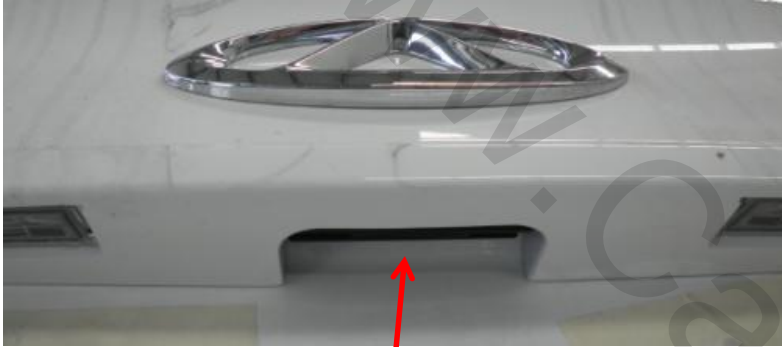

2. System elements introduction

Trunk lid contact switch and locking device

- Composed of trunk lock, escape handle and cable.
- Open by remote controller or trunk lid open switch.
- Pulling the escape handle inside can unlock the door.
- When trunk lid is opened, the switch will be closed.

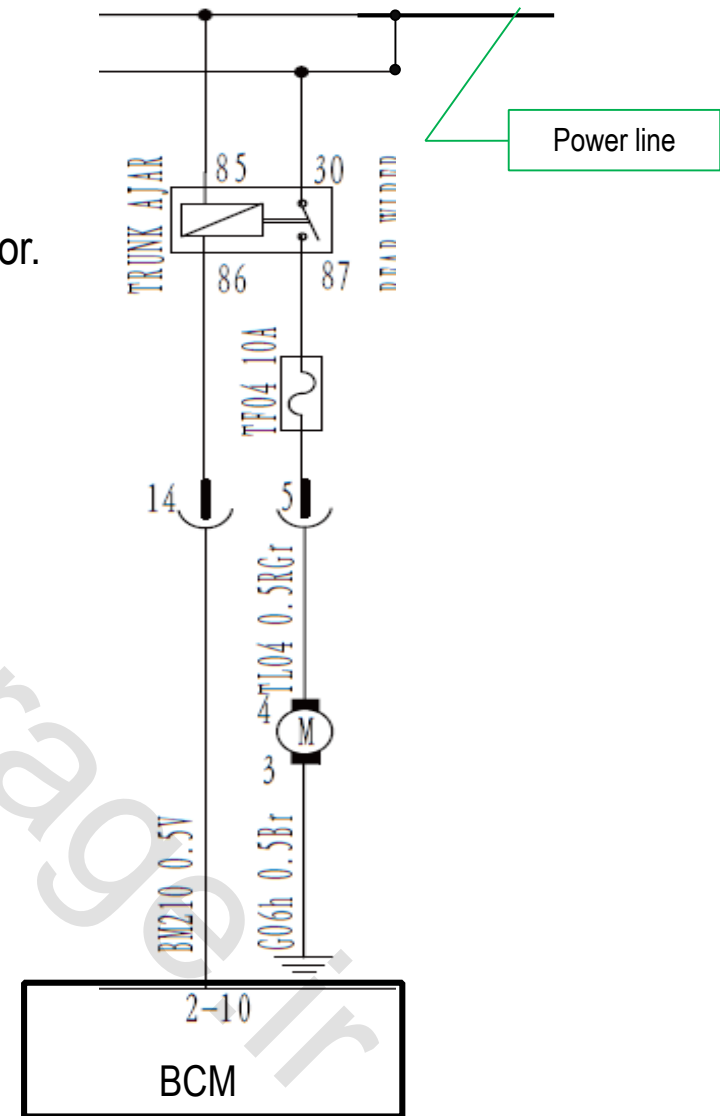

2. System elements introduction

Anti-theft indicator lamp

- Located on FL door
- Flashing slowly in alerting mode
- Quickly flashing in warning mode

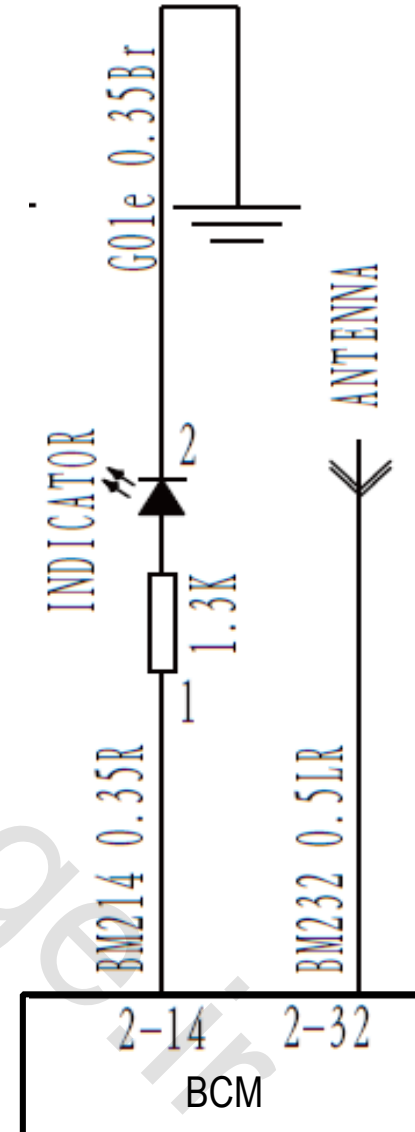

3. Function description

Driver side door lock assembly

- Built-in electric-mechanic integrated door lock
- Driver door with mechanical lock plug



3. Function description

Passenger side door lock assembly

- The passenger side door lock assembly is located on the corresponding door
- Built-in electric-mechanic integrated door lock
- The rear door lock is provided with child lock



3. Function description

Warning management of PEPS vehicle (CVT comfort/luxury, MT luxury):

Anti-theft protection function:

At IGN SW-OFF, with all doors, engine hood and trunk lid closed, press lock button on PEPS remote controller (BCM receives "order information=1(lock), information source=2(RKE)), and the door will be locked to arm the car (anti-theft indicator lamp will flash at the frequency of 0.5Hz at the duty ratio of 5% and the turn signal lamp will be lit once (500ms on), with alarm siren ringing for 50ms and the tweeter-woofer ringing for 20ms).

At IGN SW-OFF, with all doors, engine hood and trunk lid closed, operate the front door handle by PE (RKE of PEPS is within detection range of door handle antenna), and BCM will receive "order information=1(lock), Information Source=1(SMART)) to arm the car (anti-theft indicator lamp will flash at the frequency of 0.5Hz at the duty ratio of 5% and the turn signal lamp will be lit once (500ms on), with alarm siren ringing for 50ms and the tweeter-woofer ringing for 20ms).

3. Function description

Warning management of PEPS vehicle (CVT comfort/luxury, MT comfort/luxury):

Anti-theft failure mode:

At IGN SW-OFF, if any door is not closed, operate PKE or PE to lock door, and BCM will receive “order information=1(lock), Information Source=1(SMART) or 2(RKE)” and turn on the turn signal lamp for 500ms; 1.5s later, the turn signal lamp will be lit for another 500ms. The door will be locked and 500ms, unlocked, with the horn silent.

At IGN SW-OFF, if the engine hood or trunk lid is not closed, operate PKE or PE to lock it, and BCM will receive “order information=1(lock), Information Source=1(SMART) or 2(RKE)” and light the turn signal lamp for 500ms; 1.5s later, the turn signal lamp will be lit for another 500ms. The engine hood or trunk lid will be locked with the horn silent.

3. Function description

Warning management of vehicle without PEPS (MT standard):

Anti-theft protection function:

At IGN SW-OFF, with all doors, engine hood and trunk lid closed, if BCM receives locking order from RKE, the door will be locked to arm the car (anti-theft indicator lamp will flash at the frequency of 0.5Hz at the duty ratio of 5% and the turn signal lamp will be lit once (500ms on), with alarm siren ringing for 50ms and the tweeter-woofer ringing for 20ms).

Anti-theft failure mode:

At IGN SW-OFF, if any door is not closed and BCM receives locking order from RKE, BCM will light the turn signal lamp for 500ms; 1.5s later, the turn signal lamp will be lit for another 500ms. The door will be locked, and 500ms later, unlocked, with the horn silent.

At IGN SW-OFF, if the engine hood is not closed and BCM receives locking order from RKE, BCM will light the turn signal lamp for 500ms; 1.5s later, the turn signal lamp will be lit for another 500ms. The hood will be locked with the horn silent.

At IGN SW-OFF, if the trunk lid is not closed and BCM receives locking order from RKE, BCM will light the turn signal lamp for 500ms; 1.5s later, the turn signal lamp will be lit for another 500ms. The lid will be locked with the horn silent.

3. Function description

Anti-theft release protection function :

With the car in body anti-theft protection mode, if BCM receives unlocking signal from RKE, the car will be released from anti-theft protection mode; in this case, BCM will light the turn signal twice (at the frequency of 1Hz and duty ratio of 50%), anti-theft indicator lamp will be turned off.

The car can't be released from anti-theft protection mode by pressing lock button or trunk lid open button on remote controller, irrespective of the ignition key position.

With the car in body anti-theft protection mode(including the case in which the car is armed again after the alarm is triggered), if BCM receives the unlock order from RKE and no further operation (door opening, key rotation, opening of engine hood or trunk lid) continues, 30s later, BCM will arm the car again without any audible or visible indication.

Trunk lid open mode:

With the car armed, long press the trunk lid opening button the remote controller for more than 1.5s, and the turn signal lamp will be lit for 1s, with a 30s count during which if the trunk lid open button is pressed, BCM will open the trunk lid, with alarm siren silent. 30s later, the trunk lid can't be opened.

3. Function description

Warning mode:

When the car is armed by BCM, if any door or the engine hood or trunk lid is opened, BCM will enter the warning mode, with alarm siren 25s on and 5s off. The turn signal lamp will flash for 25s at 75 times per minute. In each cycle, the anti-theft indicator lamp will flash, 100ms on, 200ms off and 100ms on, at 1Hz. Altogether there are 3 warning cycles. The tweeter-woofer works at the frequency of 1Hz and duty ratio of 50%.

Release warning mode:

In warning mode, BCM receives the unlock signal from PEPS (including PEPS remote controller or door handle PE switch, BCM receives "order information=2(unlock)", "Information Source=1(SMART) or 2(RKE))", BCM will deactivate the audible and visible warning, but anti-theft indicator lamp will flash as in the alarm mode till IGN SW-ON.

3. Function description

External fault protection:

BCM directly drives the alarm siren. When alarm siren output terminal is shorted to GND, BCM driver chip will automatically enter protection mode, and stop high voltage output to avoid burning of wires.

Following fault code strategies are supported:

| DTC | DTC parameter | | | Description | Fault type |
|----------|---------------|--------|-----|--|-------------------------|
| | HIGH | MIDDLE | LOW | | |
| B101D-11 | 90 | 1D | 11 | Control circuit of alarm siren output terminal | Shorted to GND |
| B101D-12 | 90 | 1D | 12 | | Shorted to power supply |
| B101D-13 | 90 | 1D | 13 | | Output open circuit |

6. Anti-theft alarm and locking system

3. Function description

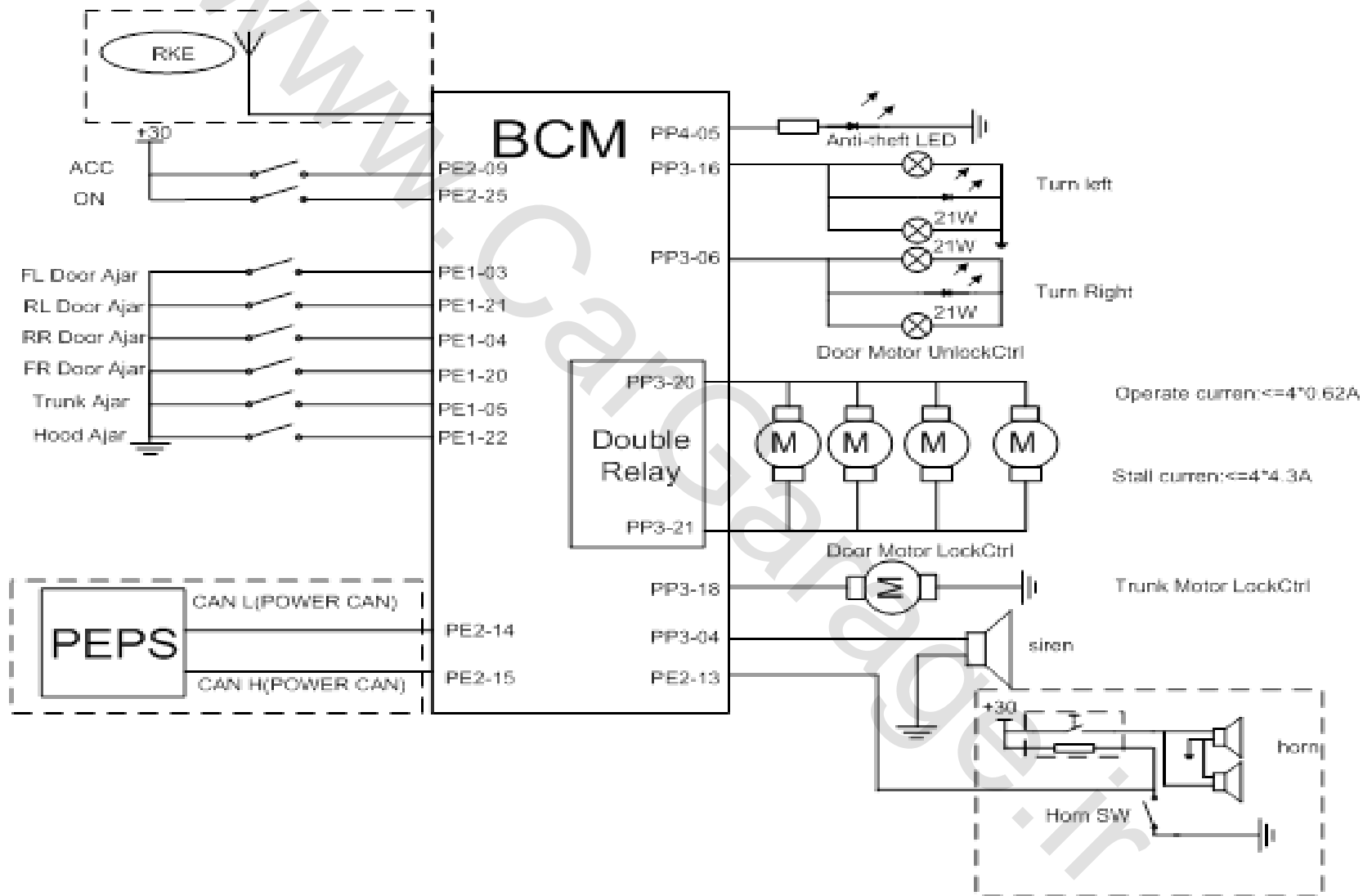

3. Function description

Trunk lid open function (for MT standard/comfort)

Hardware circuit of trunk lid open switch is connected in BCM which detects action of this switch.

With door lock status is open, press opening button on the trunk lid, and BCM will drive the motor to unlock the trunk lid (200ms). With door lock status is lock and the key at OFF, long press trunk lid open button on the remote controller for 1.5s above, there will be a 30s count during which if the trunk lid open button is pressed, BCM will drive the motor to unlock the trunk lid(200ms); 30s later, the trunk lid can't be opened.

With trunk lid open and trunk lamp lit, if the trunk lid is closed, the lamp will be off. If the lid remains open, the lamp will be off 15min later.

If one of following conditions is met, the 30s count of BCM will be ended:

- (1) When BCM receives lock order from remote control;
- (2) The 30s count is over;
- (3) BCM receives lock order from central control and mechanical lock;
- (4) Trunk lid is opened and then closed.

If the trunk motor acts for more than 4 times within 25s, BCM will disable the trunk opening for 30s.

3. Function description

Trunk lid open function (for CVT comfort/luxury, MT comfort/luxury)

Hardware circuit of trunk lid open switch is connected in BCM which detects action of this switch.

With door lock status is open, press opening button on the trunk lid, and BCM will receive the signal from PEPS "Trunk/back door external switch=10" to drive the trunk unlock motor working for 200ms.

With door lock status is lock, operate the trunk open button when trunk antenna identifies PEPE remote controller, and BCM will receive the signal "Information Source=1(SMART) and Order Information=4(TRUNK)" to drive the lock motor working for 200ms.

With the trunk locked and IGN SW-OFF, press trunk lid open button on remote controller of PEPS for more than 1.5s (BCM receives "Information Source=2(RKE)", "Order Information=4(trunk)" for more than 1.5s), and BCM will give a 30s count. In the counting time, if the trunk open button is operated (BCM receives "Trunk/backdoor external switch=10(unlock)"), BCM will drive the lock motor to unlock the trunk for 200ms. (At IGN-ON/IGN-ACC, the trunk lid can't be opened).

If the trunk motor is operated for more than 4 times within 25s, BCM will disable the trunk opening for 30s.

3. Function description

Trunk lid open function (for CVT comfort/luxury, MT comfort/luxury)

If one of following conditions is met, the 30s count of BCM will be ended:

- (1) When BCM receives lock order from PEPS (BCM receives Order Information=1(lock) by PEPS remote control or PE door handle);
- (2) The 30s count is over;
- (3) BCM receives lock order from central control and mechanical lock;
- (4) Trunk lid is opened and then closed.

If the trunk motor acts for more than 4 times within 25s, BCM will disable the trunk opening for 30s.

External fault protection function:

Trunk unlock motor is driven by BCM by its internal relay and is protected by internal fuse.

Following fault codes are supported:

| DTC | DTC parameter | | | Description | Fault type |
|----------|---------------|--------|-----|-----------------------|---------------|
| | HIGH | MIDDLE | LOW | | |
| B1024-71 | 90 | 24 | 71 | Trunk control circuit | Relay seizure |

6. Anti-theft alarm and locking system

3. Function description

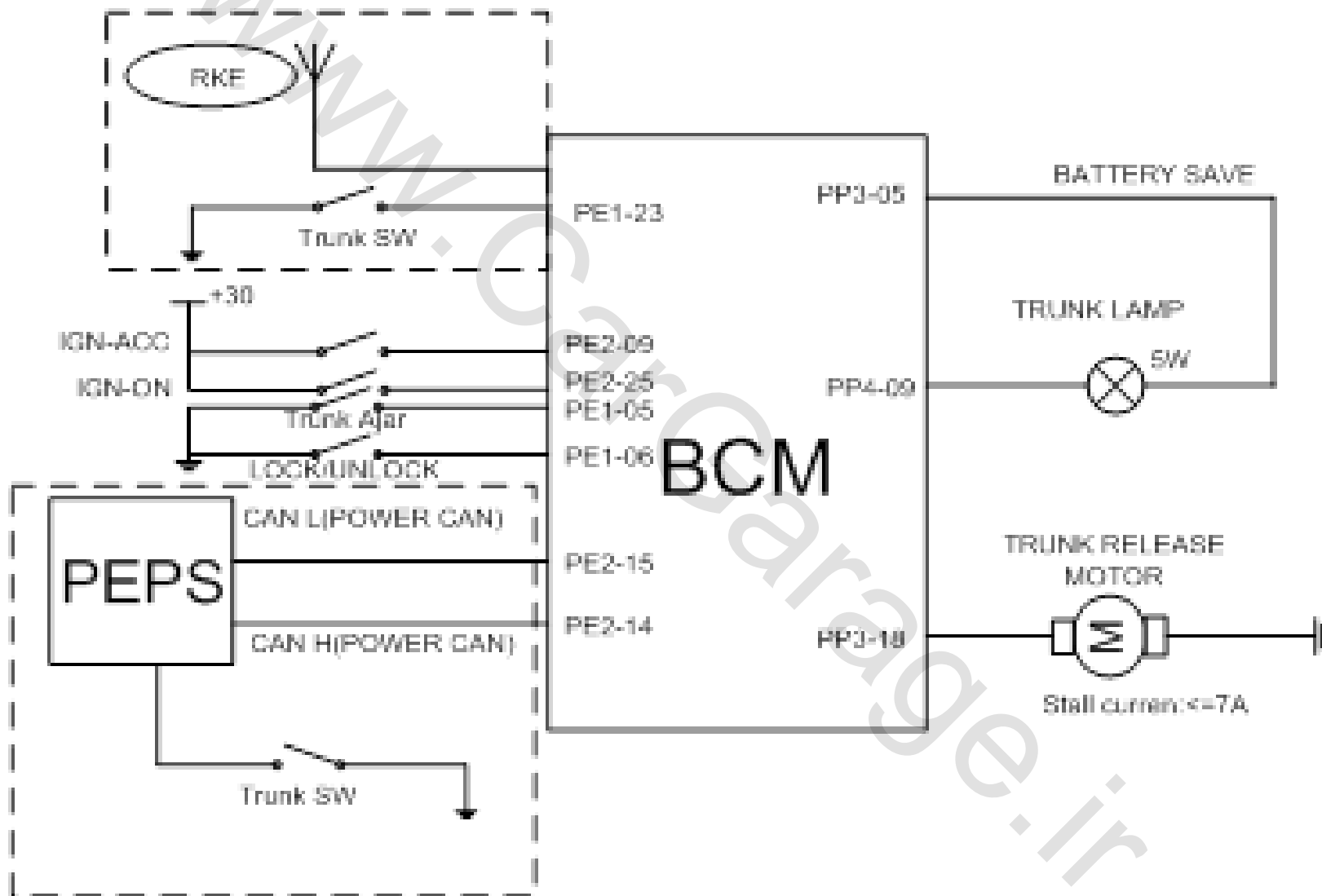

3. Function description

Door locking system (for vehicle without PEPS, MT standard/comfort):

(1) Door locking control by remote controller:

At IGN-OFF, with 4 doors closed, if BCM receives lock order from remote controller, BCM will lock the door; press the lock button again, and it will lock the door again. At IGN-ACC or ON, press the lock button on remote controller, and BCM will not work.

At IGN-OFF, if any door is opened, BCM will receive RKE lock signal and lock central control; 500ms later, the central control will be unlocked.

(2) Door lock control by central control switch

With 4 doors closed, if BCM receives central control lock order, BCM will lock doors. Press the lock button on the central control, and BCM will execute locking action.

If any door is open and BCM receives the central control lock order, four doors will not be locked. Press the unlock button on central control, and doors will be unlocked.

3. Function description

Door locking system (for vehicle without PEPS, MT standard/comfort):

(3) Central control unlocking by FL door inner handle:

With 4 doors locked (not armed), pull inner handle of FL door, central control will be unlocked.

(4) Automatic unlocking:

At 0 speed, with door locked, if ignition key is turned to OFF, BCM will unlock central control.

(5) Crash unlocking function:

With the key at ON, if BCM receives the signal "Crash Output Sts \neq 00", BCM will unlock the central control, and 1s later, unlock it again; in this condition, locking is disabled till the key is turned from ON to OFF.

3. Function description

Door locking system (for CVT comfort/luxury, MT comfort/luxury):

(1) Door lock control by PEPS remote control and PE smart entry:

At IGN-OFF, with 4 doors closed, operate lock button on PEPS remote controller or the front door handle. When BCM receives "order information=1(lock)", "Information Source=1(SMART) or 2(RKE)", it will lock doors. When operating RKE unlock button of PEPS again, BCM will lock doors again.

At IGN-OFF, when any door is opened, operate lock button on PEPS remote controller. When BCM receives "order information=1(lock)", "Information Source= 2(RKE)", it will lock central control, and 500ms later, unlock the control.

At IGN-OFF/ACC/ON, with 4 doors closed, operate lock button on PEPS remote controller or the front door handle. When BCM receives "order information=2(unlock)", "Information Source =1(SMART) or 2(RKE)", it will unlock doors. When operating unlock button of PEPS remote controller again, BCM will unlock doors again.

(2) Door lock control by central control switch:

With 4 doors closed, if BCM receives lock order from central control, BCM will lock doors; press the lock button on central control again, and BCM will lock doors.

If any door is opened, upon the receipt of central control lock order, BCM will not lock four doors; press unlock button on central control, and four doors will be unlocked.

3. Function description

External fault protection function:

The door lock motor is controlled by the relay in BCM. The motor output current is monitored by a detection circuit to provide effective protection in the case of over-current.

The motor output terminal is protected against over-current using fuses.

4. Circuit diagram analysis

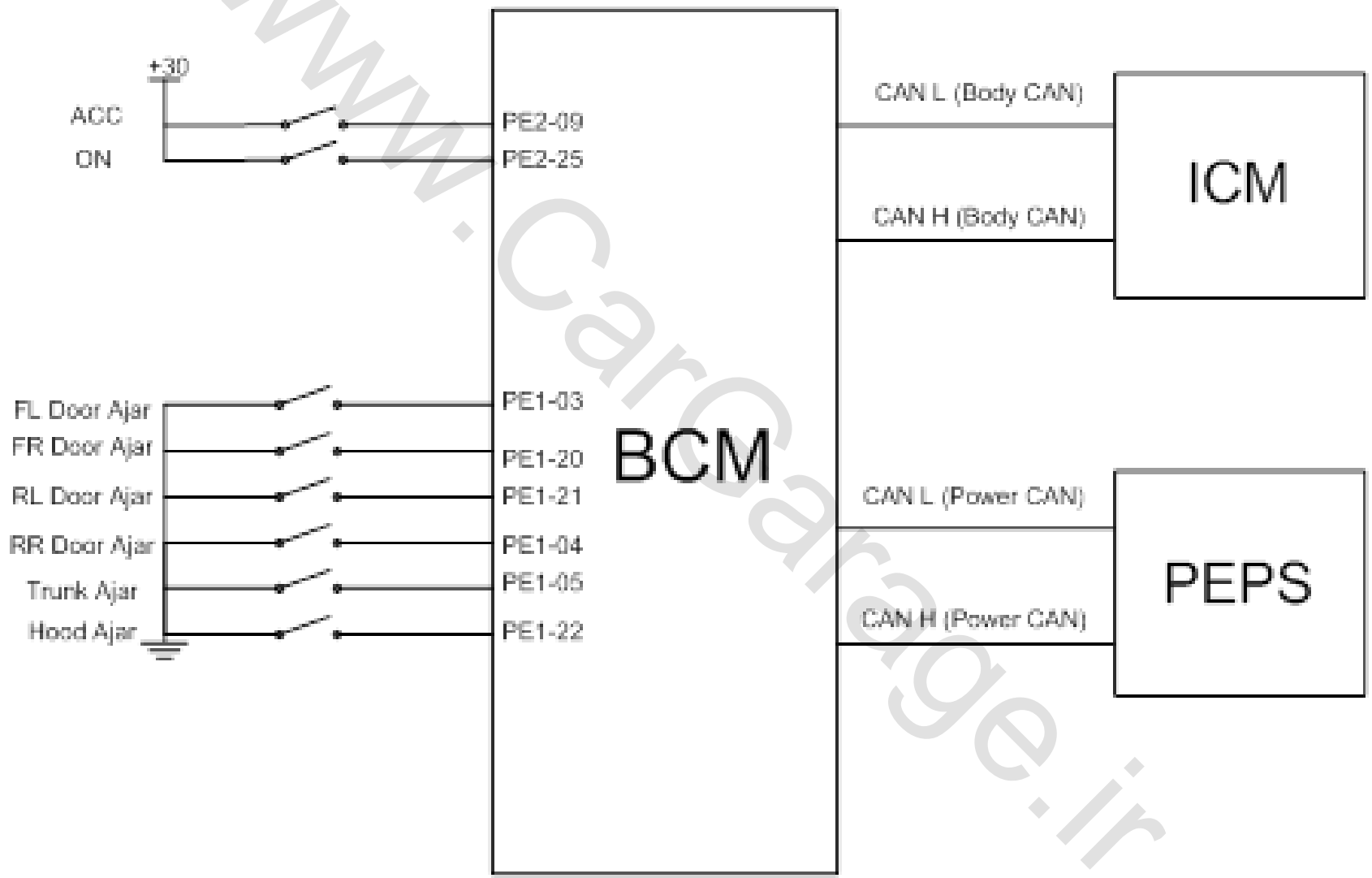

4. Circuit diagram analysis

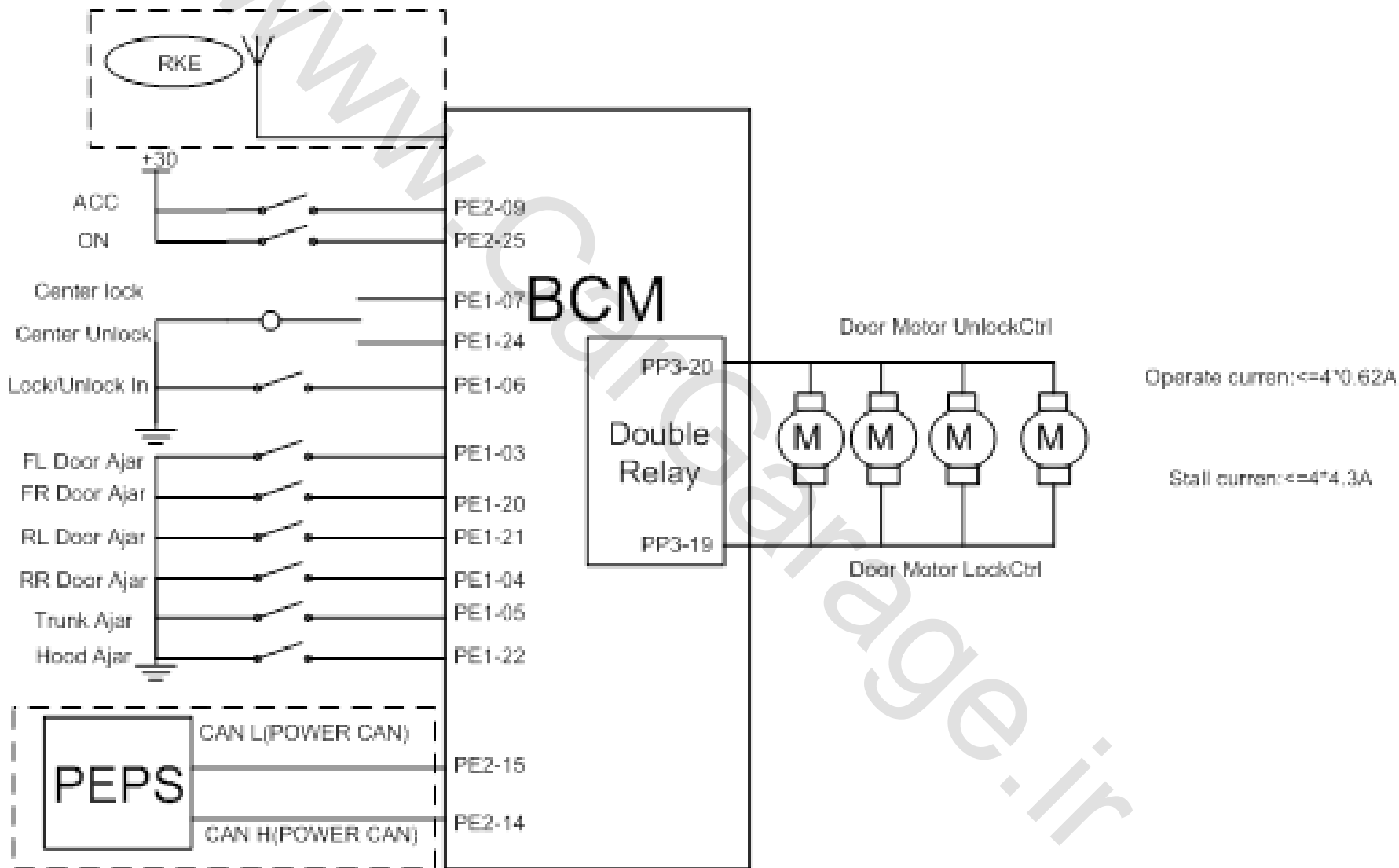

7

Electric rearview mirror

1. General description
2. System elements introduction
3. Circuit diagram analysis

1. General description

System composition

- The electric rearview mirror system is composed of following parts:
 - Left & right rearview mirror assembly (including two regulating motors)
 - Electrically-heated mirror
 - Rearview selection & redirection switch
 - Body control module (BCM)
 - AC control module



2. System elements introduction

Functions description :

The rear defroster can be only activated when all of following conditions are met:

(1) IGN-ON

(2) Rear defroster switch on AC panel is pressed when the rear defroster is deactivated.

BCM engages the external relay via inner low-side drive, and the rearview mirror and rear windshield defroster heating resistor start to work. After the defroster is activated for 20min., BCM will automatically turn off the output, with the pin at high resistance and relay disconnected.

If this function is activated, CAN signal Rear Dfst Cmd=1 will be sent to power train CAN, and Rear Dfst Sts=1 sent to body CAN.

System safety protection:

When the battery voltage remains lower than 11.5V for 5s, BCM will disconnect the control terminal of the relay. When the voltage is restored to 12.5V and this voltage is maintained for 15s, the system will be recovered.

7. Electric rearview mirror

2. System elements introduction

Type of signal:

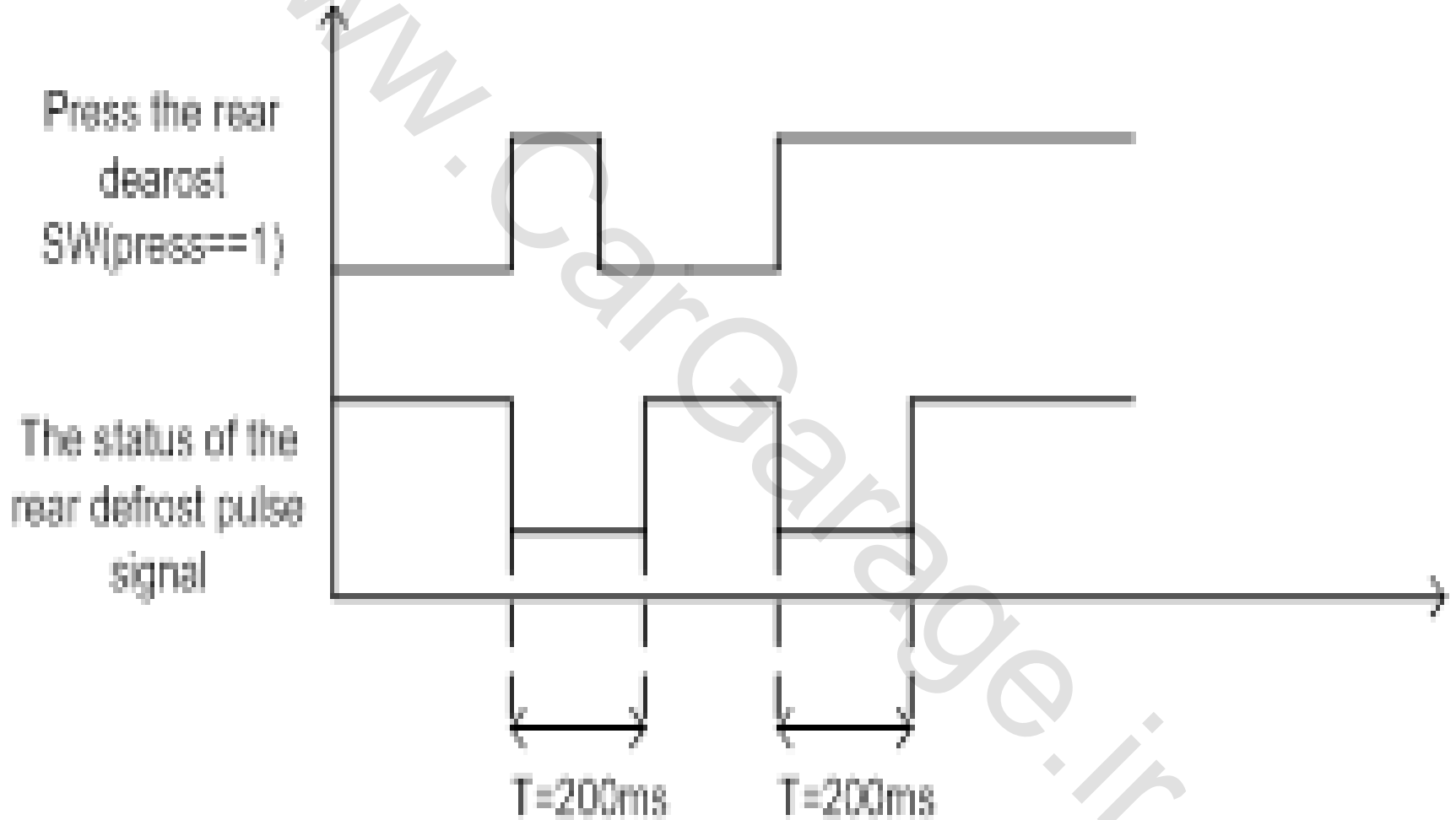

7. Electric rearview mirror

3. Circuit diagram analysis Defroster control principle

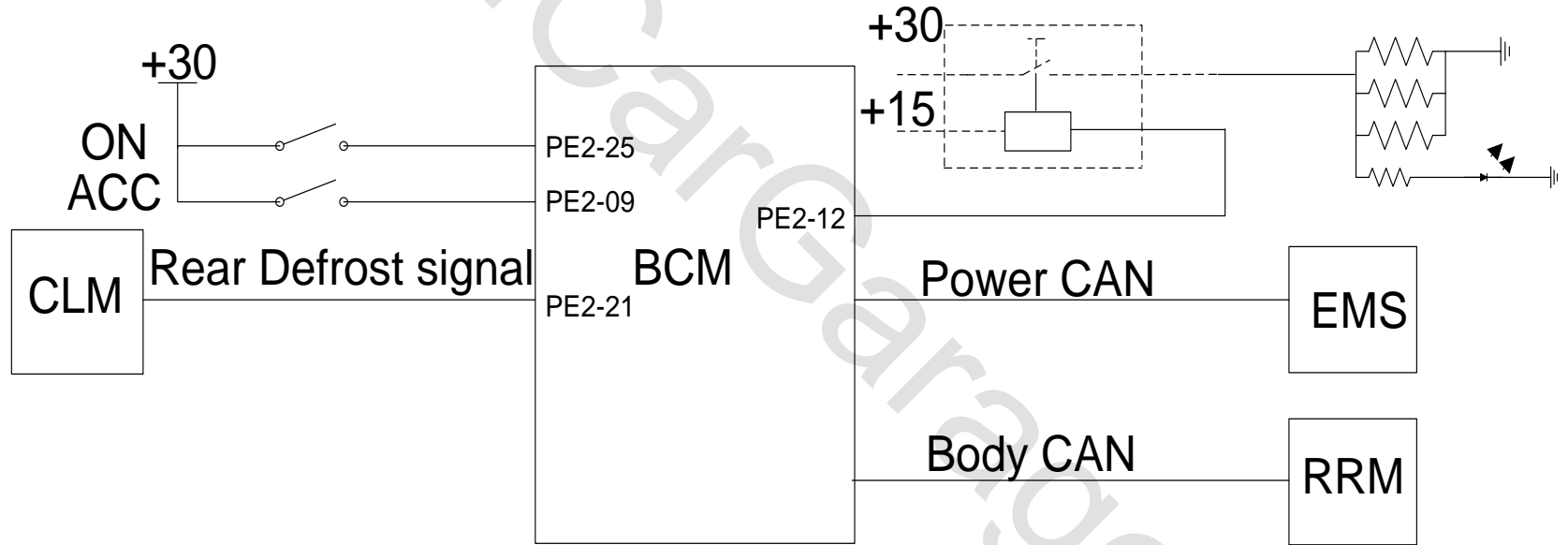

3. Circuit diagram analysis

Circuit diagram

- How to regulate the left rearview mirror in right and downward direction?

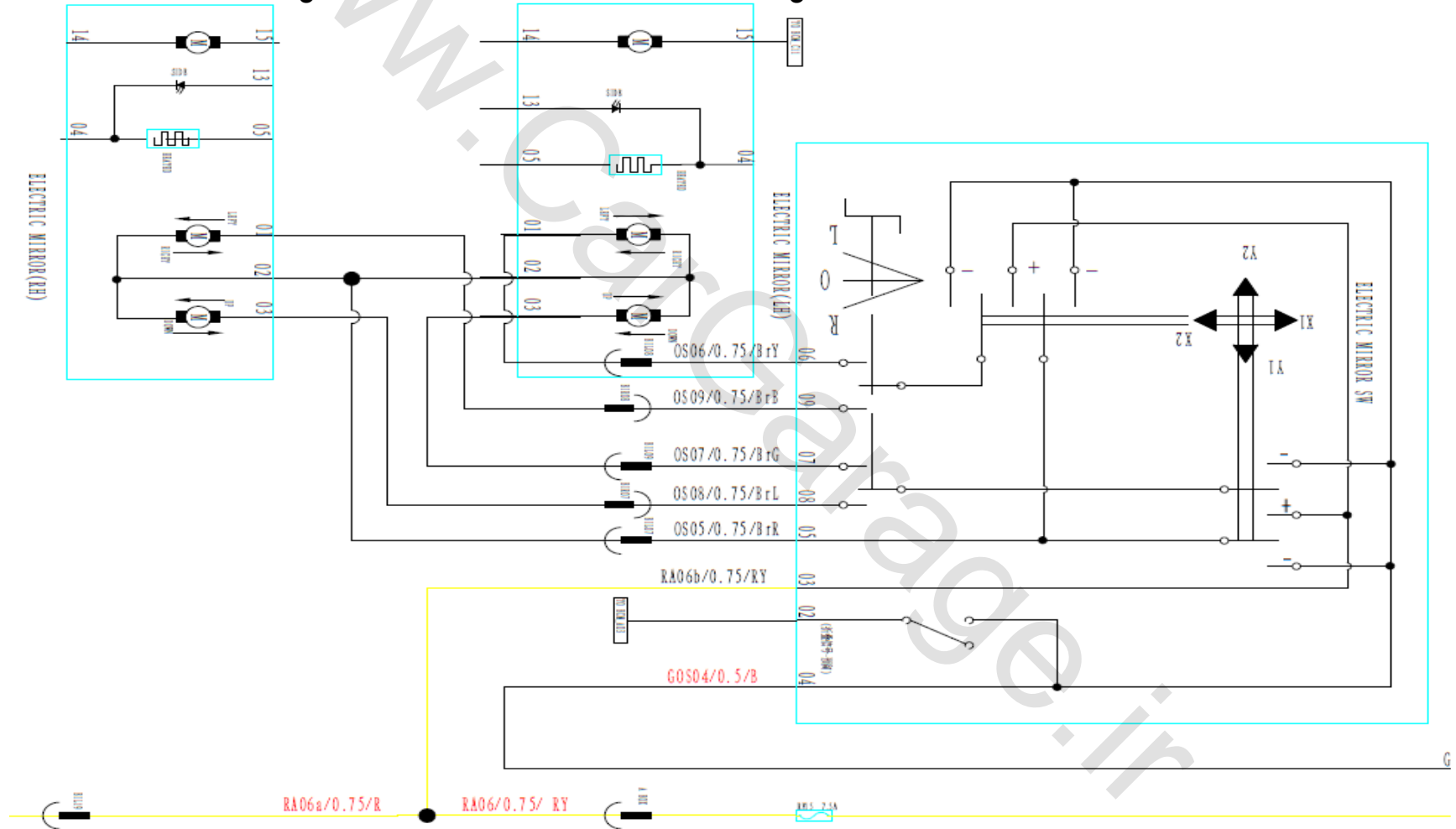

8

Sunroof control system

1. General description
2. Circuit diagram analysis
3. Troubleshooting

8. Sunroof control system

1. General description

T21 sunroof is an independent system(with anti-pinch function)

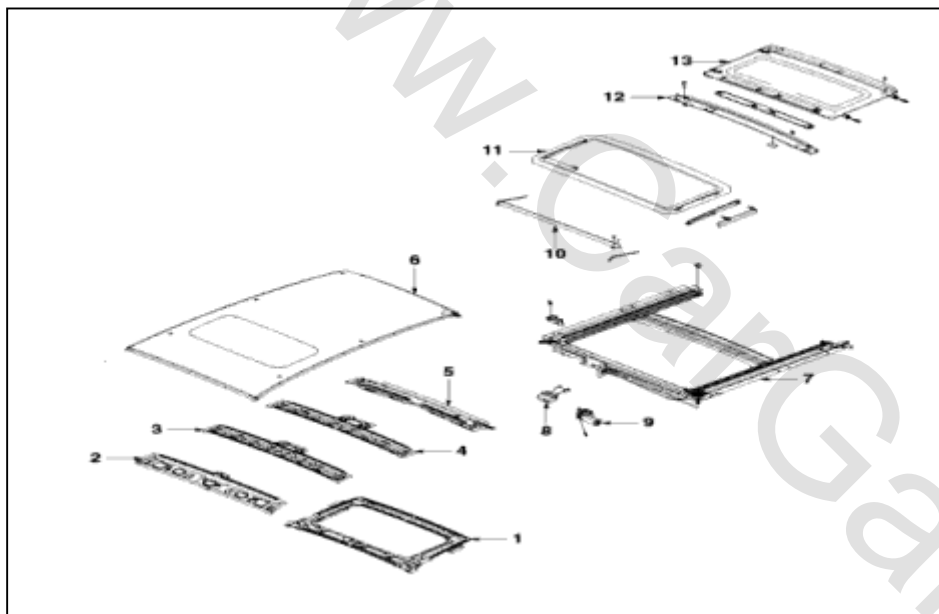

Sunroof composition:

- 1.Sunroof frame
- 2.Windshield frame
- 3.Sunroof central support
- 4.Sunroof rear support
- 5.Rear roof frame
6. Headlining
7. Sunroof housing
8. Sunroof control module
9. Sunroof motor
10. Sunroof deflector
11. Glass panel
12. Drain channel
13. Visor
14. Side cover inner (LH)
- 15.Side cover outer (RH)



8. Sunroof control system

1. General description

Sunroof switch



Sunroof initialization:

Operate the sunroof glass to fully open/tilt position, and hold open/tilt button for 15s above; then the sunroof can be recovered.

8. Sunroof control system

2. Circuit diagram analysis

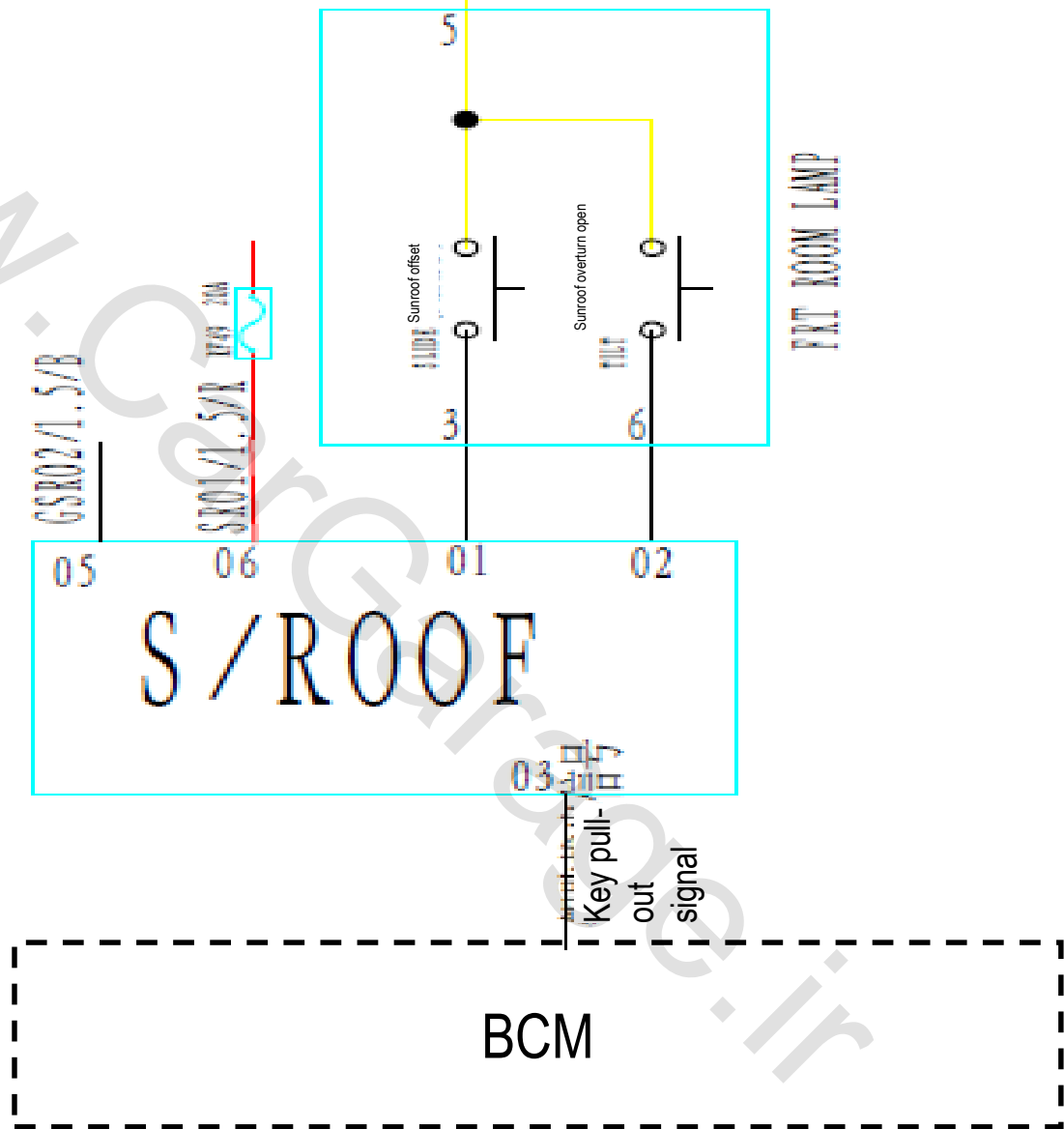

8. Sunroof control system

4. Troubleshooting

| Fault | Cause | Repair and operation method |
|------------------------------|--|---|
| Water leakage | The drain pipe is clogged or folded | Check conditions of drain pipe |
| | The distance from sunroof glass to the roof hole is too large or the glass height is poor | Regulate relative position of glass |
| Wind noise | The distance from sunroof glass to the roof hole is too large or the glass height is poor or the deflector fails | Rectify poor position of glass |
| Abnormal start and operation | Poor wires, fuses or earthing wires | Check wires, fuses and earthing wires |
| | Sunroof control unit and sunroof motor under poor conditions | Check and replace sunroof control unit and sunroof motor |
| | Sun shade panel is disengaged from guide rail, or the side cover is broken | Readjust sun shade panel, and install or replace the side cover |
| | There are foreign matters in the guide rail | Remove foreign matters |

8. Sunroof control system

4. Troubleshooting

| | | |
|---------------------------------|---|---|
| Wrong start | Sun shade panel is disengaged from guide rail, and the side cover is broken and comes into friction with guide rail | Readjust and refit sun shade panel, and refit the side cover (replace damaged parts) |
| | (A.T.S) The anti-pinch module functions abnormally | Check whether there is any interference between body and deflector, loosen the tensioned spring, and remove foreign matters in the rail |
| | The sunroof motor is under poor conditions | Replace the motor |
| Noise at start and in operation | Sun shade panel is disengaged from guide rail, and the side cover is broken to impede the movement | Readjust and refit sun shade panel, and refit the side cover (replace damaged parts) |
| | The drain pipe interferes with body | Bond buffer sponge around drain pipe |
| | The roof cover interferes with the sunroof frame | Apply silicon sealant or plastic sealant between roof cover and sunroof support |
| | The distance from sunroof glass to the roof hole is too large or the glass height is poor | Readjust glass height and relevant position |

9

Internal lighting system

1. General description
2. Circuit diagram analysis

1. General description

Components:

Internal lamps include key illumination lamp, front dome lamp, rear dome lamp and trunk lamp; The system is composed of relevant lamps, lamp switches and BCM, and is powered by BCM.



1. General description

Control strategy of internal lighting system

| | |
|-----------------------------|---|
| Dome lamp | <p>When the dome lamp switch is turned to door control position, the dome lamp control logic is as follows:</p> <ol style="list-style-type: none">① Remove the key, and the dome lamp will be lit for 3 minutes (for MT standard)② Open any door, and the dome lamp will be lit for 3 minutes;③ When the unlock signal is received, the dome lamp will be lit for 15s;④ With key at ON, after crash signal is received, dome lamp will be lit for 30min. |
| Trunk lamp | <p>The trunk lamp control is independent of ignition key position. When the trunk is opened, the trunk lamp will be lit; when it is closed, the lamp will be off. If the trunk remains open, the lamp will be lit for 15min and then off.</p> |
| Door ajar warning lamp | <p>With key at any position, open any front door, corresponding door ajar warning lamp will be lit; close the door, and this lamp will be off. (not for MT standard)</p> |
| PEPS key illumination light | <p>If parking lamp is lit, PEPS key illumination light will be lit to backlight lightness. When parking lamp is off, PEPS key illumination light works as following logic:</p> <ol style="list-style-type: none">① When any door is open, PEPS key illumination light will be lit for 3min.;② when receive unlock signal from remote controller or PE, PEPS key illumination light will be lit for 15s. |

1. General description

External fault protection function:

When the power supply of trunk lamp, keyhole illumination lamp and dome lamp is shorted to GND, BCM will disconnect the output of Battery Save to protect the electric circuit and store following fault code:

| DTC | DTC parameter | | | Description | Type of fault |
|----------|---------------|--------|-----|--|----------------|
| | HIGH | MIDDLE | LOW | | |
| B1027-11 | 90 | 27 | 11 | Battery Save output terminal control circuit | Shorted to GND |

2. Circuit diagram analysis

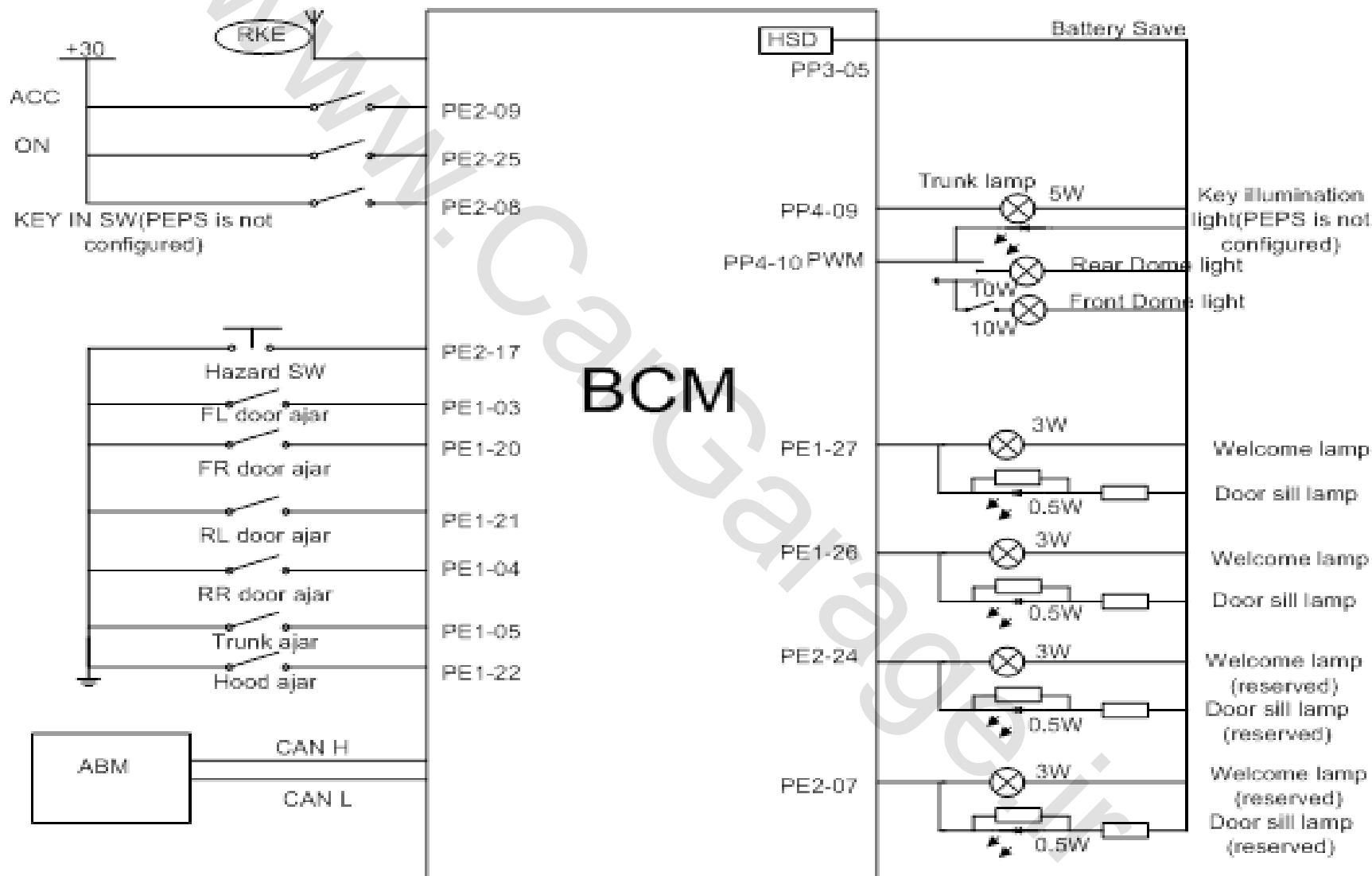

10

External lighting system

1. General description
2. Circuit diagram analysis
3. Function description – Follow Me Home

10. External lighting system

1. General description

External lighting system

External lighting system comprises following lamps:

- Position lamp, license plate lamp
- Front fog lamp, rear fog lamp
- High beam lamp, low beam lamp
- Left/right turn signal lamp
- Brake lamp, reversing lamp
- Hazard warning lamp function
- Emergency braking double-flash control etc.



10. External lighting system

2. Circuit diagram analysis

External lighting

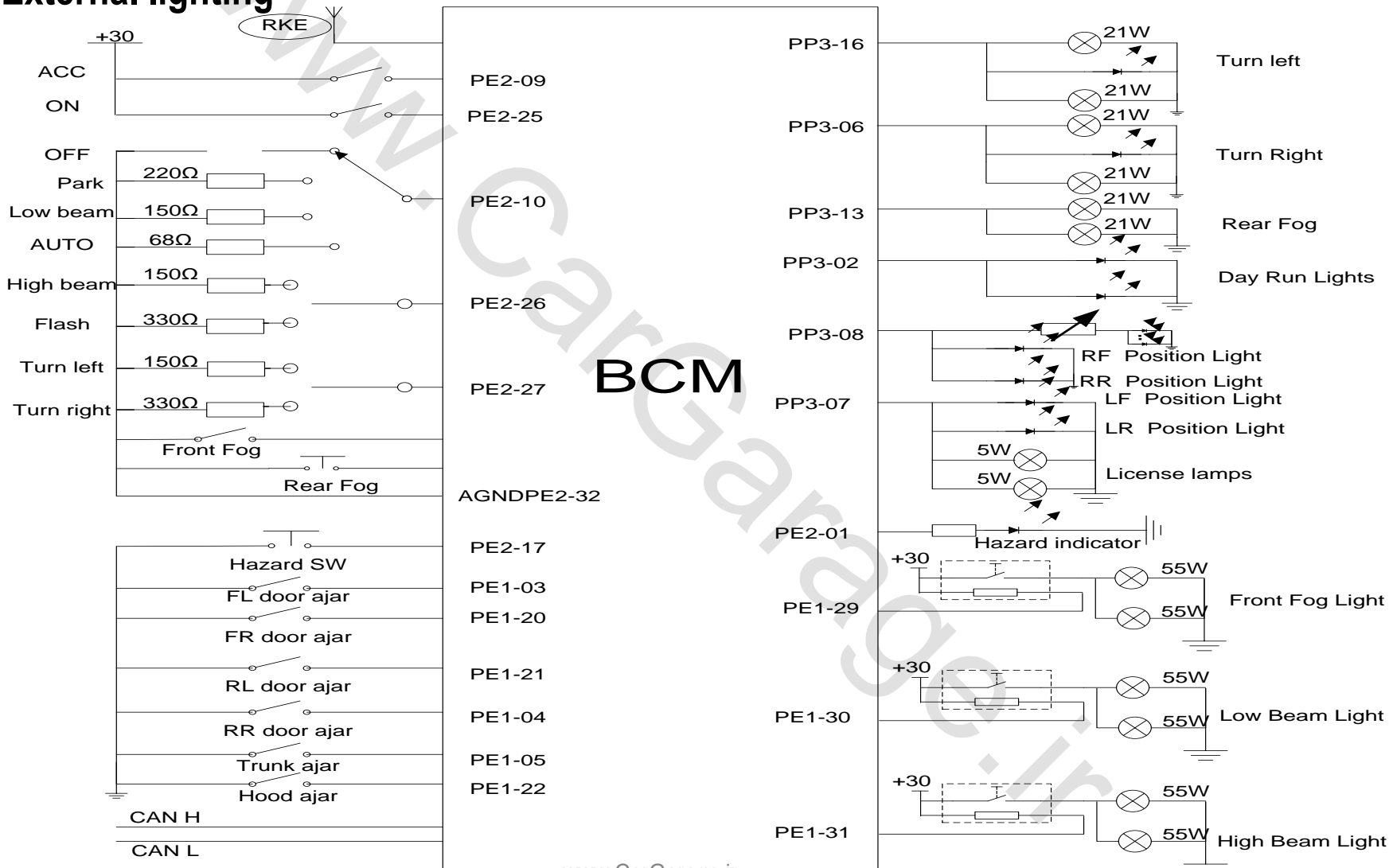

3. Function description – Follow Me Home

Function description of external lighting

| | |
|------------------|---|
| Turn signal lamp | <p>Turn signal lamp can be activated with ignition key at ON, at the frequency of 75 times per minute. The input switch is analog input latching switch type. If external resistance is 150Ω, left turn signal lamp will be lit; if 330Ω, right turn signal lamp will be lit.</p> <p>With turn signal lamp activated, the instrument receives CAN signal (LH Turn Signal Sts=1 or RH Turn Signal Sts=1) and turns on indicator lamp at the same flashing frequency with external turn signal lamp, accompanied with sound prompt.</p> |
| Lane change | <p>With the key at ON, operate the turn signal lamp within $50\text{ ms} < T < 600\text{ms}$, BCM will flash the turn signal lamp for 3 times on the corresponding side for lane changing.</p> <p>With lane change activated, the instrument receives CAN signal (LH Turn Signal Sts=1 or RH Turn Signal Sts=1) and turns on the indicator lamp at the same flashing frequency with external turn signal lamp, accompanied with sound prompt.</p> |

3. Function description – Follow Me Home

Function description of external lighting

| | |
|--------------------|--|
| Hazard lamp switch | <p>The hazard lamp is independent of the key position. If hazard lamp switch is turned on, left and right turn signal lamps will flash at the frequency of 75 flashes/minute. The hazard lamp switch is a micro switch.</p> <p>With the hazard lamp activated, the instrument receives CAN signal (LH Turn Signal Sts=1 or RH Turn Signal Sts=1) and turns on the indicator lamp at the same flashing frequency with external turn signal lamp, accompanied with sound prompt.</p> |
| Parking lamp | <p>With the key at ACC or ON, turn the multi-function switch to parking lamp position, and BCM will turn on parking lamp.</p> <p>With the key at ON, turn the multi-function switch to low beam position, and BCM will turn on parking lamp.</p> <p>With the key at OFF, turn the multi-function switch to parking lamp switch, and the parking lamp will be lit.</p> <p>With the parking lamp lit, body CAN signal Parking Light Sts=1 will be sent to the instrument to illuminate the parking lamp indicator.</p> |

3. Function description – Follow Me Home

Function description of external lighting

| | |
|----------------|--|
| Low beam lamp | <p>With the key at ON, turn on the low beam lamp switch, and BCM will turn on low beam lamp.</p> <p>With the low beam lamp lit, BCM will send CAN signal Low Beam Sts=1 to body CAN and power CAN respectively.</p> |
| High beam lamp | <p>With the key at ON and low beam lamp on, turn on the high beam lamp switch, and the high beam lamp will be activated.</p> <p>With the high beam lamp lit, BCM will send CAN signal High Beam Sts=1 to body CAN and power CAN respectively.</p> <p>If the engine is started with the high beam lamp on, the high beam lamp will be off during startup; after the startup, it will be lit again. However, CAN signal remains valid.</p> |
| Flash | <p>With the key at ON, operate flash switch, and the high beam lamp will be activated as flash, with CAN signal High Beam Sts=1 sent to body CAN and power CAN respectively.</p> <p>If the engine is started with the flash on, the high beam lamp will be off during startup; after the startup, it will be lit again. However, CAN signal remains valid.</p> |

3. Function description – Follow Me Home

Function description of external lighting

| | |
|-----|--|
| FMH | <p>If lash switch is moved for less than 2s within 2min. after the key is turned from ON to OFF. Upon each movement, the parking lamp, low beam lamp and license plate lamp will be activated for 30s, at most 240s.</p> <p>With this function valid, move the switch for more than 2s, and it will be deactivated.</p> |
| LMC | <p>If following conditions are met, BCM will turn on parking lamp, low beam lamp and license plate lamp for 1 minute:</p> <ol style="list-style-type: none">① With the key at OFF;② In the same ignition cycle (from ON to ACC to OFF)③ FMH is not disabled by pulling flash switch for more than 2s.④ 4 doors are closed.⑤ The unlock signal from remote controller is received. <p>(Remarks: MT comfort/luxury, CVT comfort/luxury are equipped with PEPS, and this function can be activated via PE smart entry and remote controller).</p> |

3. Function description – Follow Me Home

Function description of external lighting

| | |
|----------------|--|
| Front fog lamp | <p>When following conditions are met, BCM will turn on front fog lamp (BCM controls front fog lamp external relay via low-side drive):</p> <ul style="list-style-type: none">① Ignition key at ON② Parking lamp on③ Front fog lamp switch turned on (latching switch) <p>When the front fog lamp is lit, BCM will send CAN signal Front Fog Light Sts=1 to body CAN.</p> |
| Rear fog lamp | <p>When following conditions are met, BCM will turn on rear fog lamp (BCM outputs high voltage and internal relay inputs high voltage):</p> <ul style="list-style-type: none">① Ignition key at ON② Parking lamp on③ Front fog lamp switch or low beam lamp turned on④ Rear fog lamp switch turned on (rear fog lamp switch is inching switch) <p>When the rear fog lamp is lit, BCM will send CAN signal Rear Fog Light Sts=1 to body CAN.</p> |

3. Function description – Follow Me Home

Function description of external lighting

| | |
|---|--|
| Low beam lamp, high beam lamp, front fog lamp | Electric circuit reliability of low beam lamp, high beam lamp and front fog lamp are provided by following items: ① External relay output; ② BCM low-side controls relay coil; ③ External relay is secured by the fuse. |
|---|--|

Emergency braking hazard lamps double frequency flash

| | |
|----------|--|
| Function | <p>When vehicle speed indicated on the gauge reaches 60km/h, in the case of emergency braking (the speed change exceeds 22km/h within 1s), left and right turn signal lamps will double frequency flash, and left and right turn signal indicator lamps and hazard lamp switch indicator will flash synchronously. With this function activated, the flashing can be stopped via following 3 ways:</p> <ul style="list-style-type: none">① The key is turned to OFF;② The accelerator pedal is depressed, and the car is to be accelerated;③ Press hazard lamp switch; <p>Remarks: BCM detects the signal of accelerator pedal by detecting “Gas Pedal Position” signal from OXFA of CAN signal.</p> |
|----------|--|

3. Function description – Follow Me Home

Function description of external lighting

External fault protection:

External turn signal lamp

If any turn signal lamp fails while other turn signal lamps work normally, the indicator lamp will flash at double frequency of CAN signal to remind the user of the failure of turn signal lamp in question.
When the lamp output PIN is shorted to GND, drive chip will automatically cut off the output to protect electric circuit.

The external turn signal supports following fault codes:

| DTC | DTC parameter | | | Description | Type of fault |
|----------|---------------|--------|-----|--------------------------------|----------------------------|
| | HIGH | MIDDLE | LOW | | |
| B1001-11 | 90 | 01 | 11 | Left turn signal lamp circuit | Shorted to GND |
| B1001-13 | 90 | 01 | 13 | | Output open circuit |
| B1001-19 | 90 | 01 | 19 | | Exceedance of output limit |
| B1002-11 | 90 | 02 | 11 | Right turn signal lamp circuit | GND |
| B1002-13 | 90 | 02 | 13 | | Shorted to GND |
| B1002-19 | 90 | 02 | 19 | | Exceedance of output limit |

3. Function description – Follow Me Home

Function description of external lighting

Parking lamp When the parking lamp output terminal is shorted to GND, BCM drive chip will cut off the output:

The parking lamp control circuit supports following fault code strategy:

| DTC | DTC parameter | | | Description | Type of fault |
|----------|---------------|--------|-----|----------------------------|----------------------------|
| | HIGH | MIDDLE | LOW | | |
| B1003-11 | 90 | 03 | 11 | Left parking lamp circuit | Shorted to GND |
| B1003-13 | 90 | 03 | 13 | | Output open circuit |
| B1003-19 | 90 | 03 | 19 | | Exceedance of output limit |
| B1004-11 | 90 | 04 | 11 | Right parking lamp circuit | Shorted to GND |
| B1004-13 | 90 | 04 | 13 | | Output open circuit |
| B1004-19 | 90 | 04 | 19 | | Exceedance of output limit |

3. Function description – Follow Me Home

Function description of external lighting

Rear fog lamp output circuit is protected by a 15A fuse which will be firstly burnt in the case of short circuit.

The rear fog lamp output supports following fault code strategies:

| DTC | DTC parameter | | | Description | Type of fault |
|----------|---------------|--------|-----|-----------------------|---------------------|
| | HIGH | MIDDLE | LOW | | |
| B1008-13 | 90 | 08 | 13 | Rear fog lamp circuit | Output open circuit |
| B1008-71 | 90 | 08 | 71 | | Relay seized |

10. External lighting system

3. Function description – Follow Me Home Circuit diagram of brake lamp

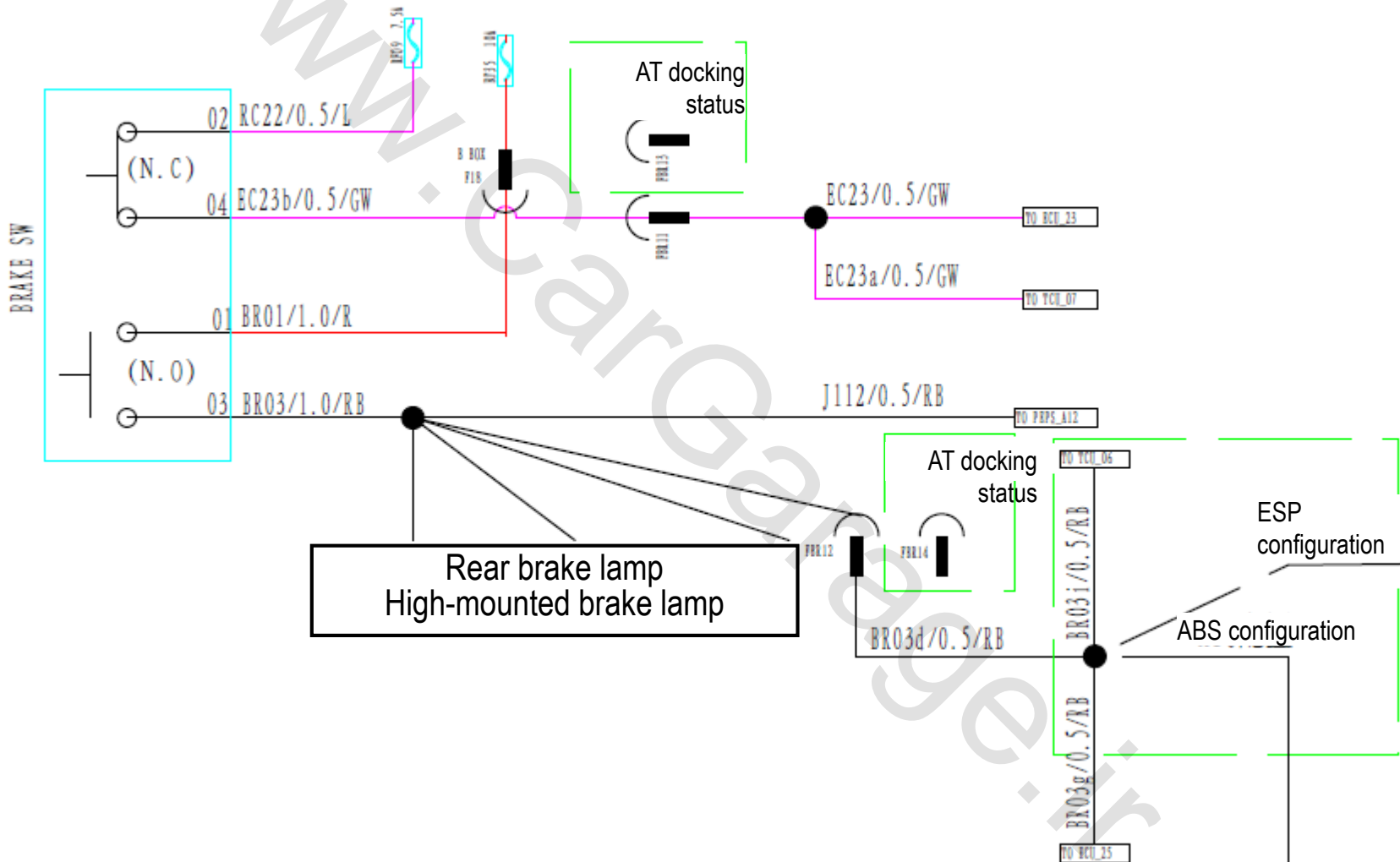

11

Wiper system

1. System elements introduction
2. Control strategy
3. Fault diagnosis
4. Circuit diagram analysis

11. Wiper system

1. System elements introduction

System composition:

- Wiper motor
- Wiper connecting rod
- Two wiper arms and blades
- Two washer nozzles
- Washer tank and pump
- Wiper washer lever switch

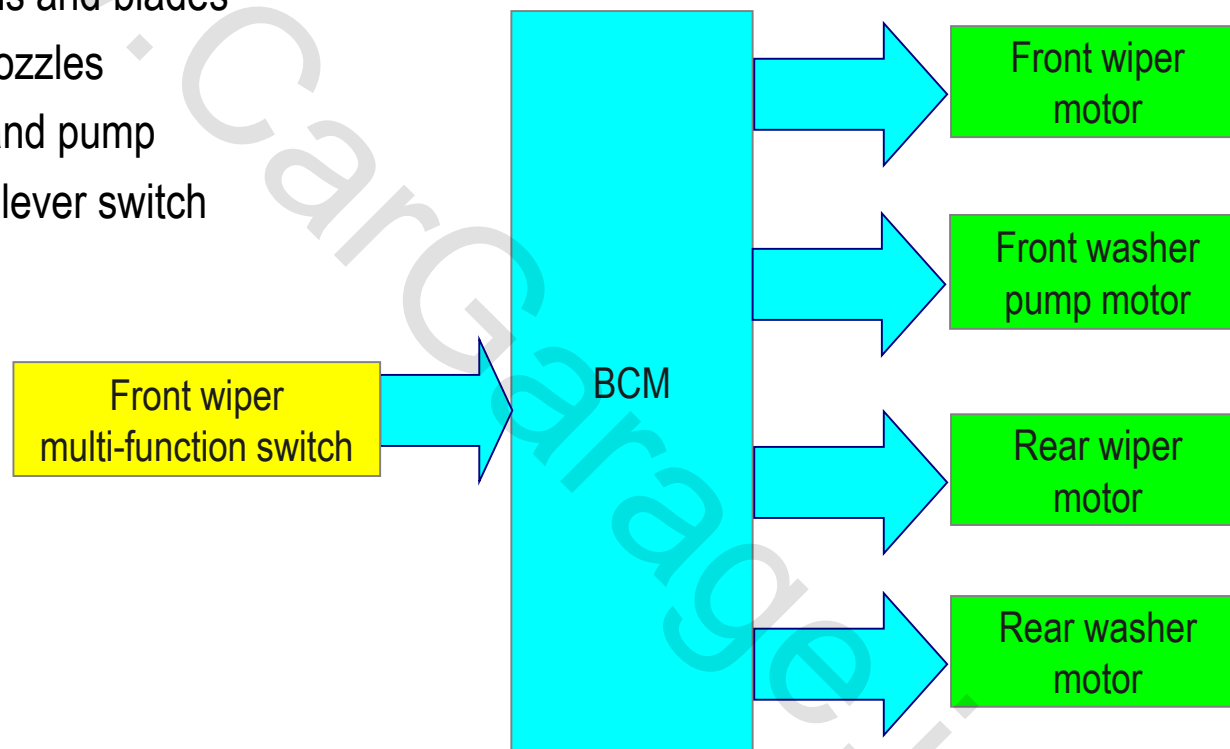

11. Wiper system

1. System elements introduction

Wiper motor

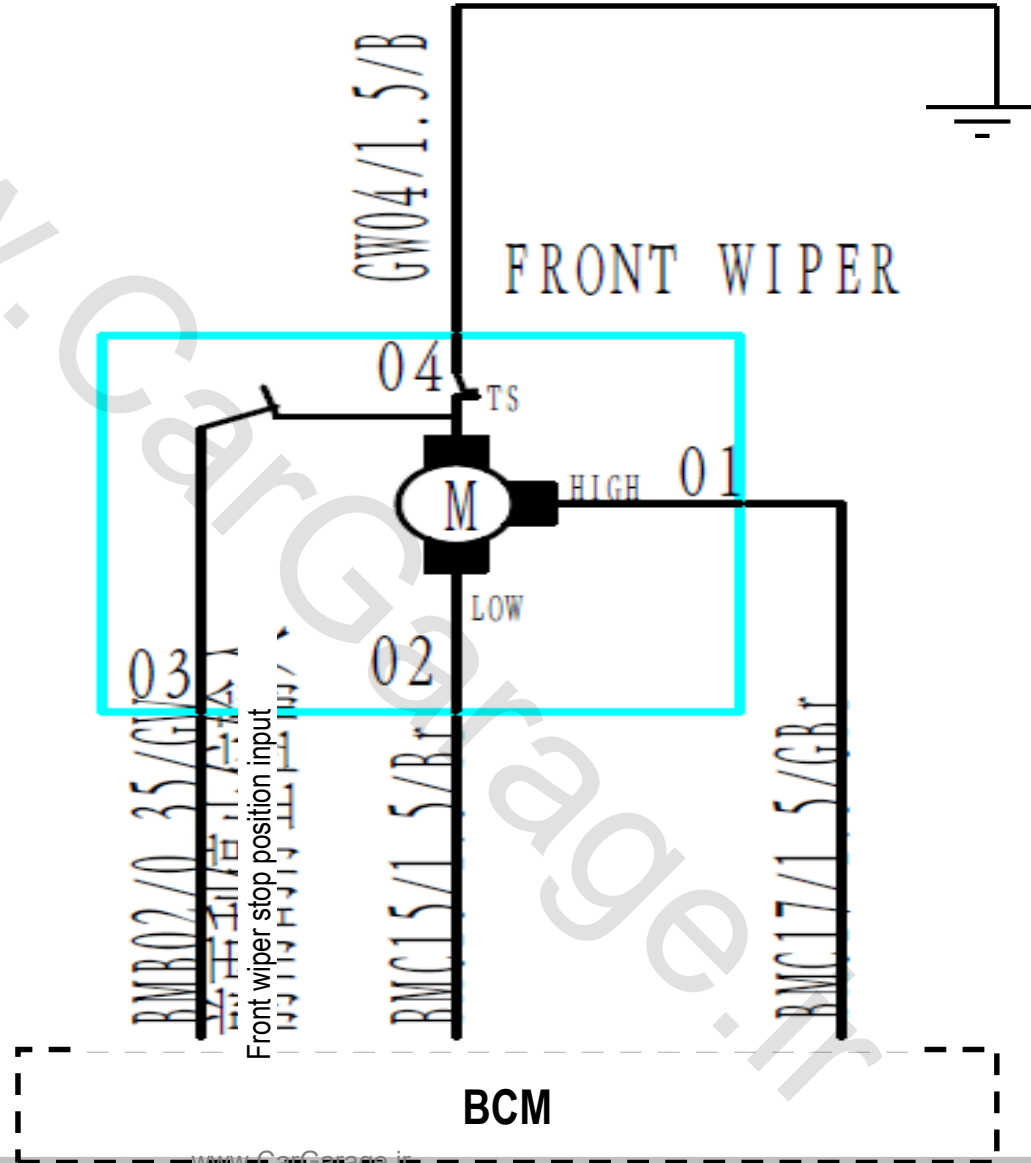

11. Wiper system

1. System elements introduction

Rear wiper motor

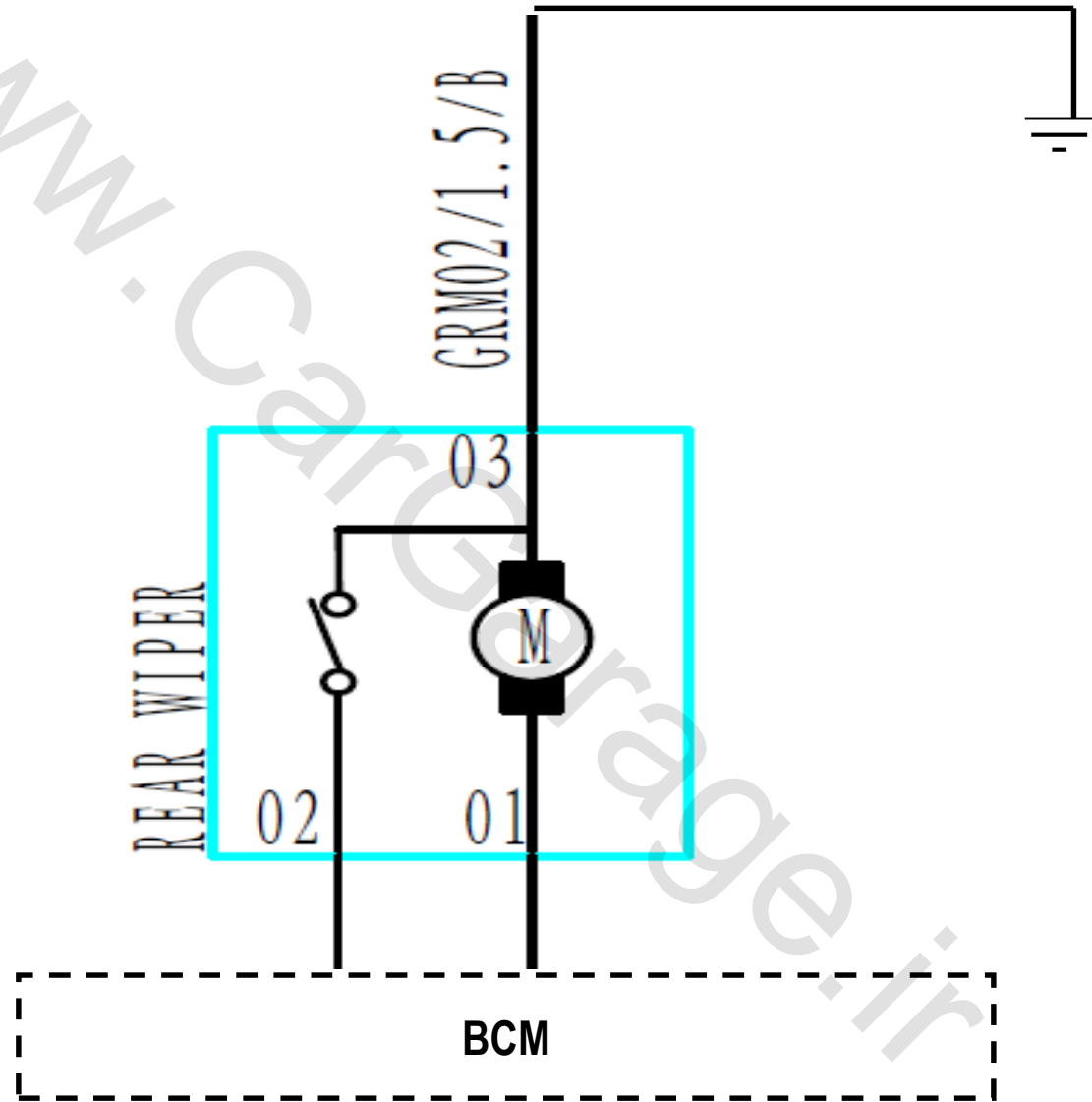

11. Wiper system

1. System elements introduction

Wiper motor

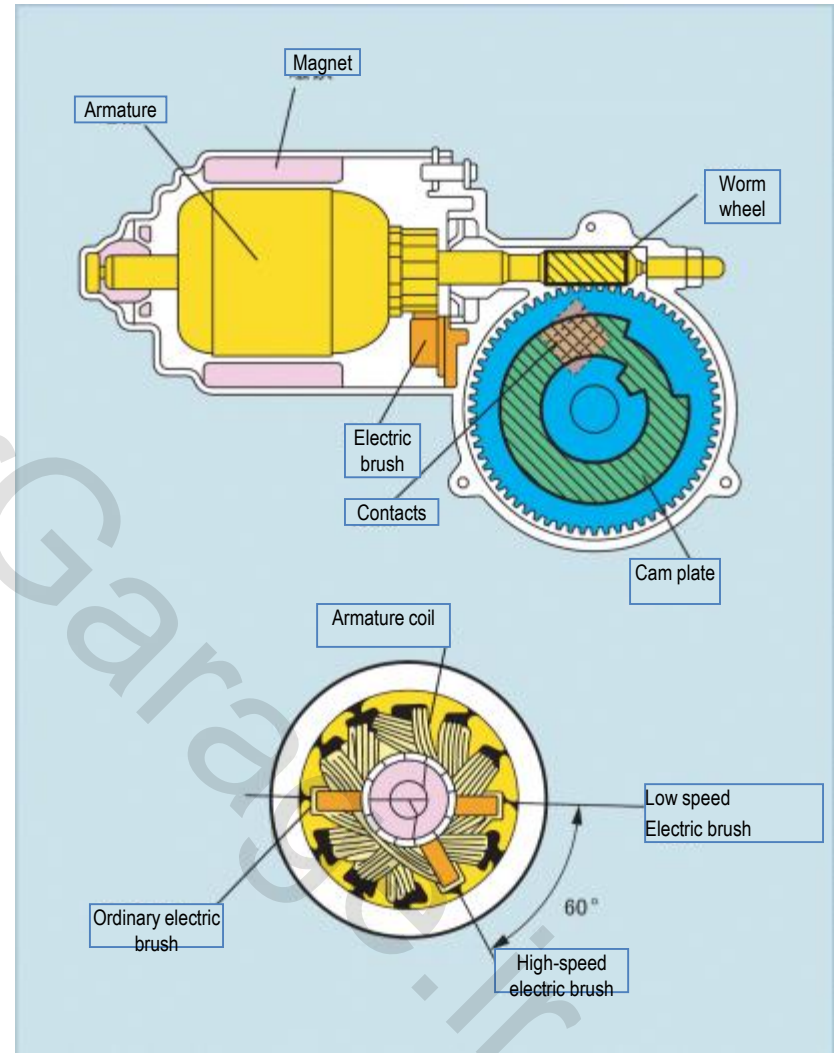

11. Wiper system

1. System elements introduction

Wiper motor

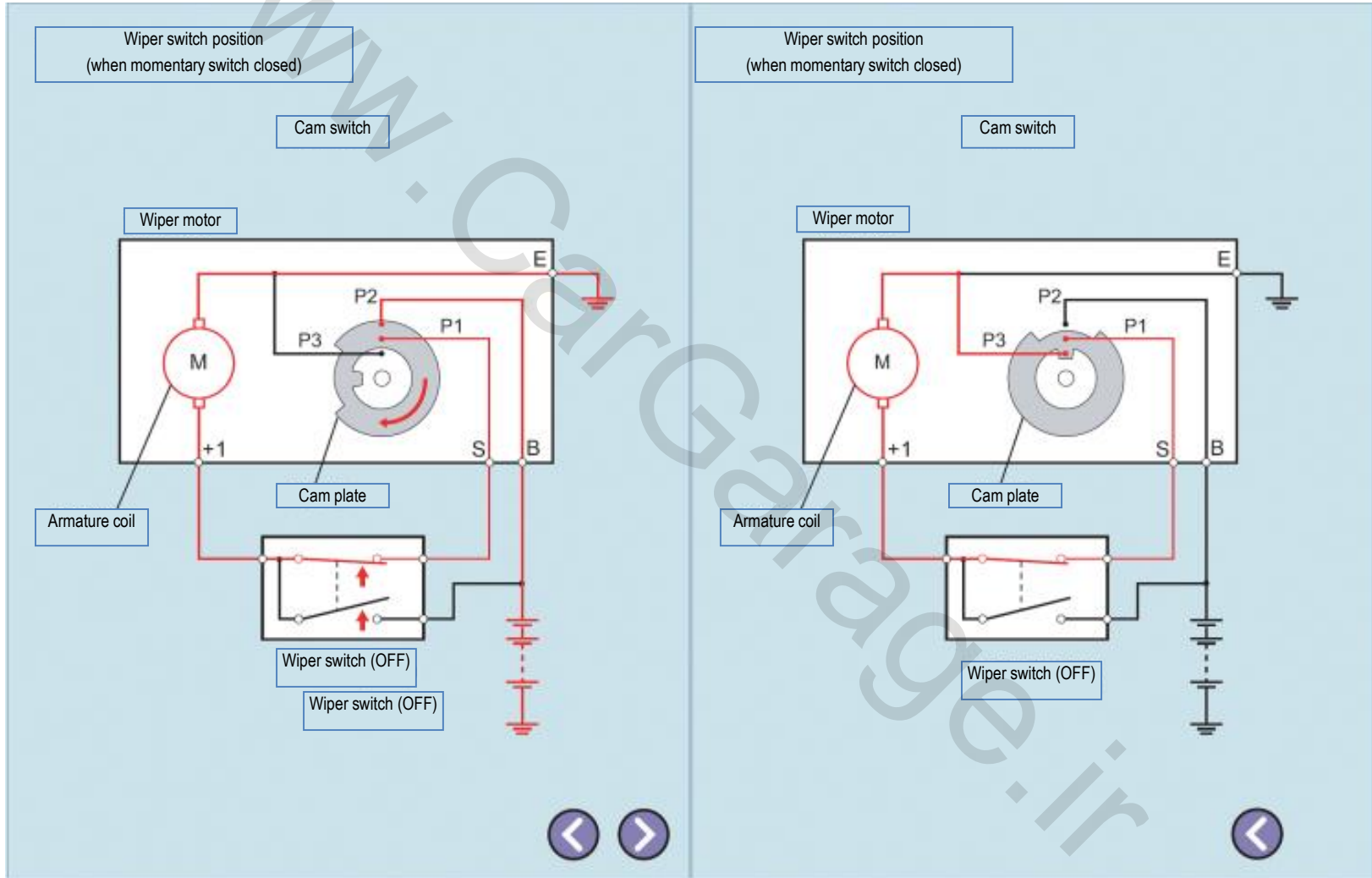

11. Wiper system

1. System elements introduction

Front wiper switch

Front wiper/front washer is controlled by BCM to execute following functions:

- HI;
- LO;
- INT (Time interval is adjustable);
- MIST;
- Washer;



11. Wiper system

1. System elements introduction

Circuit diagram of front wiper

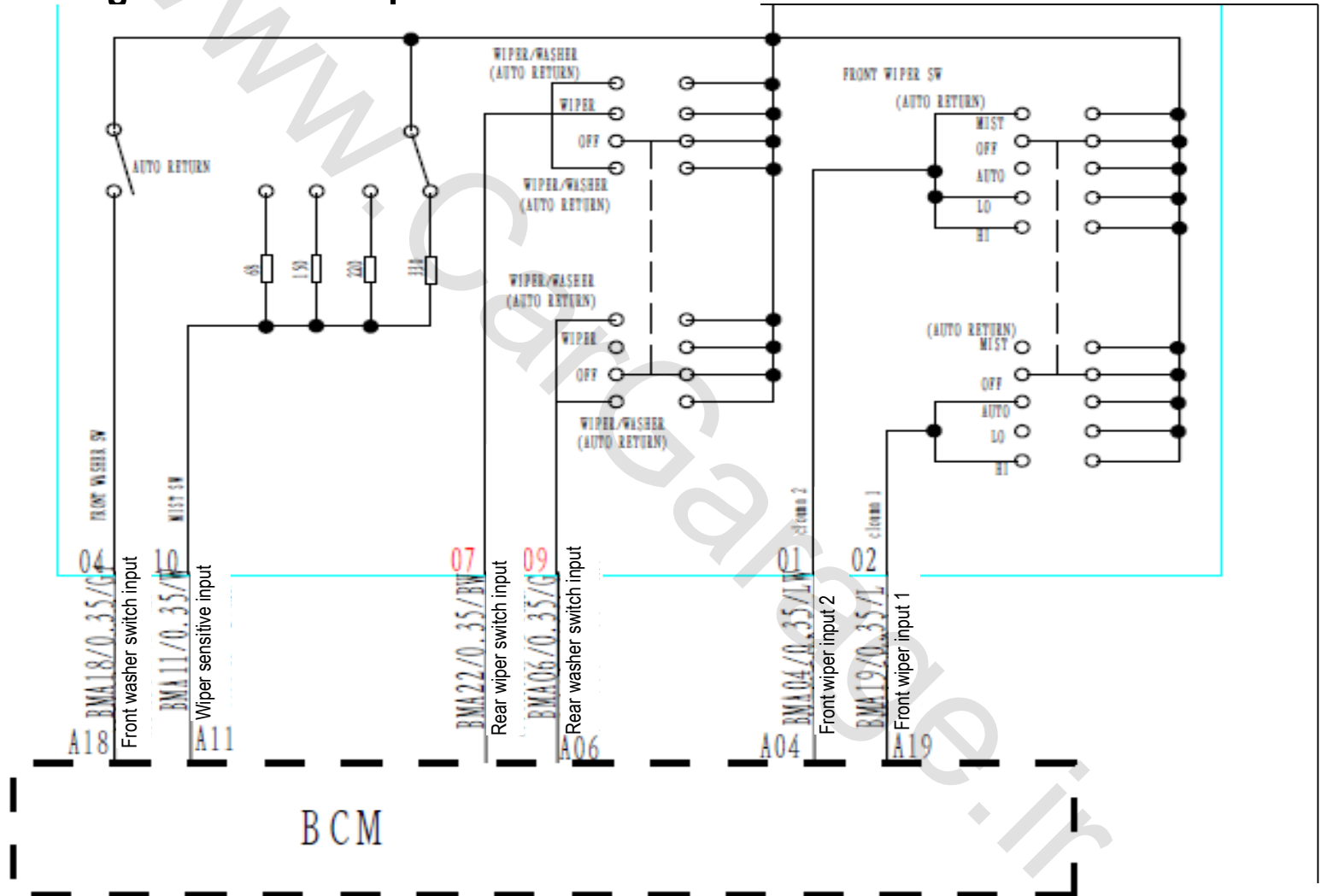

2. Control strategy

Front wiper control strategy

| | |
|---------|---|
| HI | <ol style="list-style-type: none">1) With ACC=ON, move wiper switch to HI, and wiper will work at high speed;2) The wiper will immediately stop when:<ul style="list-style-type: none">➤ BCM detects wiper stop input signal and wiper switch is at OFF;➤ ACC=OFF, the wiper will immediately stop; |
| LO/MIST | <ol style="list-style-type: none">1) LO and MIST share the same PIN;2) With ACC =ON, when BCM detects this valid PIN, wiper will work at low speed;3) The wiper will immediately stop when:<ul style="list-style-type: none">➤ BCM detects wiper stop input signal and wiper switch is at OFF;➤ ACC=OFF, the wiper will immediately stop; |
| INT | <ol style="list-style-type: none">1) With ACC = ON, move the wiper switch to INT, and wiper will output at low speed till the wiper stop input signal is received to fulfill a wiping task;2) Once the wiper stop input signal is detected, the wiper low-speed output will be stopped till the preset time interval is over, after which the wiper will act again;3) The wiper time interval can be regulated by wiper sensitivity switch. There are 4 time intervals: 2s, 4s, 8s and 13s. |

2. Control strategy

Front wiper control strategy

- | | |
|--------|--|
| Washer | <ol style="list-style-type: none">1) With the key at ON, the washer can work;2) With the key at ON and wiper not activated, turn on washer switch, and the wiper will be started at low speed after water injection for $0.5s \pm 50ms$. After the switch is turned off, the wiper will wipe for 3 times at low speed. |
|--------|--|

Rear wiper control strategy

- | | |
|-----------------------|---|
| Continuous rear wiper | <p>With the key at ON, turn the rear wiper switch to ON, and the rear wiper will continuously work.</p> <ul style="list-style-type: none">➤ The wiper will immediately stop when BCM detects rear wiper stop input signal and the rear wiper switch is at OFF;➤ The wiper will immediately stop when the key is turned to OFF. |
|-----------------------|---|

- | | |
|--------|--|
| Washer | <p>With the key at ON, when the rear wiper switch is turned to washer from OFF, the water injector will spray water; 0.5s later, the rear wiper will work continuously. Release the switch, and the wiper will continuously work 3 cycles.</p> |
|--------|--|

3. Fault diagnosis

External fault protection function:

Front wiper (HI, LO) motor, front washer motor, rear wiper motor, and rear washer motor are driven by BCM relays and protected with fuses.

Following fault code strategies are supported:

| DTC | DTC parameter | | | Description | Type of fault |
|----------|---------------|--------|-----|------------------------------|---------------------|
| | HIGH | MIDDLE | LOW | | |
| B1014-71 | 90 | 14 | 71 | Front wiper LO circuit | Relay seized |
| B1015-71 | 90 | 15 | 71 | Front wiper HI circuit | Relay seized |
| B1016-71 | 90 | 16 | 71 | Rear wiper control circuit | Relay seized |
| B1017-13 | 90 | 17 | 13 | Front washer control circuit | Output open circuit |
| B1017-71 | 90 | 17 | 71 | | Relay seized |
| B1018-13 | 90 | 18 | 13 | Rear washer control circuit | Output open circuit |
| B1018-71 | 90 | 18 | 71 | | Relay seized |

11. Wiper system

4. Circuit diagram analysis

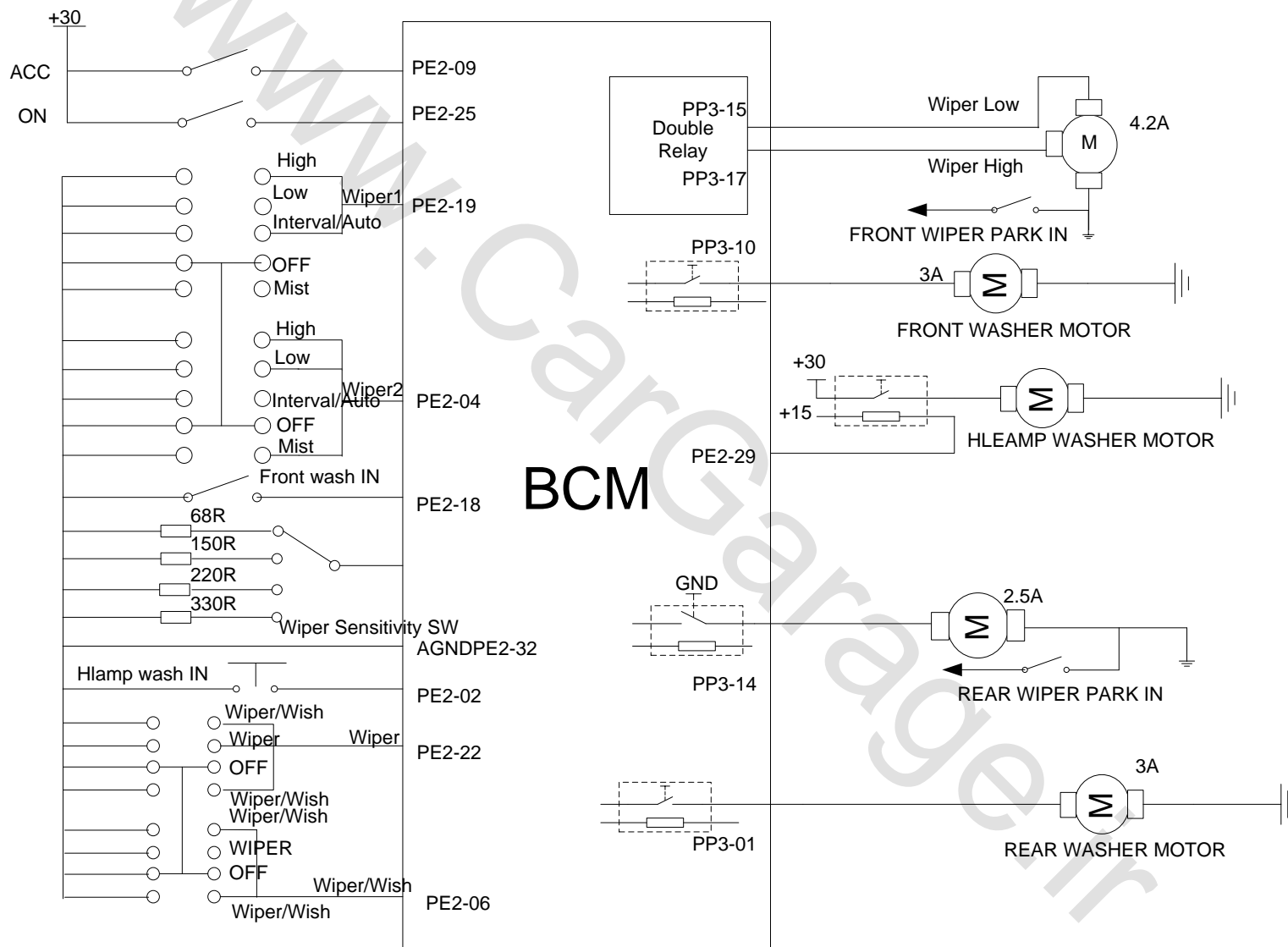

12

Instrument cluster

1. General description
2. Function description

12. Instrument cluster

1. General description Instrument cluster



1. General description

Principle block diagram

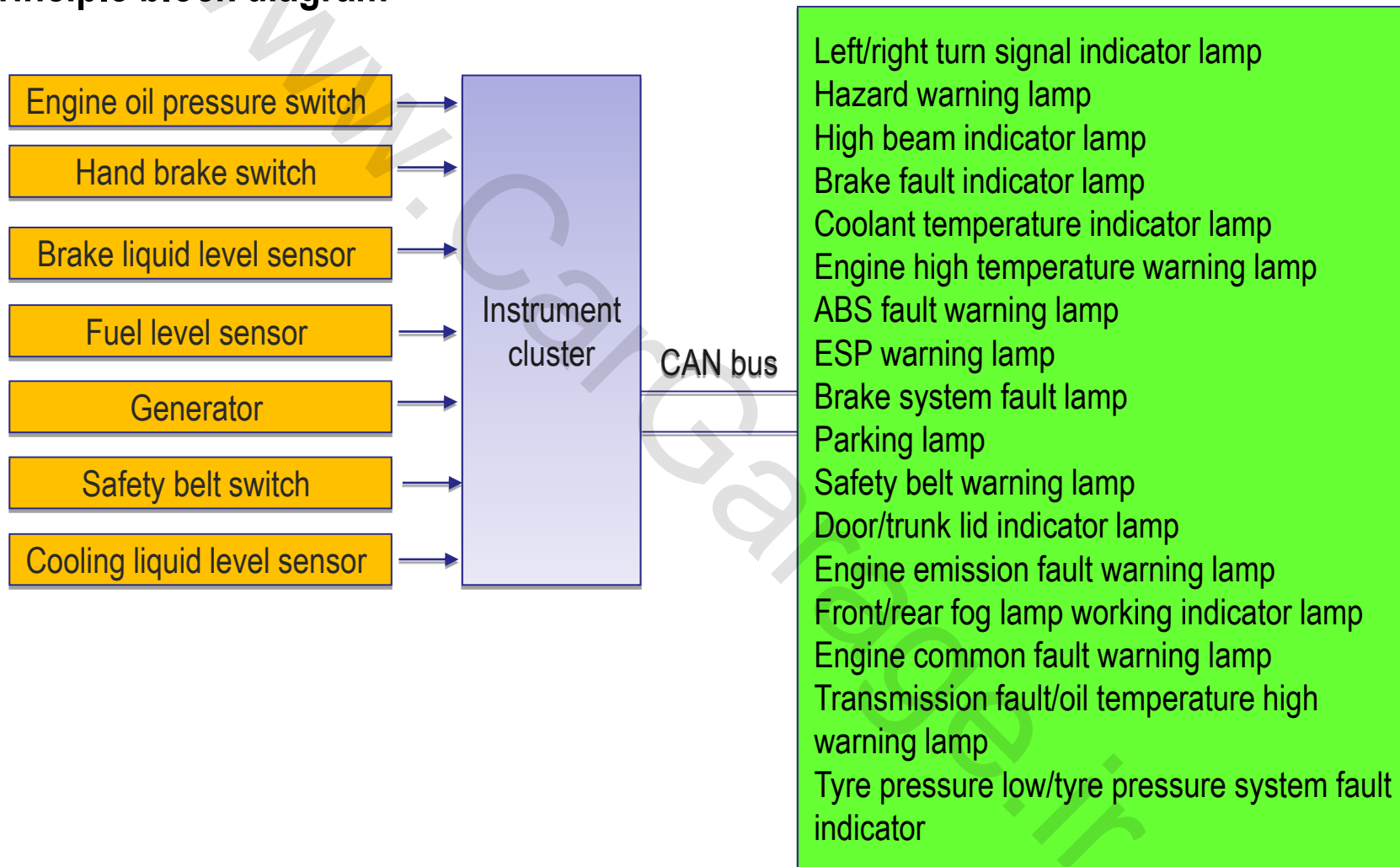

12. Instrument cluster

1. General description

Instrument cluster power management

| Power status | Conditions | | | | Description on power management mode |
|--------------|------------|----------------------------|------------------|------------|--|
| | KL15/IGN | KL30/ Battery power supply | Network status | Remarks | |
| D1 | ON | ON | Wake up | IGN SW ON | ICM (instrument) works normally |
| D2 | OFF | ON | Wake up | IGN SW ACC | A bright frame is provided around LCD screen. The screen will not display follow me home, total mileage, clock etc. ICM can realize following functions: hazard warning lamp indicator, parking lamp indicator, PEPS warning prompt text, buzzer sound, door ajar indicator. |
| D3 | OFF | ON | Wakeup/ Sleep | IGN SW OFF | (1) LCD screen backlight can be activated by follow me home, PEPS warning indicator and door ajar indicator. When any of the warning indicators is activated, the backlight will be lit; otherwise it will be extinguished immediately. When the indication by parking lamp and hazard warning lamp is desired, the corresponding indicator lamp will be lit. The key-in-ignition buzz can be realized. (2) Upon the receipt of network sleep signal, ICM will sleep and close all outputs without any indication, with the stationary current of no more than 1.5mA. |
| D4 | OFF | OFF | / | / | ICM doesn't work |

2. Function description

Instrument cluster backlight control

With the parking lamp on, the PWM signal input by backlight switch will be controlled by the micro processor to realize the backlight control. When the backlight is regulated to a certain point, PWM signal of backlight switch will have a fluctuation of 5%, and the instrument cluster needs damping.

PWM input signal:

Frequency: $80 \pm 10\%$ Hz

Duty ratio: $10\% \pm 4\% \sim 90\% \pm 5\%$

Pin 12 backlight is a PWM signal input to the instrument by the control switch.

When the instrument receives this backlight signal, it will regulate the brightness of backlight of dial of the instrument cluster as the case may be, and it is also necessary to regulate LCD backlight brightness to keep consistent with car backlight color and brightness. When the backlight is off, the brightness of instrument cluster LCD is 80%.

2. Function description

Instrument backlight control and backlight illumination logic

| Status | Input | | Display | |
|--------|------------|------------------------------|--|--|
| | Power mode | Pin 12 backlight, PWM signal | LCD backlight | Pointer, dial backlight |
| 1 | D1(ON) | ON | The brightness is adjustable. The max. brightness of LCD screen backlight is 25 ± 7 cd/ m ² (night mode). | |
| 2 | D2 (ACC) | | | |
| 3 | D3 (OFF) | | | |
| 4 | D1 (ON) | OFF | The brightness is unadjustable, and the brightness is at its maximum value (daytime mode of LCD) | |
| 5 | D2 (ACC) | | The brightness is unadjustable, and the brightness is at its max value (daytime mode) | |
| 6 | D3 (OFF) | | OFF (LCD screen backlight is not activated) | Max. brightness (LCD screen backlight is activated) |
| 7 | D4 | / | OFF | |

12. Instrument cluster

2. Function description

Instrument cluster backlight control

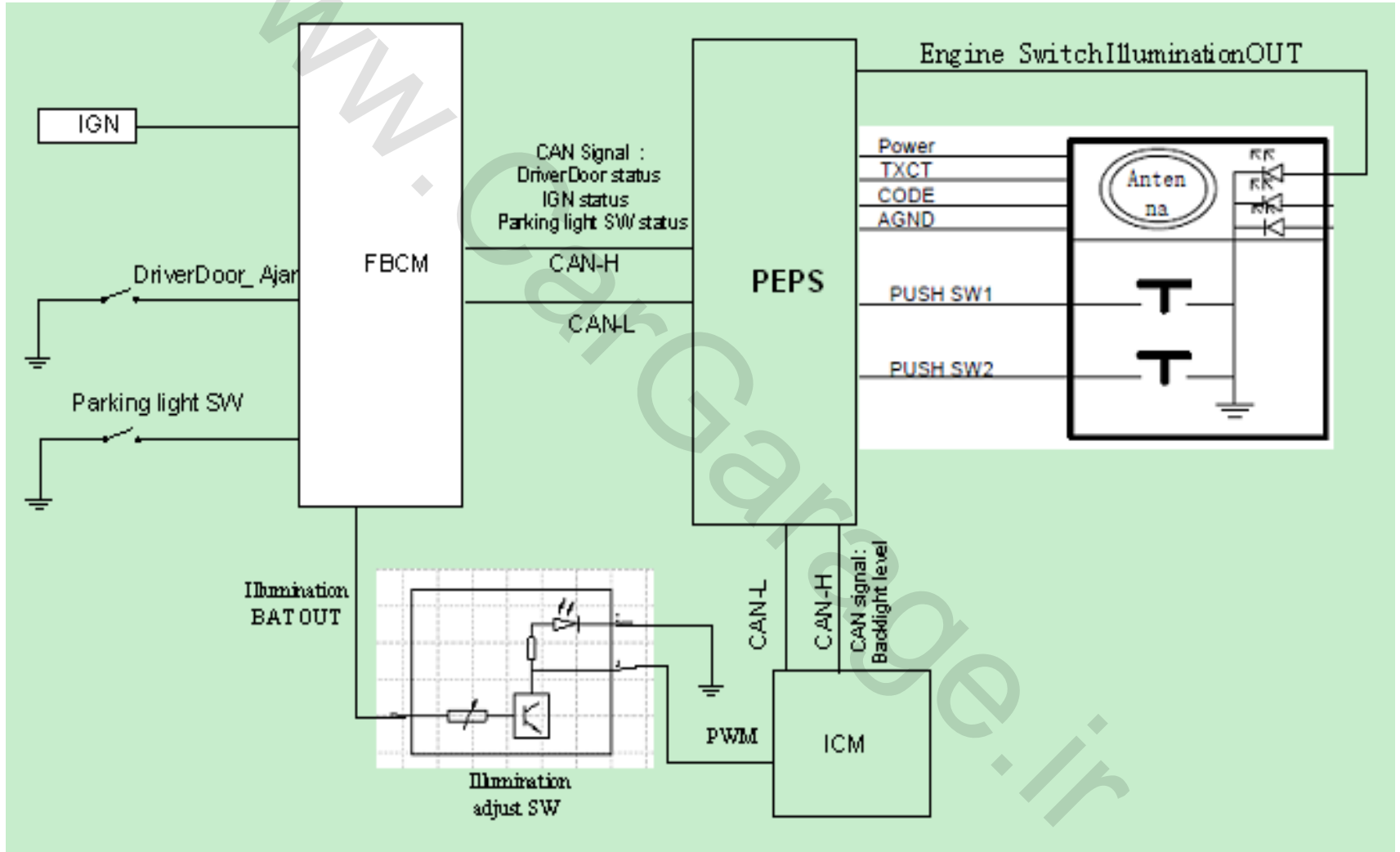

2. Function description

Speedometer

- Source of signal: CAN network
- Left/right front wheel speed sensor
- Arithmetic:
 - Two wheel speed sensors/2=vehicle speed;
- Vehicle speed signal output

Signal characteristics are listed below:

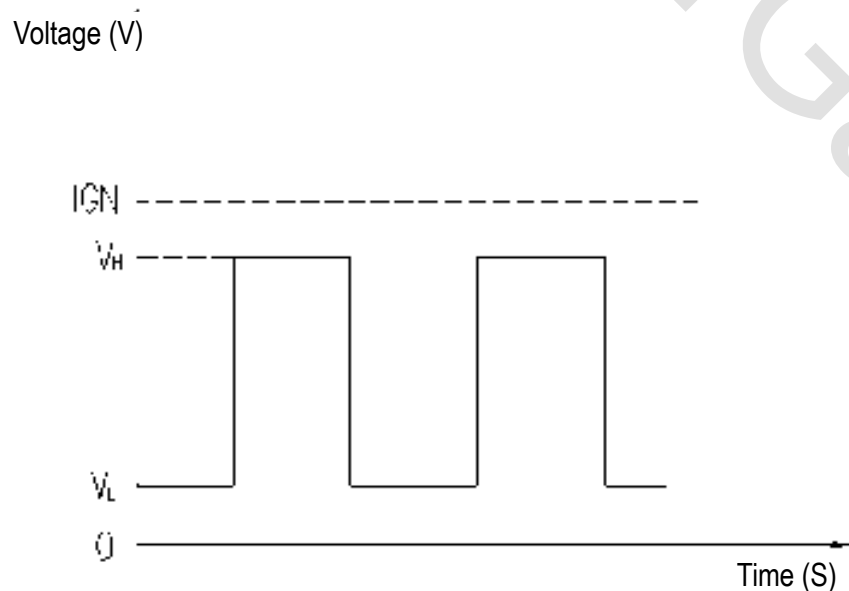

| Actual vehicle speed (km/h) | Indicated vehicle speed (km/h) |
|-----------------------------|--------------------------------|
| 0 | 0 |
| 20 | 20.6~23.1 |
| 40 | 41.2~43.7 |
| 60 | 61.8~64.3 |
| 80 | 82.4~84.9 |
| 100 | 103~105.5 |
| 120 | 123.6~126.1 |
| 140 | 144.2~146.7 |
| 160 | 164.8~167.3 |
| 180 | 185.4~187.9 |
| 200 | 206~208.5 |
| 214 | 220 |

2. Function description

Tachometer

- The tachometer is driven by the stepping motor, and the signal is transferred by CAN, with the signal source as follows:

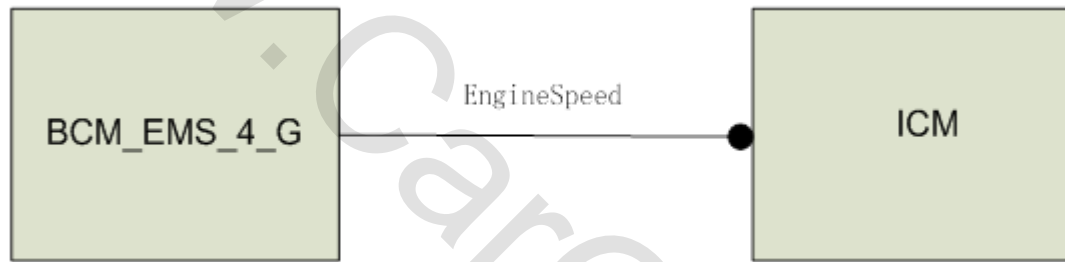

- Handling of revolution error
 - If the instrument fails to receive ECM CAN node revolution within 2.5s, the revolution pointer of the instrument cluster will stay at the current position;
 - 2.5s later, the revolution pointer will be zeroed.

2. Function description

Fuel gauge

- Fuel level sensor
 - The resistance corresponding to STOP_E is $300 \pm 6 \Omega$ and that corresponding to STOP_F is $36 \pm 2 \Omega$.
- Fuel level sensor parameters

| Pointer position | Volume (L) | Pointer error | Sensor resistance | Volume percentage (100%) | Send percentage |
|------------------|------------|-----------------|-------------------|--------------------------|-----------------|
| F-STOP | 55 | $\pm 1^\circ$ | 36 ± 2 | 100 | / |
| F | 50 | $\pm 1^\circ$ | 43 | 95 | 100% |
| 3/4 | 40 | $\pm 3^\circ$ | 62 ± 4 | 75 | 78.02% |
| 1/2 | 27.5 | $\pm 3^\circ$ | 89 ± 4 | 50 | 55.05% |
| 1/4 | 15 | $\pm 3^\circ$ | 137 ± 5 | 25 | 23.08% |
| Warning point | 11 | $\pm 1.5^\circ$ | 189 ± 5 | 20 | 14.29% |

12. Instrument cluster

2. Function description

Left/turn signal lamp

Parking lamp

High beam lamp

DRL (reserved)

Front/rear fog lamp

The indicator signal comes from BCM_6 of CAN, with the send cycle of 20ms. As for details, refer to T21 CAN signal list.



2. Function description

Driver side safety belt indicator

The driver side safety belt indicator signal comes from the driver side safety belt buckle (pin 19).

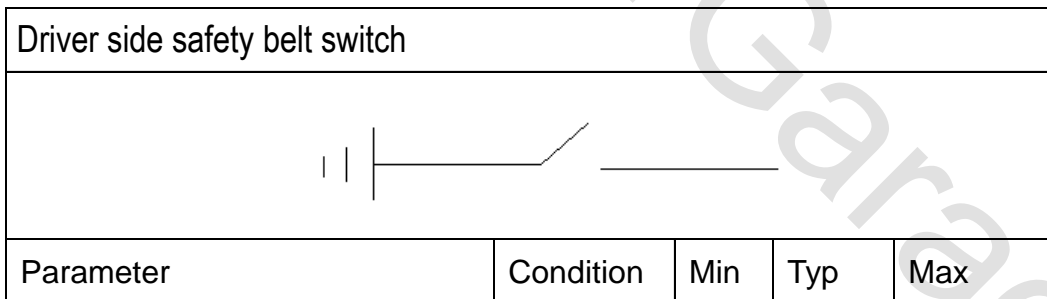

| Pin19) | Driver side safety belt indicator |
|-------------|-----------------------------------|
| Low voltage | ON |
| Open | OFF |

2. Function description

Driver side safety belt warning strategy

| | |
|--------------------------------|---|
| <p>With ignition key at ON</p> | <p>If the safety belt is fastened, the warning symbol on the instrument cluster will not be lit without buzz.</p> <p>If the belt is not fastened and the speed is $<25\text{km/h}$, the warning symbol will flash (500ms ON, 500ms off).</p> <p>If the speed is $\geq 25\text{km/h}$, the instrument cluster will buzz (500ms ON, 500ms OFF), and flash at the frequency with the warning symbol (500ms ON, 500ms OFF). This process will last for 100s. After the buzzing stops, if the belt remains unfastened, the warning symbol will flash (500ms ON, 500ms OFF).</p> <p>If the belt is unfastened in the operation: 1. When the speed is $<25\text{km/h}$, only the warning symbol will flash (500ms ON, 500ms OFF); 2. When the speed $\geq 25\text{km/h}$, the buzzer will work and the symbol will flash.</p> <p>Note: The speed refers to the actual vehicle speed.</p> |
|--------------------------------|---|

2. Function description

Warning deactivation

| | |
|--------------------------------|---|
| <p>With ignition key at ON</p> | <p>If safety belt is fastened, both the buzzer and indicator warnings will be stopped. With the engine stopped (the revolution is reduced to less than 300rpm from more than 300rpm), if the key is at ON, the buzzer will stop, while the indicator continues. If the key is at OFF, both buzzer and indicator will stop. At the reverse gear, or after the 100s warning, the buzzer will stop while the indicator continues.</p> |
| <p>With ignition key at ON</p> | <p>At reverse gear, or after 100s warning, the buzzer will stop while the indicator continues. If the gearshift lever is moved from reverse gear to forward gear and the safety belt remains unfastened, the buzzer will be triggered again. If the speed reaches 25km/h and the key is at ON, the safety belt warning will be also triggered. In the case of revolution CAN TIME-OUT (depending on specific code), the revolution will be zeroed [can]. Once the frequency signal is lost, the tachometer will be zeroed. After 100s indicator and buzzer warnings, if the engine is shut down, or the belt is fastened, or the reverse gear is engaged, it will work like: within one ignition cycle, the safety belt unfastened warning will be triggered only once.</p> |

2. Function description

Front passenger seat safety belt indicator

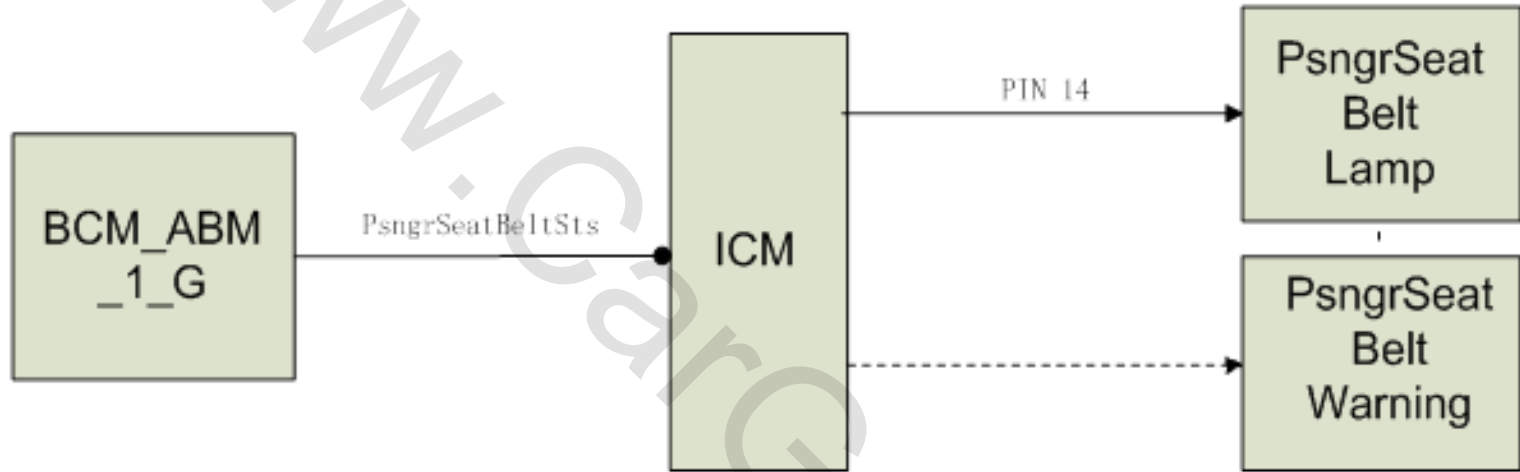

Front passenger safety belt input

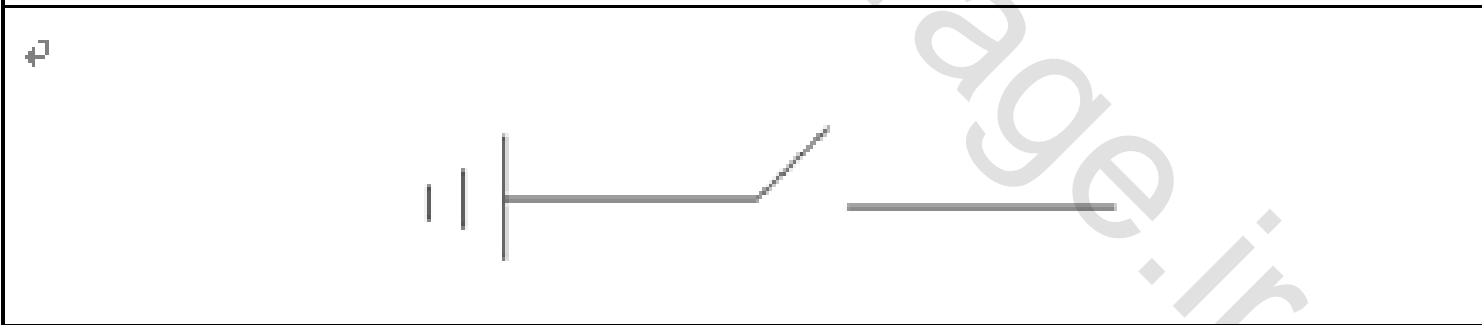

2. Function description

Front passenger seat safety belt output

The instrument cluster inputs a 0~1.5V voltage via PIN 14 to turn on the front passenger seat safety belt indicator lamp on the central console.

Warning activation

When the ignition key is located at ON:

If the safety belt is fastened or the seat is not occupied by an adult (depending on the signal given by the weight sensor), the passenger safety belt warning symbol will not be lit, without buzzing .

If the safety belt is not fastened and the vehicle speed is <25km/h, the passenger safety belt warning symbol will flash (500ms ON, 500ms OFF). When the detected speed is ≥ 25 km/h, the instrument cluster will start to buzz (500ms ON, 500ms OFF), with the warning symbol flashing synchronously (500ms ON, 500ms OFF). 100s later, the buzz will stop. If the safety belt remains unfastened, the warning indicator will flash (500ms ON, 500ms OFF).

When the safety belt is fastened but then it is unfastened during the driving operation: 1. If the speed is <25km/h, only the safety belt warning indicator on instrument cluster will flash (500ms On, 500ms OFF); 2. If the speed is ≥ 25 km/h, the buzzer will work and the warning indicator will flash concurrently.

Note: The speed refers to the actual speed.

2. Function description

Front passenger seat safety belt output

| | |
|----------------------|---|
| Warning deactivation | <p>If the safety belt is fastened, or the engine is shut down (the revolution is reduced to less than 300rpm from more than 300rpm; execute Note 3 of driver seat safety belt for revolution failure), or the reverse gear is engaged, or the passenger leaves the seat (the seat is provided with weight sensor), or after the 100s warning is over, both the buzzer and indicator will stop.</p> |
| Remarks | <p>If the safety belt is fastened, both the buzzer and indicator will stop. When the engine is stopped or the reverse gear is engaged, or after the 100s warning is over, only the buzzer stops while the indicator continues.</p> <p>If the reverse gear is engaged, the buzzer will stop while the indicator continues.</p> <p>If the gearshift lever is shifted from reverse gear to forward gear, and the belt is not fastened, the buzzer will be triggered again.</p> <p>After the 100s indicator and buzzer warning is over, if the engine is shut down, or the belt is fastened, or the reverse gear is engaged, the above 1), 2) and 3) apply.</p> |

12. Instrument cluster

2. Function description

High-configuration matrix LCD screen



| Display mode | Display zone | | |
|--------------|---|--|----------------|
| | A | B | C |
| Ordinary | For CVT vehicle, display transmission mode ("WINTER" or "SPORT"), outer temperature and overall information | Clock, ordinary information, trip computer information | Total distance |
| Instant | | Text of warning | |

12. Instrument cluster

2. Function description

Instant fuel consumption (IFC)

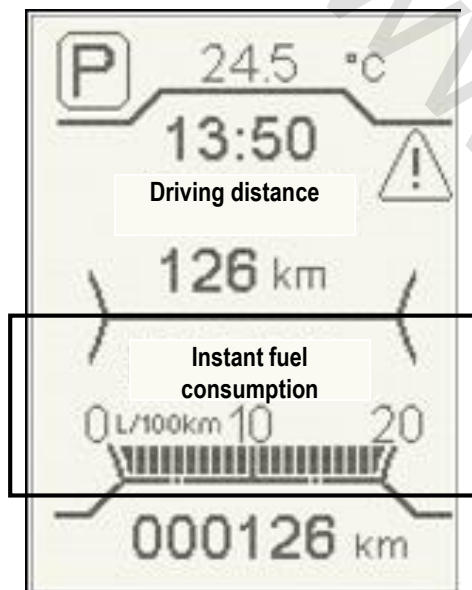

High-configuration matrix LCD screen

2. Function description

Instrument overall information display

- Audio & instrument information interaction

The communication and interaction between audio system and instrument system (high-configuration matrix LCD screen) are needed.

| No. | Displayed information | Instrument (matrix) | | Audio | | Instrument on-line configuration | Information transmission method | |
|-----|-----------------------|---------------------|-------------------------------|---------|---------|----------------------------------|---------------------------------|-----|
| | | Display | Steering wheel setting button | Display | Setting | | CAN | LIN |
| 1 | Radio frequency | ● | | ● | ● | | ● | |
| 2 | Search | ● | | ● | ● | | ● | |
| 3 | Mode | ● | | ● | ● | | ● | |
| 4 | Sound volume | ● | | ● | ● | | ● | |
| 5 | Language setting | ● | | ● | ● | ● | ● | |
| 6 | Speed limit setting | ● | ● | ● | ● | | ● | |
| 7 | Time setting | ● | ● | | ● | | ● | |

2. Function description

Time setting

- Via steering wheel button
- No disc DVD touch screen

Set the instrument cluster time, hour and minute, and transfer the settings via bus.
Set the instrument time via the steering wheel button.

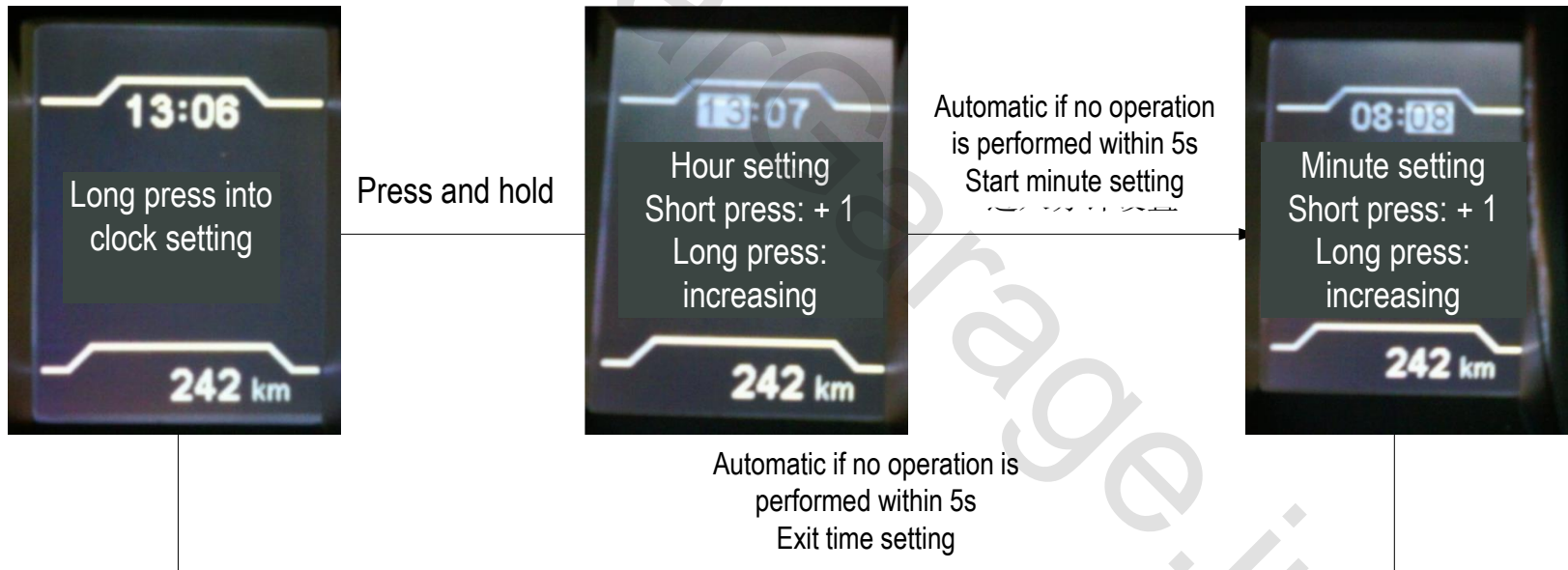

2. Function description

Display priority level

If the instrument receives signals from both DVD and steering wheel button at the same time, the signal from steering wheel will be shielded, while the CAN signal from DVD will be adopted.

[Radio frequency, mode and volume], outer temperature and SPT mode will be displayed on the audio information zone on the instrument. The priority level is as follows: SPT mode, [Volume/Mode/Radio frequency] (depending on the audio signal display) and outer temperature. They will not be indicated in a cycle; namely, the information of a lower priority level will be covered by the one of a higher level.]

2. Function description

“Follow me home” display

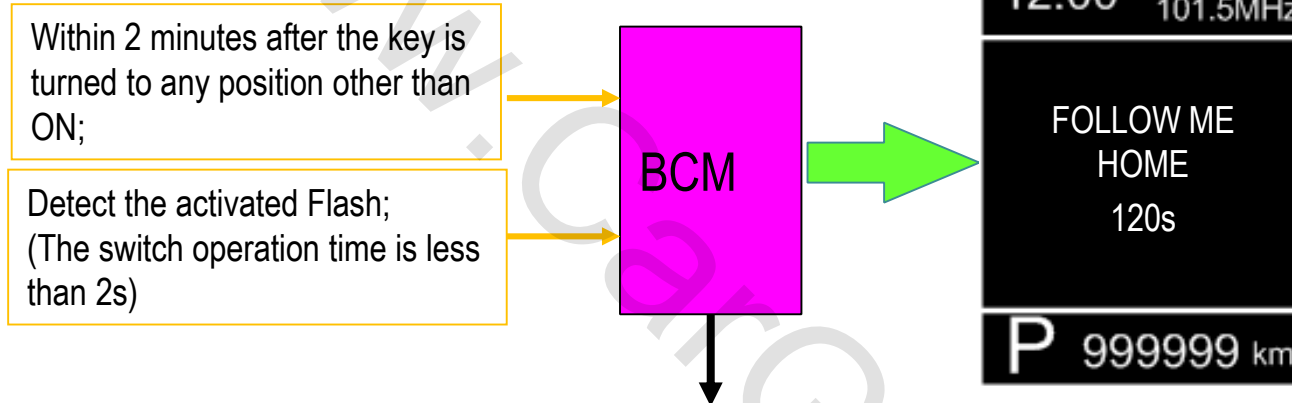

At this moment, BCM will activate FOLLOW ME HOME (low beam lamp, license plate lamp and side lamp will be lit).

FOLLOW ME HOME will keep valid for 30s each time it is activated (the low beam lamp, license plate lamp and parking lamp will be lit for 30s).

Within the valid time of FOLLOW ME HOME, low beam lamp=1; if FOLLOW ME HOME is deactivated, Low Beam Sts (low beam lamp) =0.

2. Function description

Activation of FOLLOW ME HOME

- 1. When signals detected by the instrument cluster meet following conditions

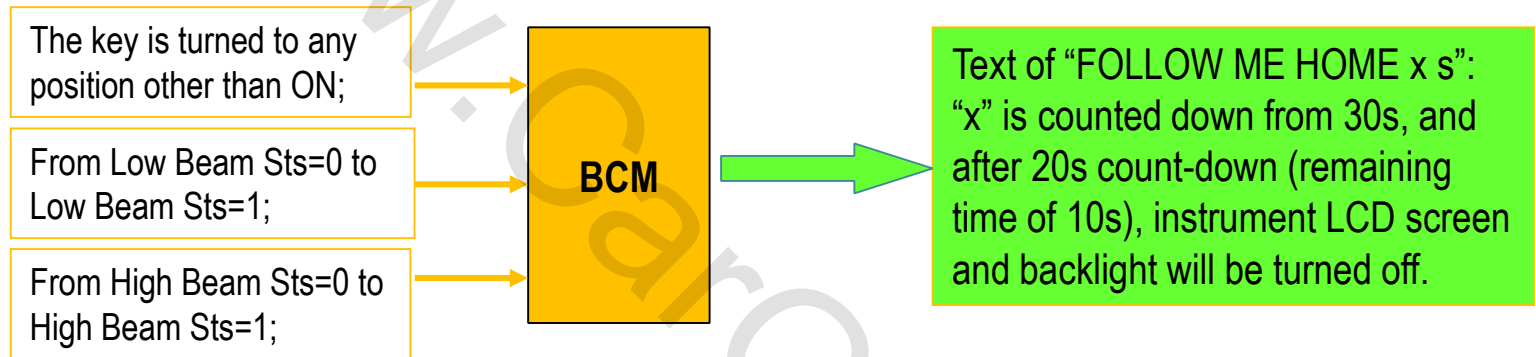

Instrument cluster LCD screen display

2. Function description

Activation of FOLLOW ME HOME

- 2. When signals detected by the instrument cluster meet following conditions

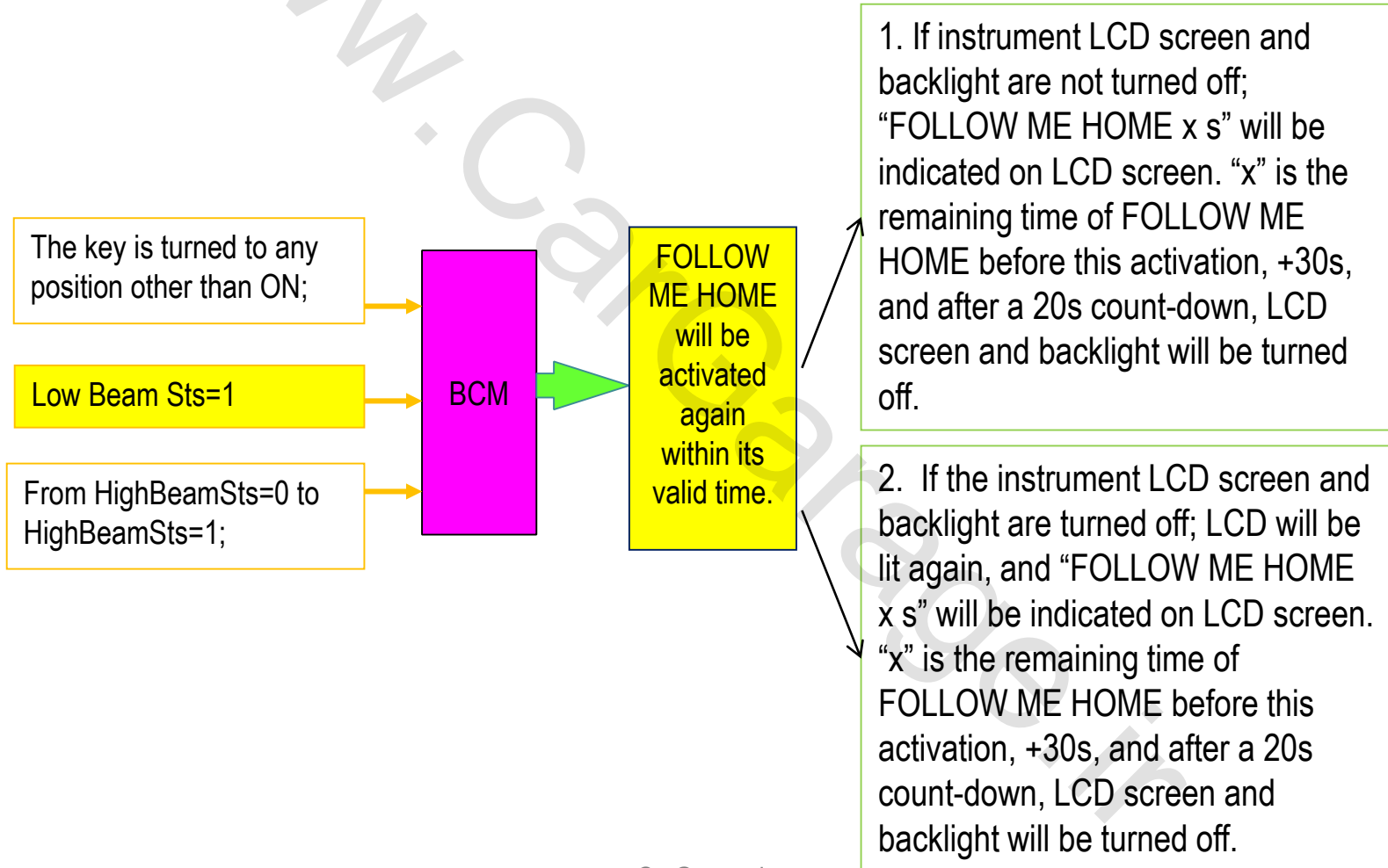

2. Function description

Trip mileage and total mileage

- Refreshing time
 - The trip mileage on LCD screen will be refreshed every 0.1km traveled, with the calculation cycle of 1s.
 - The total mileage on LCD screen will be refreshed every km traveled, with the calculation cycle of 1s.
- Display range
 - Range of trip mileage: 0.0~999.9km; in excess of 999.9 km, the mileage will be zeroed.
 - Range of total mileage: 0-999999 km; in excess of 999999km, this value will maintain unchanged.
- Zeroing method
 - Trip mileage 1
 - Press and hold SET in the trip computer 1 mode;
 - Maintain at D2/D3 for more than 2h (D2/D3 power mode IGN OFF mode)
 - In D4 mode, the trip mileage will not be stored.
 - Trip mileage 2
 - Press and hold SET in the trip computer 2 mode

2. Function description

Trip mileage and total mileage

– Zeroing method (Cont.)

- When and only when the total mileage firstly doesn't exceed 256km, press and hold SET in D4 mode, and ICM will enter D2 mode and last for 20s. The total mileage can be zeroed only once.

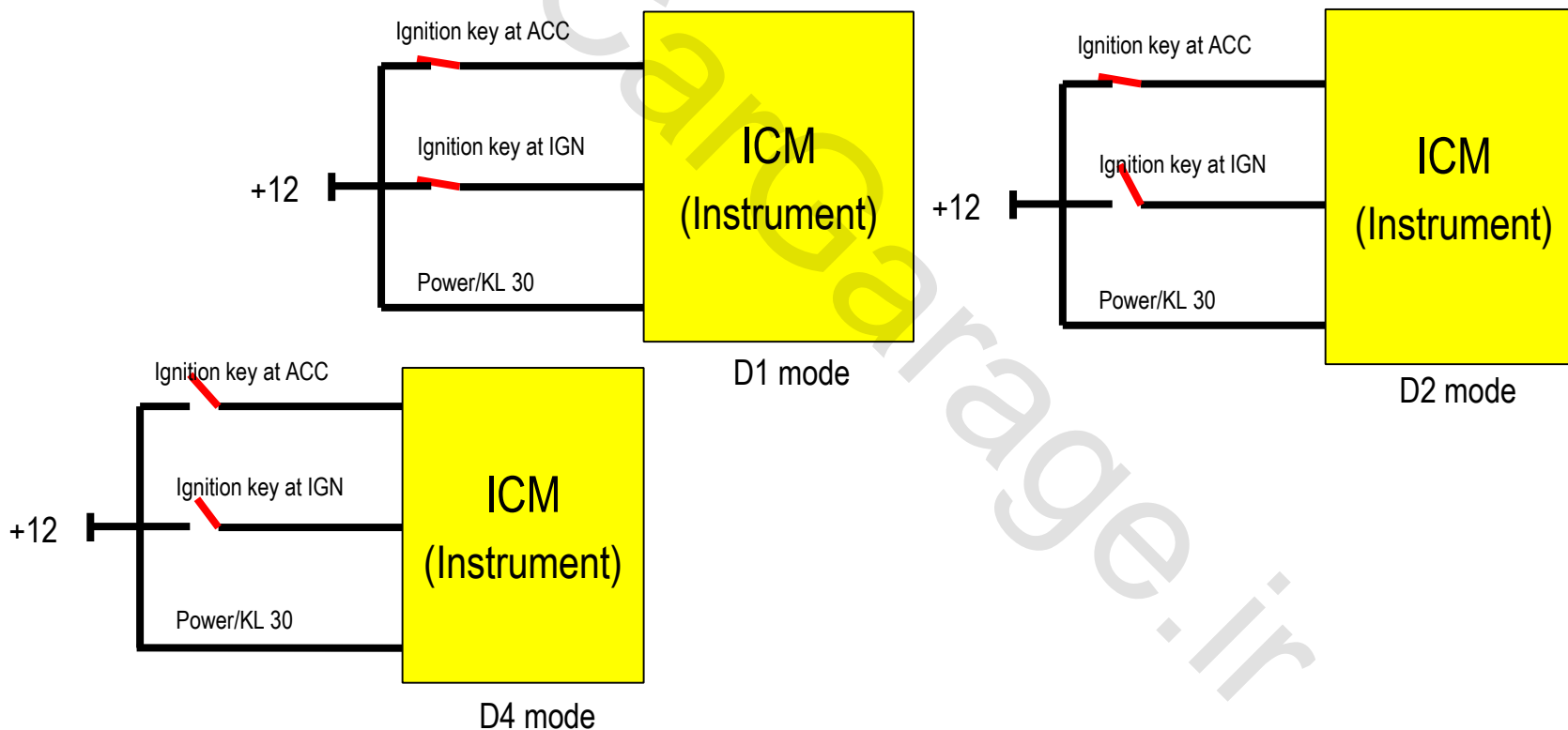

2. Function description

Instant fuel consumption

- Working conditions
 - Instant Fuel Consumption works under D1 conditions
- Refreshing time
 - The display on matrix LCD screen is refreshed every 50ms
 - The display on segment LCD screen is refreshed every 2s.
- Display range
 - 0~20L/100km; when the calculated value is greater than 20L/100km, 20L/100km will be displayed.

2. Function description

Instant fuel consumption

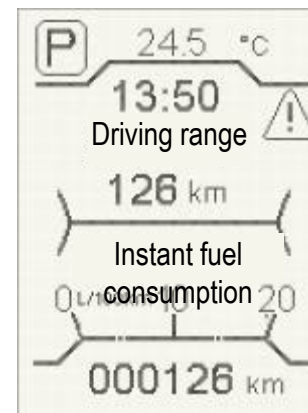
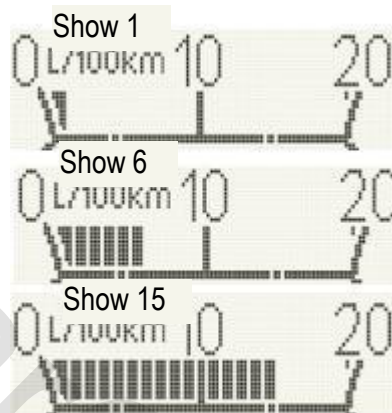
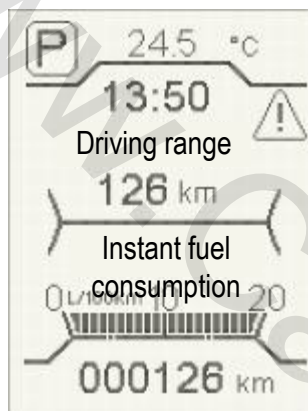

Display method and requirements

When the speed $V \geq 3 \text{ km/h}$, the instant fuel consumption will be indicated in L/100km; when $V < 3 \text{ km/h}$, it will be indicated in L/h.

At startup, the instant consumption shall be indicated quickly.

At acceleration, the instant consumption shall respond quickly.

The instant fuel consumption can't be memorized.

The minimum graduation is 1 L/100km, and the consumption is indicated in the rounded value on the chart.

If the instant fuel consumption is 0, no indication by graduation is available.

2. Function description

Source of instant fuel consumption

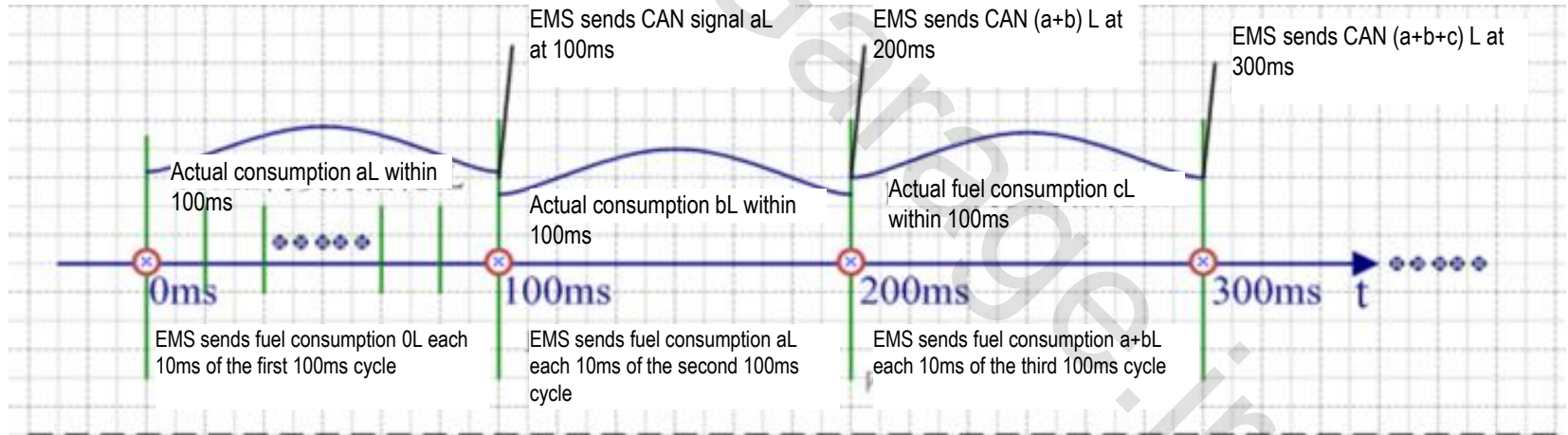
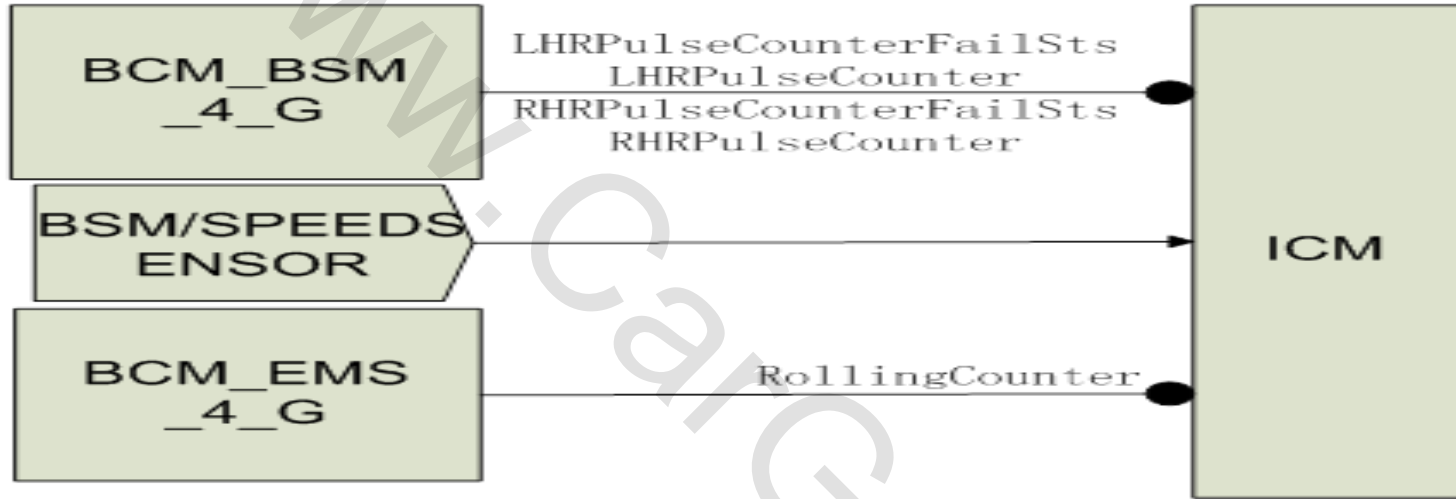

Note: When the accumulated value of EMS fuel consumption counter exceeds the threshold 0.020028382L, EMS will send (Counter-0.020028382) L as the initial value of another accumulation cycle, and so on.

2. Function description

Instant fuel consumption

| | |
|-----------------|--|
| Refreshing time | The instant fuel consumption is refreshed every 2s, with the calculation cycle of $T=1s$. |
| Display range | 0~20L/100km; when the calculated value is greater than 20L/100km, 20L/100km will be displayed. |

2. Function description

Average fuel consumption

- Zeroing method
 - Average fuel consumption 1
 - Press and hold SET in the trip computer 1 mode
 - Maintain at D2/D3 for more than 2h
 - In D4 mode, the average fuel consumption will not be stored
 - Average fuel consumption 2
 - Press and hold SET in the trip computer 1 mode
 - Display method
 - In D1 mode and with engine not started, the average fuel consumption will be indicated as the current value.
 - With the engine started and the speed at zero, continue calculation with the fuel consumption used to calculate the average fuel consumption.
 - Method of display of average fuel consumption after zeroing: “--.- L/100km” displayed for the first 100m.

Share the same source of instant fuel consumption. The average fuel consumption is valid in D1 mode

2. Function description

Driving range

- Display method
 - DTE (Data terminal equipment) has a display precision of 1km; namely, DTE is a multiple of 1km.
- Refreshing time
 - Refreshed every 10s; each 1km the car travels, DTE will carry out a calculation.
- Maintenance reminder
 - Maintenance distance zeroing

The maintenance distance can't be lost due to power interruption. It can be zeroed by either of two ways:

 - 1) Manual clearance: In D2/D3 mode, press and hold SET, and then KEY ON; namely, maintain the instrument for 5s in D1 mode;
 - 2) Via the diagnostic apparatus.

The driving range signal comes from BCM_BSM_4_G, BCM_ESM_4_G, Pin27 frequency signal and pin 21 fuel sensor resistance signal input. The driving range display is valid in D1 mode.

2. Function description

Circuit diagram of ICM

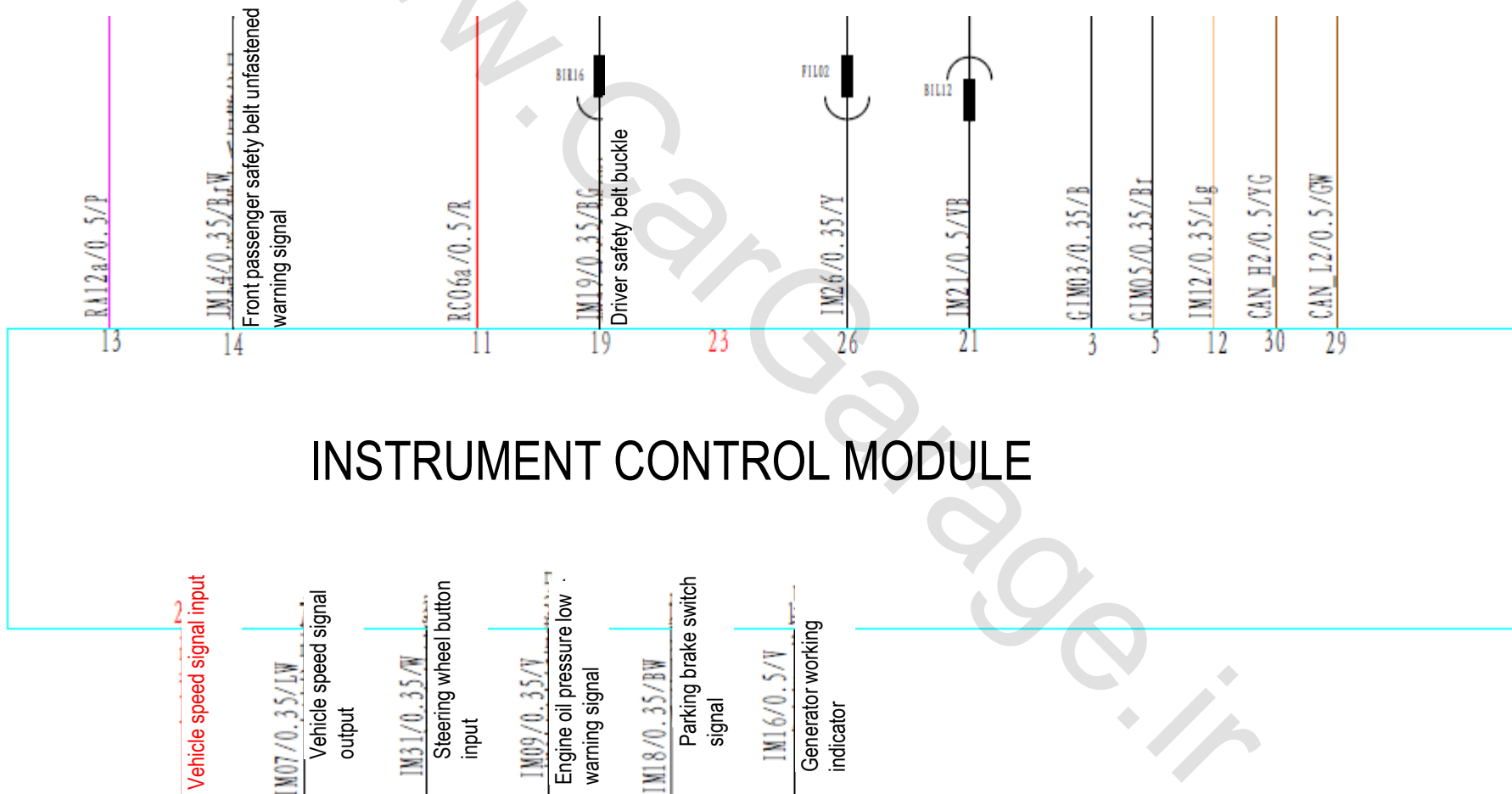



Audio system

1. General description

13. Audio system

1. General description

T21 audio & entertainment system consists of audio control module, touch screen, navigation module and so on.

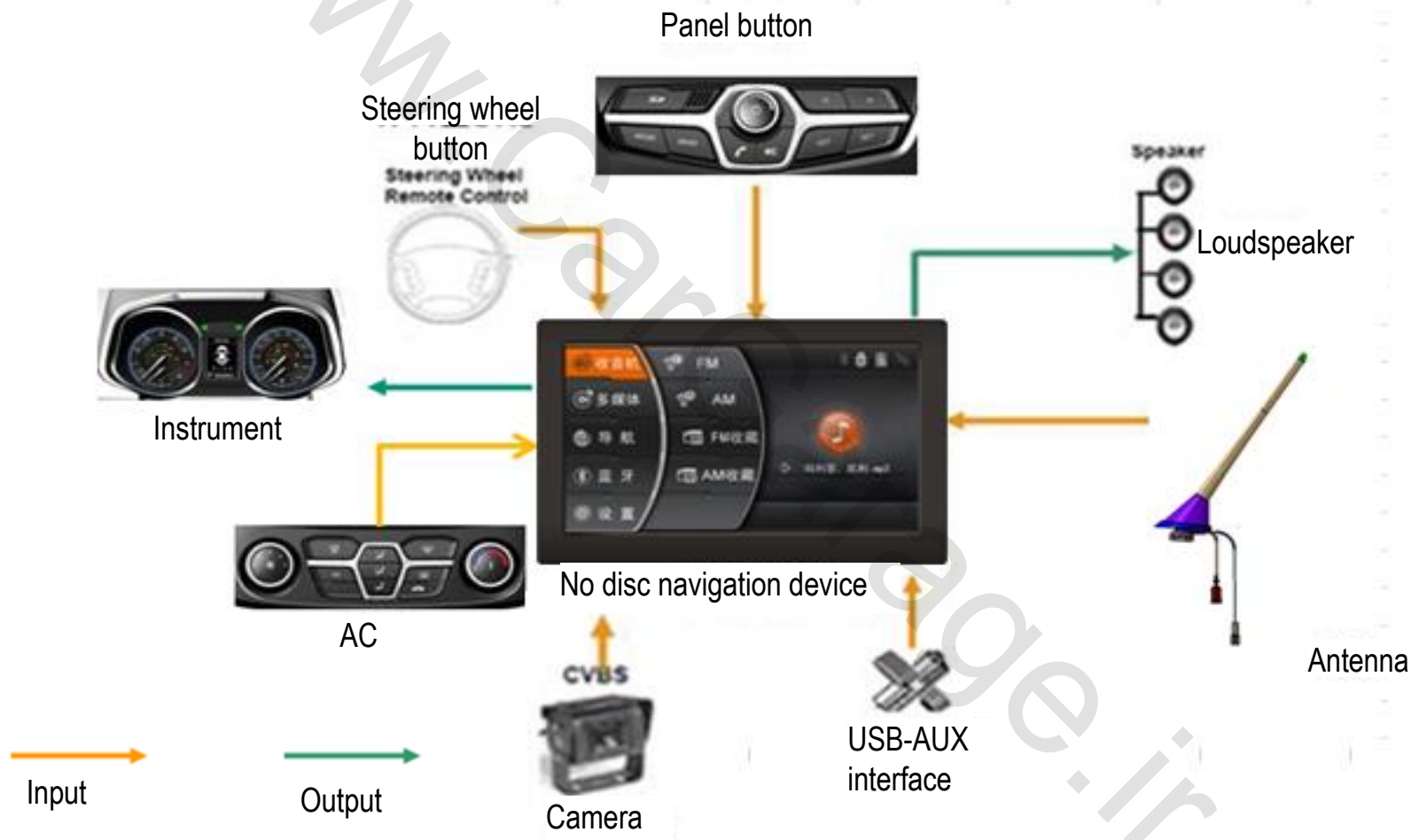





13. Audio system

1. General description

Definition of buttons on no disc DVD navigation control panel



| No. | Button | Function | Working range |
|-----|--|----------------------------------|--|
| 1 |  | System mute | Mute when FM, AM or AUX is being played; paused when USB is connected |
| 2 | BAND | Wave band switchover | FM1, FM2, FM3, AM1 and AM2 can be switched in a cycle. In other play modes, the system will be switched to radio mode. |
| 3 |  | Auto tune | In radio mode, press this button to search effective station of the previous band; |
| | | Manual tune | In radio mode, press this button, and move up forward by a step; |
| | | Track select | In MP3 mode, press this button to select the previous title; |
| 4 |  | Auto tune | In radio mode, press this button to automatically search the effective station of the next wave band; |
| | | Manual tune | In radio mode, press this button, and move down forward by a step; |
| | | Track select | In MP3 mode, press this button to select the next title; |
| 5 |  | Bluetooth | Enter Bluetooth mode; When there is a coming call, press this button to answer the call; press and hold it to reject the call. |
| 6 |  | System ON/OFF | Press the button to turn on or off the device; |
| | | Volume control | Rotate the knob to control the sound volume. To increase the volume, rotate it clockwise; to reduce the volume, rotate it counterclockwise. |
| 7 | MENU | Main interface information | Press this button to access main interface of audio system. |
| 8 | NAVI | Navigation interface information | Press this button to access the navigation interface (After the access to the main interface, a dialogue box will pop up. Enter the destination, and a selectable item will be added: no further |
| 9 | SET | Set | Switch to the overall setting interface including car information setting, sound effect setting, balance setting, instrument time setting, background setting |

1. General description

Main interface

Access the main interface by sliding on the HMI interface; at this moment, the cursor focuses on the current program mode of primary menu. Select the primary menu on the touch screen, and then the secondary menu will be displayed immediately.



13. Audio system

1. General description

There are four options on the radio interface: FM storage list, AM storage list, Radio interface FM, AM. After the cursor enters the secondary menu of radio interface, operate on the touch screen.

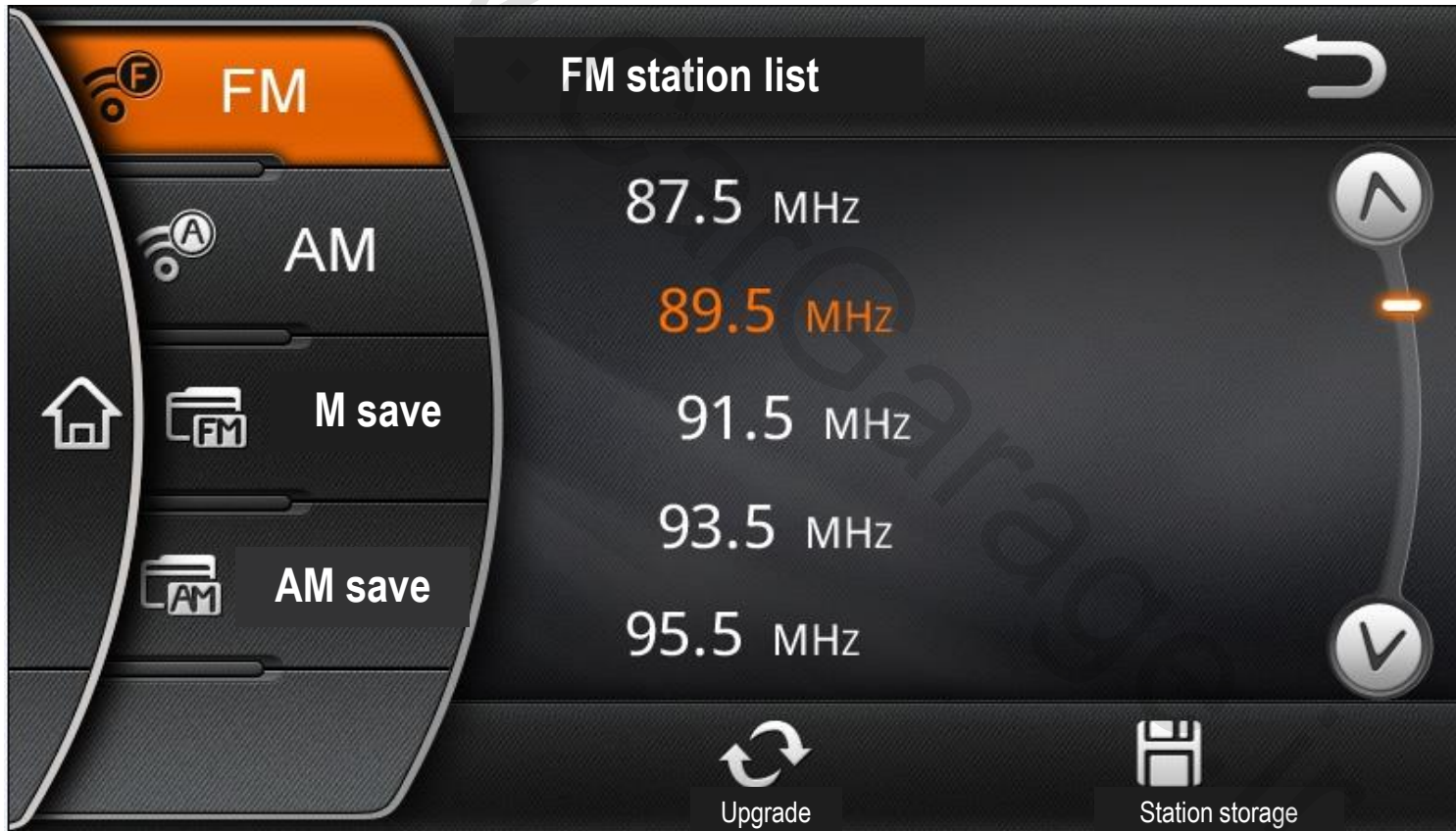

13. Audio system

1. General description

Multi-media interface Access SD, USB and AUX interface via the multi-media interface. If the corresponding play medium is not present, the menu applied will be turned grey. If these three media are all not present, "No play medium" will be indicated on the interface.



13. Audio system

1. General description

Bluetooth interface Bluetooth interface has 6 secondary menus: Bluetooth switch, Search Bluetooth device, Phonebook, Phone, Bluetooth music



1. General description

| | |
|----------------------------|--|
| Bluetooth switch | This function can be used to turn on or off Bluetooth device. |
| Search Bluetooth device | Click "Search Bluetooth device", and the device starts to search the surrounding Bluetooth device. Searched Bluetooth devices will be listed. At this moment, select the device to be connected and start connecting. Identification of automobile Bluetooth: Tiggo5 XX:XX:XX, password: 0000. At most 8 phones can be allocated for the Bluetooth device. |
| Phonebook and text message | After Bluetooth device is connected to the cell phone, click Phonebook, and the downloader will prompt you whether to download Phonebook. If yes, the device will download Phonebook from the cell phone; if no, the device will not download. When the phone is returned in the matching range of the onboard device Bluetooth, the cell phone Bluetooth will be matched automatically. After the Bluetooth cell phone matching the onboard device receives any message, the onboard device will give a prompt sound. |

1. General description

Click “Phone” to directly dial the phone number or access the phonebook for direct dial. In the course of conversation, if the car starts reversing, the display interface will be switched to reversing image. In this process, the conversation will be Phone maintained. The conversation can be switched to the cell phone, and after the conversation, the matching will be automatically recovered. During conversation, Bluetooth device will be disconnected and the conversation is switched to cell phone; when Bluetooth device is turned off, all devices will be disconnected.

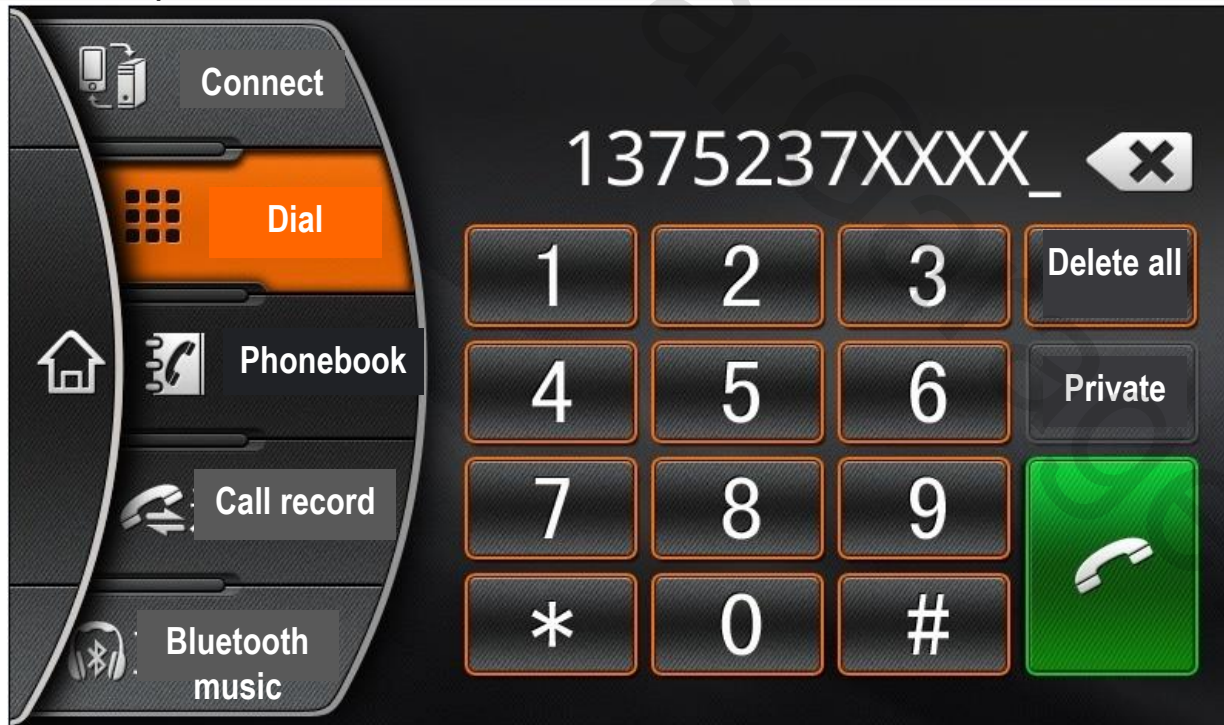

1. General description

USB charger

The current range is 550mA-1,000mA to adapt to mainstream cell phones. The USB charger circuit is designed to have an appropriate current size, and a 1.5A power current limiting circuit is additionally provided to ensure the steady output. This USB interface can be also used to drive a 32G or above mobile hard disk.

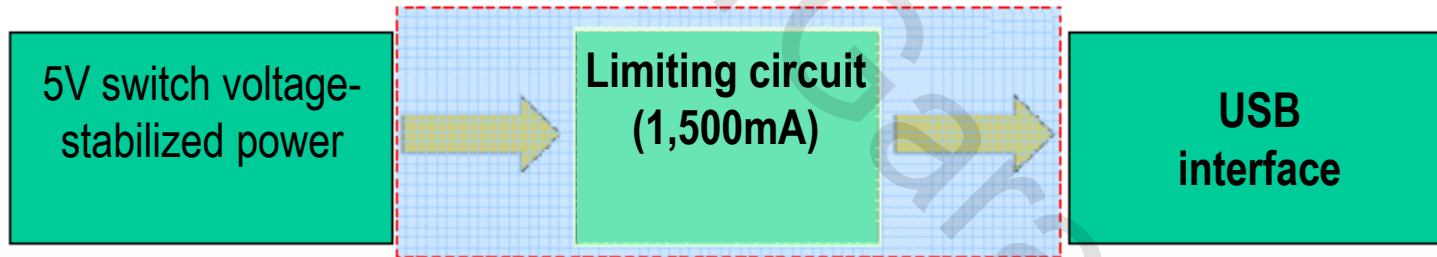

1. General description

Activation
of
no disc
navigation

1. Only when BAT is charged, the system will be controlled via internal logic of the device. When the logic is set “ON”, the audio device can work for half of an hour when BAT is charged, and thereafter, the navigation system will be automatically stopped, and it can be switched on again via POWER SWITCH.
2. When both BAT and ACC are charged, the system can be activated via POWER SWITCH and work in a long period.
3. When ACC is charged and R gear signal is valid, the system will be activated automatically.
4. When Bluetooth device is connected and the key is at ACC, upon the receipt of the incoming call from the connected phone, the system will be activated automatically.
5. When ACC is charged and AC signal is received, the screen will be lit and if the AC is not operated within 5s and the navigation device is not activated, the screen will be off.
6. Upon the receipt of trigger conditions, relevant symbols will be indicated within 0.5s, and the sound output will be made within 2s.

13. Audio system

1. General description

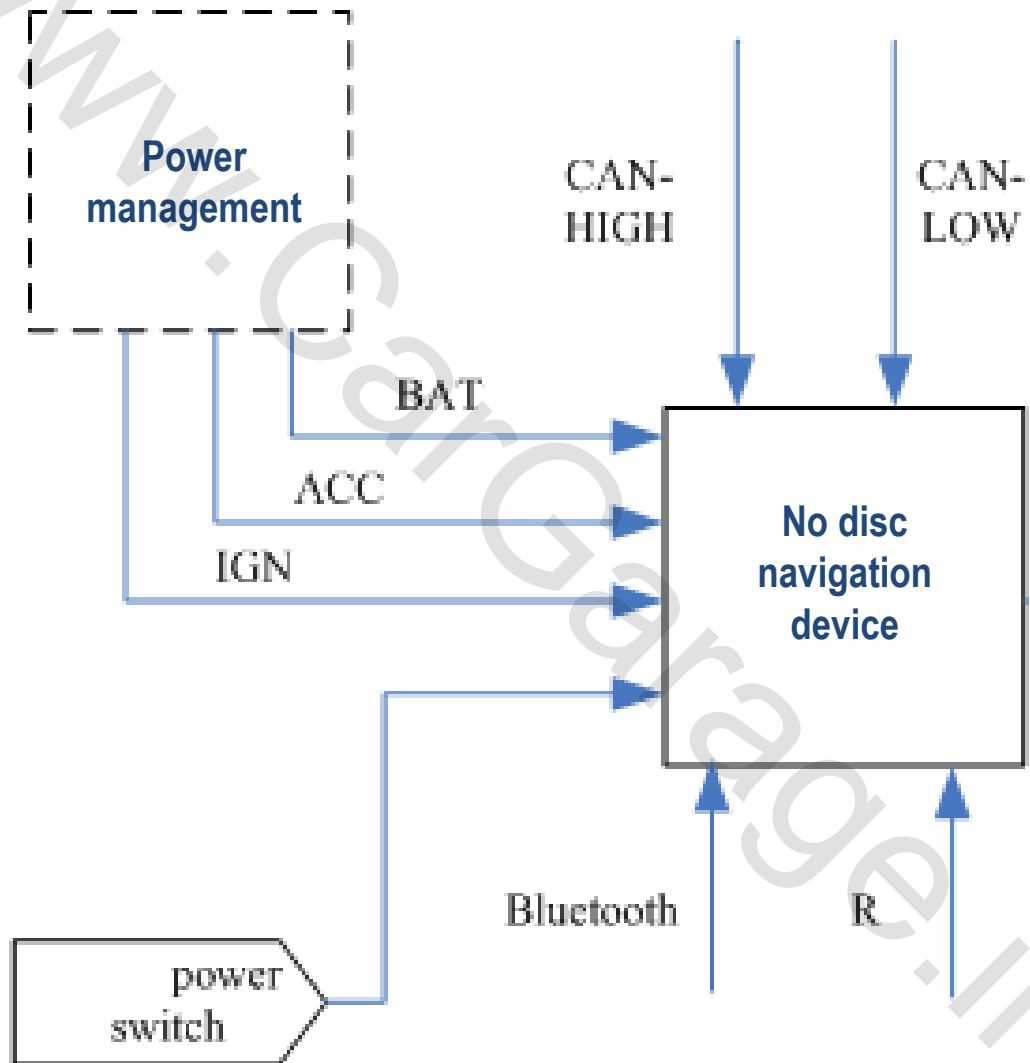

1. General description

Language setting

Function: The language of HMI (no disc DVD screen, instrument screen) can be switched between Chinese and English via DVD touch screen. The languages supported by audio system and instrument can be configured on the line. After the online configuration and 30 power supply disconnection, settings need to be stored.

Working conditions: The language setting is valid in D1 mode. In D3 mode, the setting can't be realized via DVD touch screen.

Text prompt on the screen: "Please turn ignition key to ON before setting car functions".

Input: The language can be switched between Chinese and English via DVD.

Method of realization: The language switching is realized by transferring Lag Set signal to the instrument cluster via CAN bus.

Output: The language switching is realized by instrument cluster.

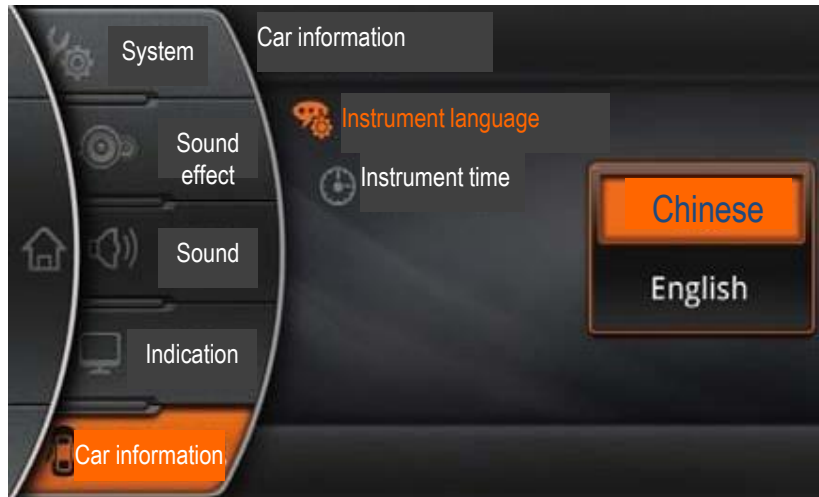

1. General description

Time setting
Function: The instrument time can be set by steering wheel button or DVD screen, including 12h/24h system, hour and minute. Setting information is transferred via bus.
Working conditions: Language setting is valid in D1 mode.
Input: 12h/24h system, hour/minute are set by steering wheel button or DVD screen.

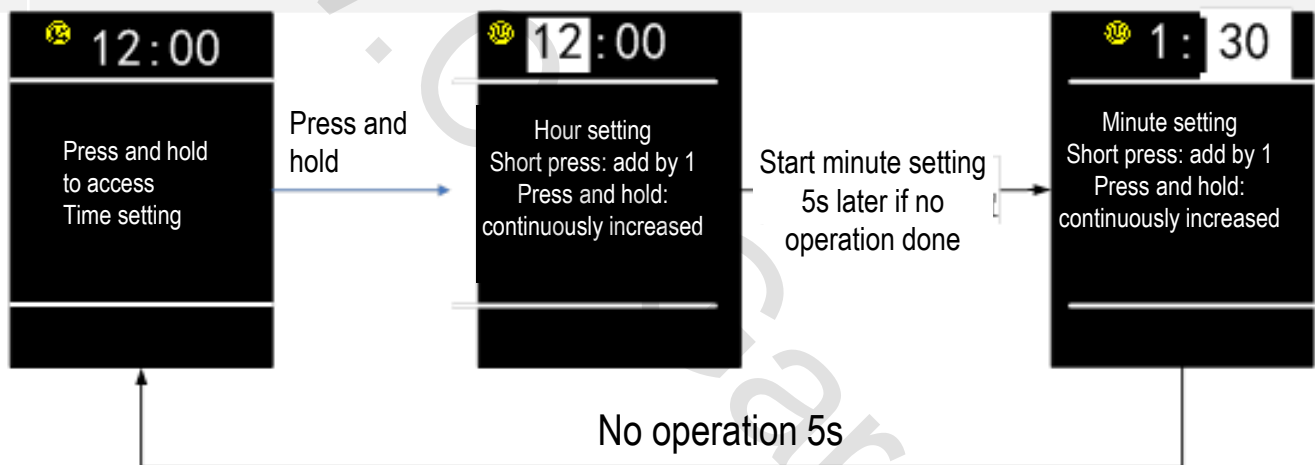

1. General description

Method of realization

Upon power-on of +15 line, the instrument will send the current time to the audio system to realize the time synchronization between instrument and audio system. Except for the current time display on the time setting interface, no time display is provided in the audio system.

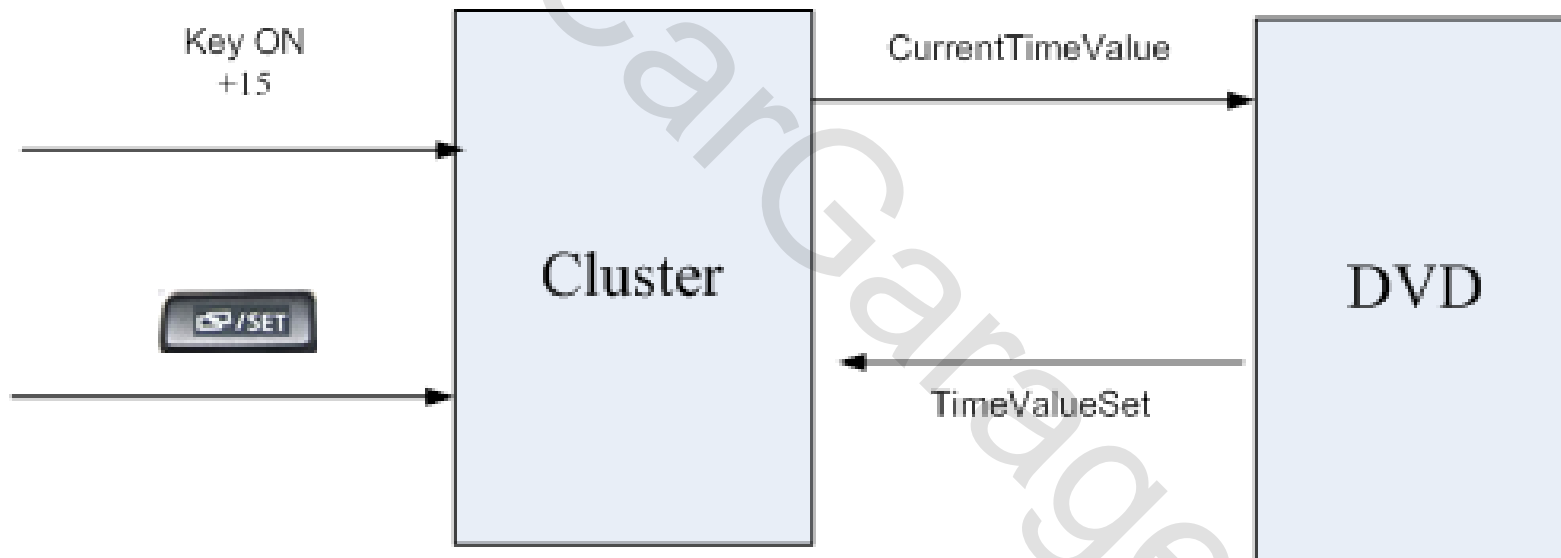



TELEMATICS system



I. Description on wireless communication

T-BOX is connected with the serial port of the onboard navigation device, and the cell phone Bluetooth is used as a channel to connect it to the TSP background

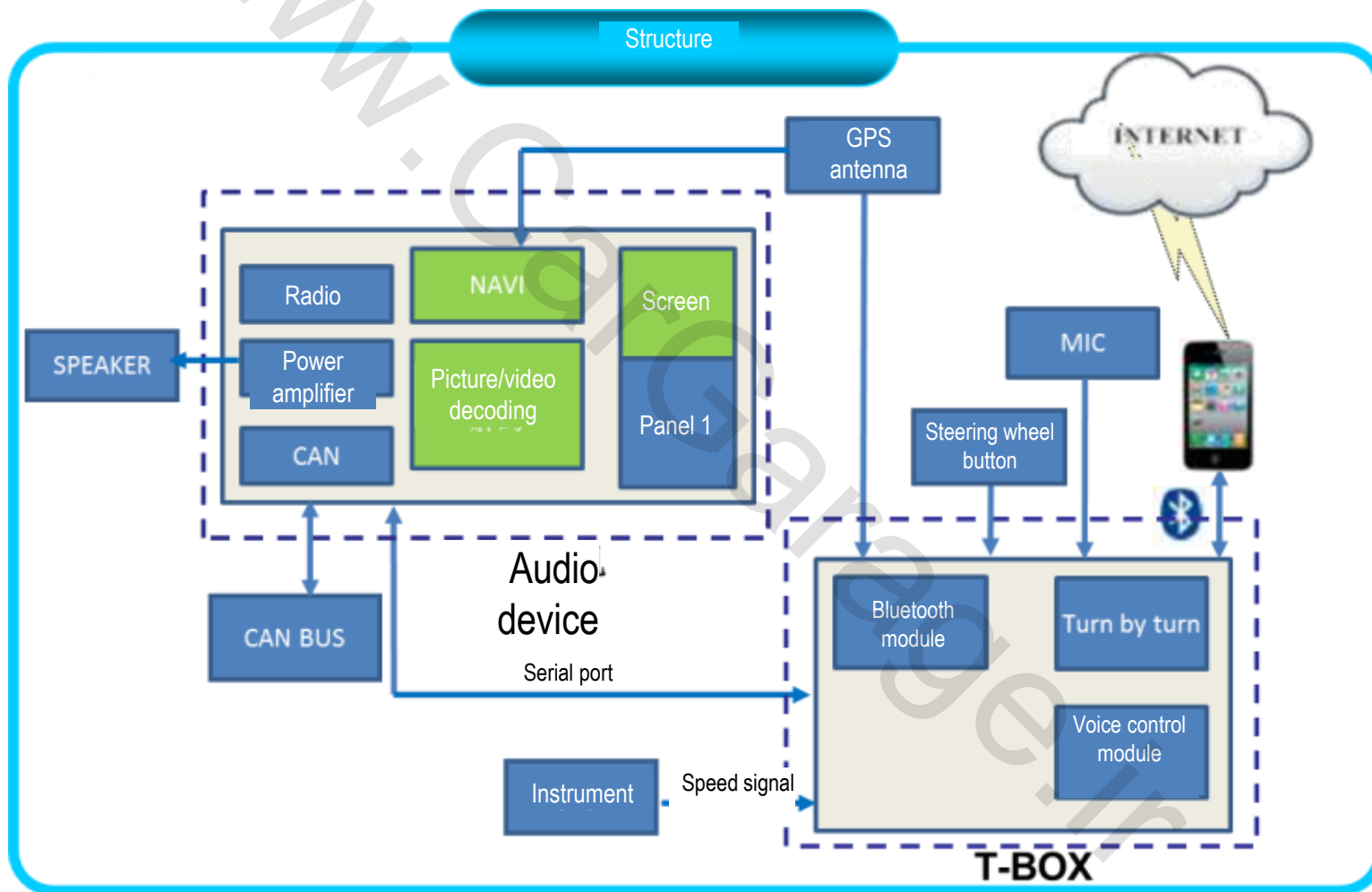

14. TELEMATICS system

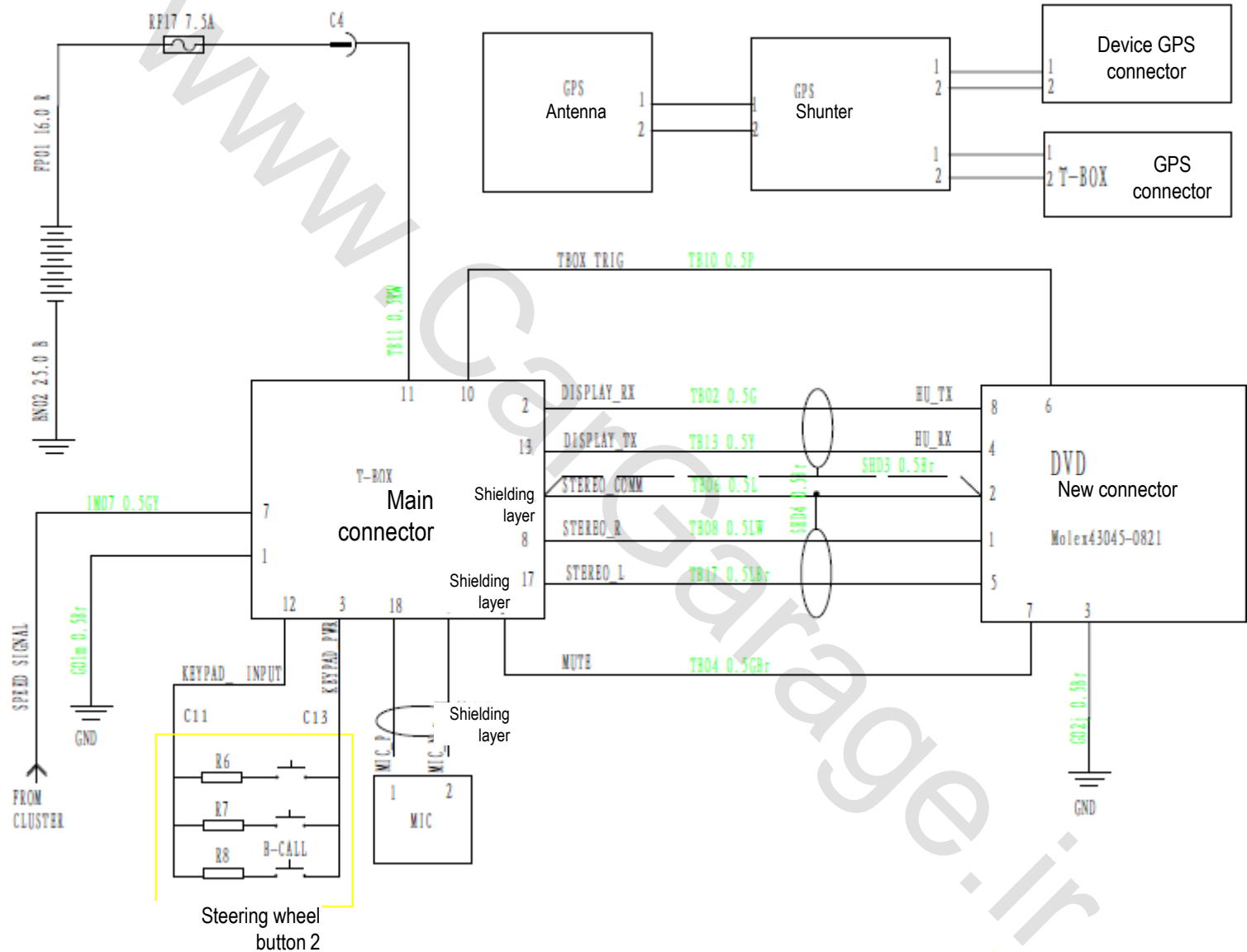

I. Technical solution

List of functions:

| Function | Sub-function | Description on functions |
|--|---------------------------|--|
| Road rescue B-CALL | / | When field rescue service is need, such as supply of water/gasoline, jump start, towing and tyre replacement, activate B-CALL service via Chery Net-Car onboard system, the system will automatically call the rescue center which will dispatch rescue organization depending on your demands and location. The rescue organization will then contact you and provide rescue service. |
| Car remote diagnosis | / | When you need to immediately know your car conditions, start the car remote diagnosis via the touch screen button. After the successful diagnosis service, you can view the diagnosis report in the onboard inbox. |
| Local navigation On-line navigation | Ordinary navigation | Ordinary map navigation: The onboard device uses locally stored map data for navigation. |
| | POI online search | When ordinary map navigation is used for POI search but fail to get desired POI information, it can access the latest POI information by POI online search. |
| | Network destination | You can add your interested POI into “Network destination” in “Owner network”. When you open the network destination in the onboard device, network destinations stored in the network will be indicated. |
| | Real-time road conditions | You can know the real-time road conditions via voice broadcast and text display, and also search the real-time conditions of the designated road in the voice manner. |

I. Technical solution

List of functions:

| Function | Sub-function | Description on functions |
|-----------------|-------------------------|---|
| Bluetooth music | / | You can access, play and control the cell phone music via Bluetooth: Previous/Next/Play/Stop. |
| TTS broadcast | / | By voice broadcast of text information by TTS, you can set certain information into manual or auto broadcast, including contact person, weather, news, navigation prompt, voice recognition prompt and coming call. |
| Weather | Local Weather | You can access the current car location and weather information of the current day and future two days via voice or touch screen. The weather information will be displayed on the screen of onboard navigation device. |
| | Weather of other cities | You can access the weather information of the designated city on the current day and in future two days via voice or touch screen. The weather information will be displayed on the screen of onboard navigation device. |
| News | / | The news and information of the designated category as selected via voice or touch screen will be displayed on the screen of onboard navigation device, and can be broadcast via voice. News categories include general news, international news, domestic news, social news, financial news, sports news and entertainment news. |

I. Technical solution

List of functions:

| Function | Sub-function | Description on functions |
|-----------------|---------------------------|---|
| Onboard inbox | / | Access "Onboard inbox" via voice order or touch screen to view the remote diagnosis report, and delete or clear designated entries on the touch screen. |
| Bluetooth phone | Phonebook synchronization | Automatically download the phonebook in the cell phone into T-BOX. When Bluetooth device is disconnected, the downloaded phonebook will be cleared. |
| | Answer the call | You can answer the incoming call via the steering wheel shortcut button or touch screen. |
| | Reject the call | You can reject any incoming call or interrupt the conversation via the steering wheel shortcut button or touch screen. |
| | Mic mute | Without necessarily rejecting the call during conversation, you can mute Net-Car system mike via voice or button, by which the callee can't hear your voice, but you can hear the callee's voice. |
| | Dial | You can read the phone number or name via the voice recognition system and dial the number, and dial the entered number via the touch screen, or dial the number in the phonebook. |
| | Redial | You can redial the last call-out number through the voice order or button. |

I. Technical solution

List of functions:

| Function | Sub-function | Description on functions |
|-----------------|--------------------------------|--|
| Bluetooth phone | Coming call broadcast | When your phone is connected to Net-car onboard Bluetooth device, the incoming call will be immediately broadcast and indicated on the onboard screen. If the synchronized phonebook contains the current incoming call number: the incoming call information comprises the name and phone number of the contact person; if the said number is not included, the incoming call information only comprises the call number. |
| | Call record | When your phone is connected to Net-car onboard Bluetooth device, the call record in the phone will be synchronously downloaded into onboard device. |
| | Private mode switch | During conversation with Bluetooth phone, you can switch between hands-free and private mode by touch screen button or steering wheel button. |
| | Uninterrupted call | When your phone Bluetooth device is activated and you move into the car by holding a conversation, after Net-car onboard system is started, the conversation will be automatically switched to Bluetooth mode. In the course of hands-free conversation, if you turn off or keep far from (10m) Net-car onboard system, the system will automatically switch the conversation to the cell phone. |
| | Cell phone low-battery warning | When your phone is connected to Net-car onboard Bluetooth device, if you phone battery is at low level, the low-battery warning will be given. |

2. Operation description

Operation of T21 wireless communication system:

Press wireless communication device power ON/OFF button, and this device will be started.



2. Operation description

Bluetooth match and connection

Click phone icon on main interface, and the Bluetooth match request dialogue box will pop up.

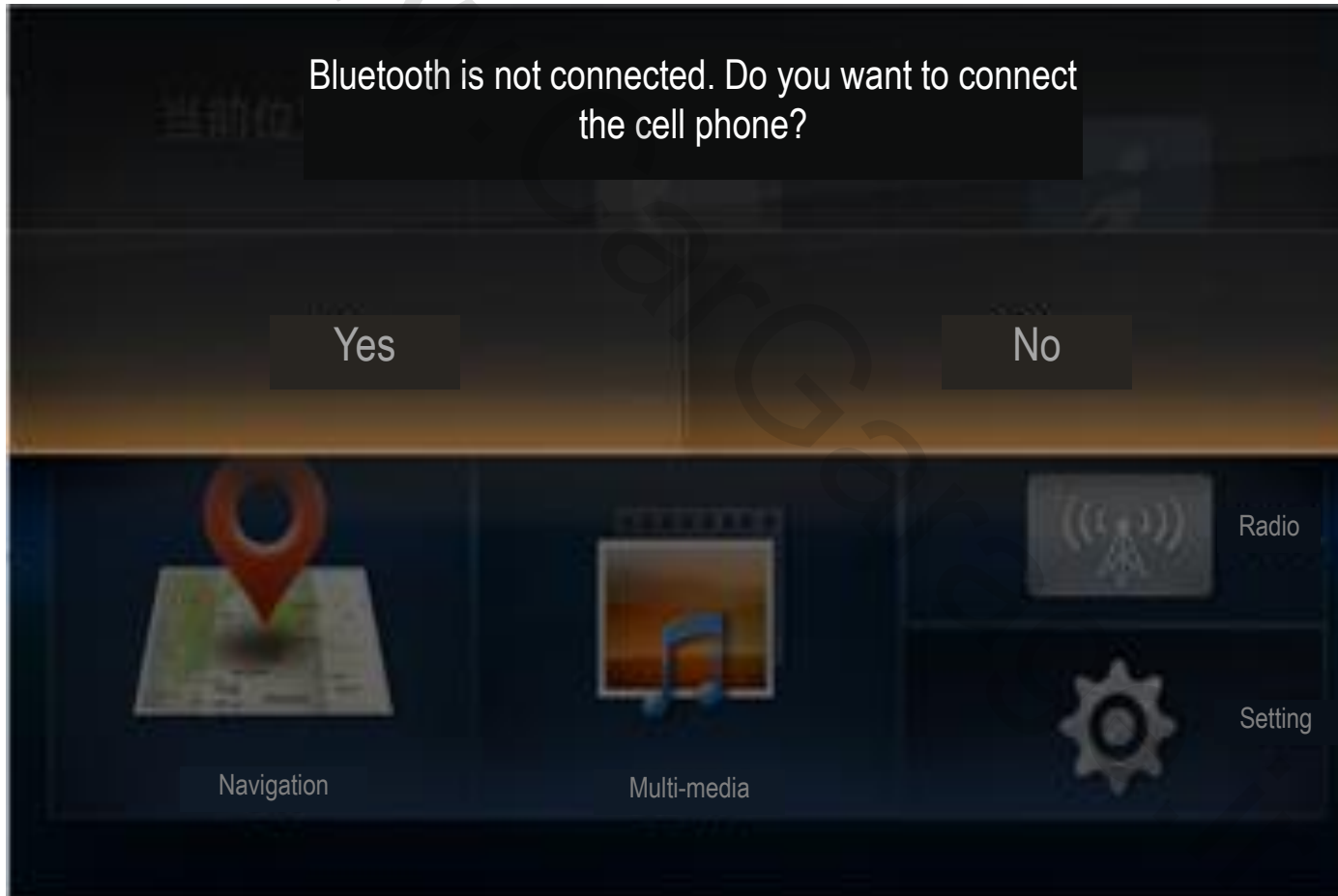

2. Operation description

Bluetooth match and connection

Bluetooth is not connected. Do you want to connect the cell phone?

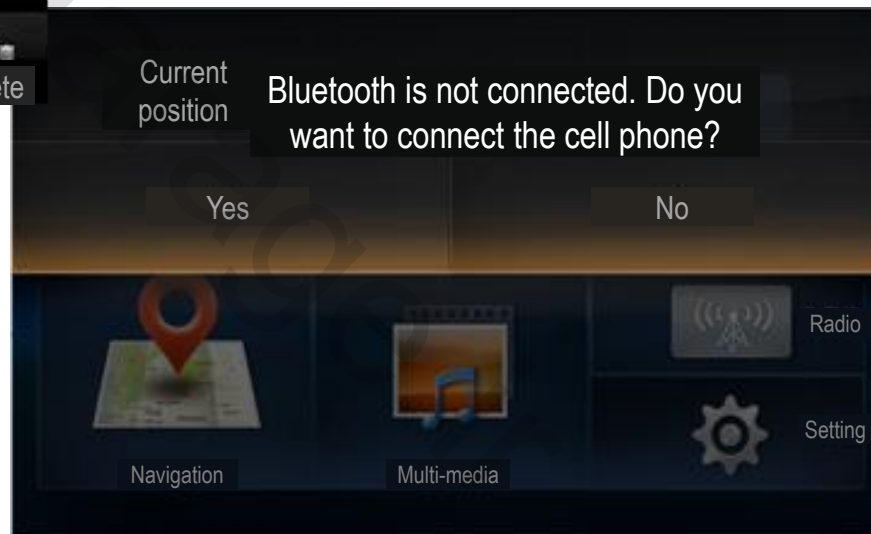
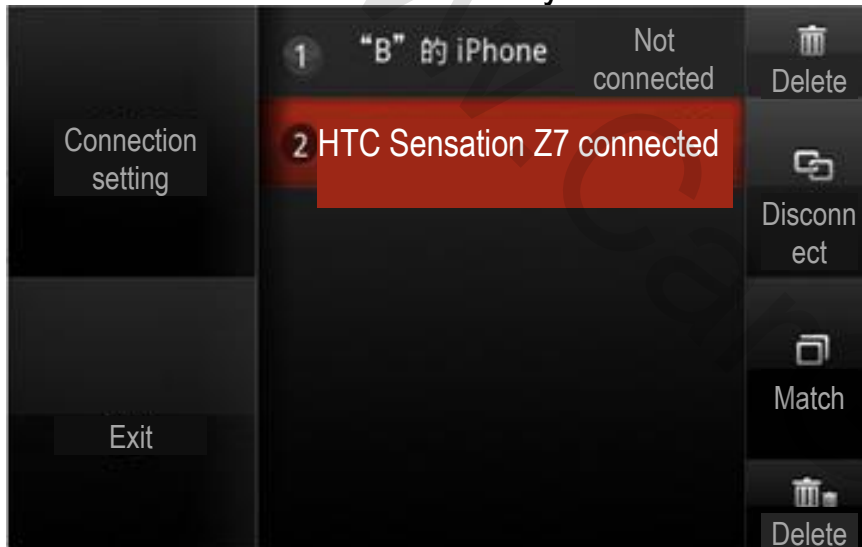

2. Operation description

Bluetooth phone

After Bluetooth matching is finished, you will access Bluetooth phone interface for Bluetooth dial, phonebook search, call record search, Bluetooth phone connection and road rescue.



2. Operation description

Click navigation icon on main interface or use voice order to access navigation interface. On the navigation interface, the map is displayed, and it can be zoomed in and out for you to search surrounding facilities, locations and destinations, to set the navigation route, control sound volume and view Start search information.



2. Operation description

Information function

Click the information icon on main interface or use voice order to access the information interface. After the successful connection of cell phone Bluetooth, please confirm that your phone network hot spot (GPRS or WiFi) has been connected. Only when your phone network is activated, following functions can be realized. Click the news icon or use the voice order to access the news browse interface (available news includes international news, general news, domestic news, social news, financial news, sports news, entertainment news). Click the weather icon or use the voice order to access the weather information interface to acquire weather information for future three days (inclusive of the current day) throughout the country. Click the traffic information icon or use the voice order to access the real-time traffic information interface to acquire real-time traffic information in Shanghai, Guangzhou, Shenzhen, Shenyang, Wuhan, Chengdu and Chongqing. Click the diagnosis icon to access the car fault diagnosis interface for fault diagnosis for these 6 major modules: EMS, TCM, BSM, ABM, EPS and PEPS. Click the inbox icon to access the inbox icon interface to view the fault diagnosis report which is sent back after it is decoded by the background.

2. Operation description

Operation interface of information function



2. Operation description

Radio

Click the radio icon on the main interface or use the voice order to access the radio interface. In the radio mode, following functions are available: FM/AM switchover, previous radio station/next radio station, step up/down, station search, station storage, station list refresh.



2. Operation description

Multi-media

Click the multi-media icon on the main interface to access the multi-media interface on which SD, USB/iPod, Bluetooth music (after the phone Bluetooth is successfully connected) and AUX are available. If USB or SD card is connected, the icon will be highlighted. Click the icon to access the multi-media sub-interface.

In this sub-interface, you can play the music, video record, pictures and e-book.

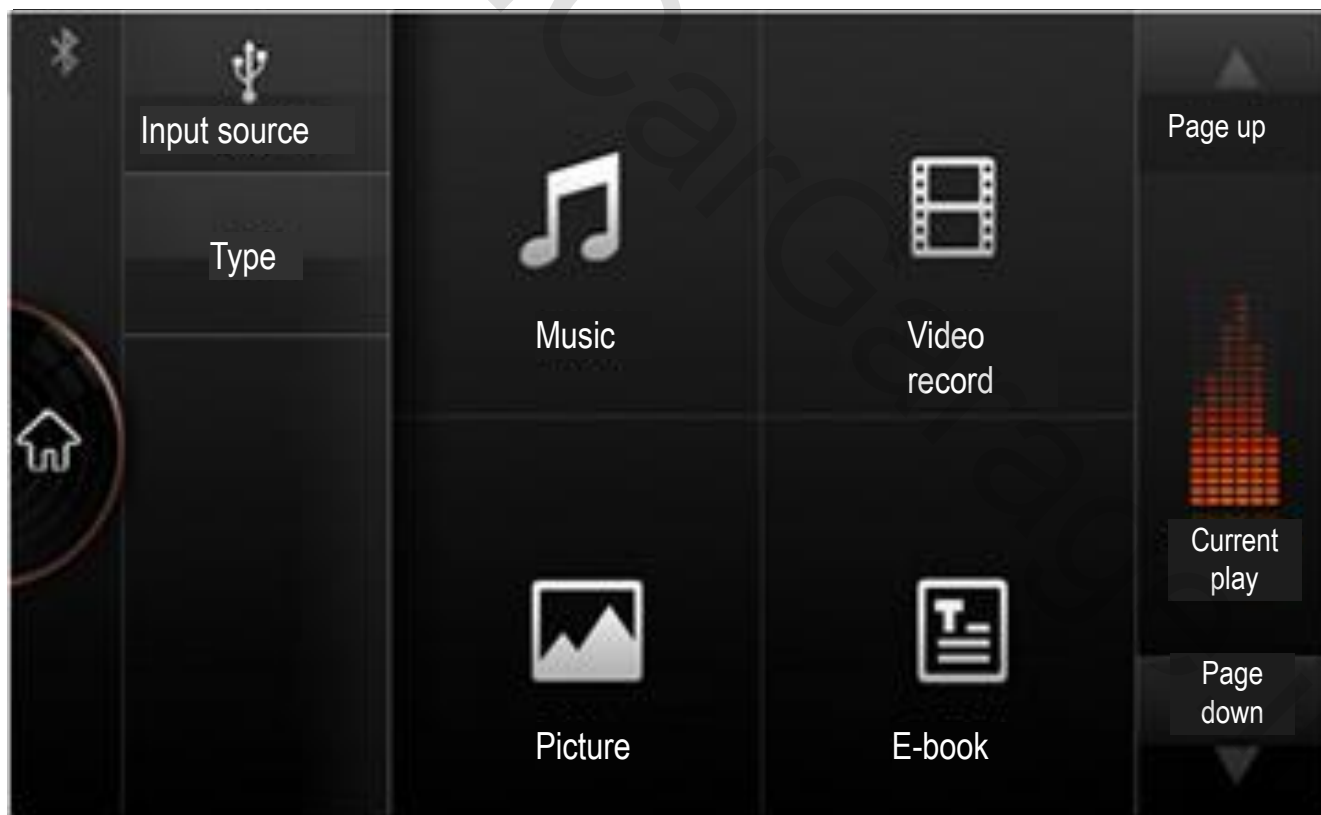

2. Operation description

Voice

Short press the voice recognition button  on steering wheel, the voice prompt interface will pop up, accompanied with the voice prompt: “Please read out the order or help”. After a ticking sound is heard, read out the voice order to realize the voice control. To realize subsequent functions, please also read out the voice order as instructed.

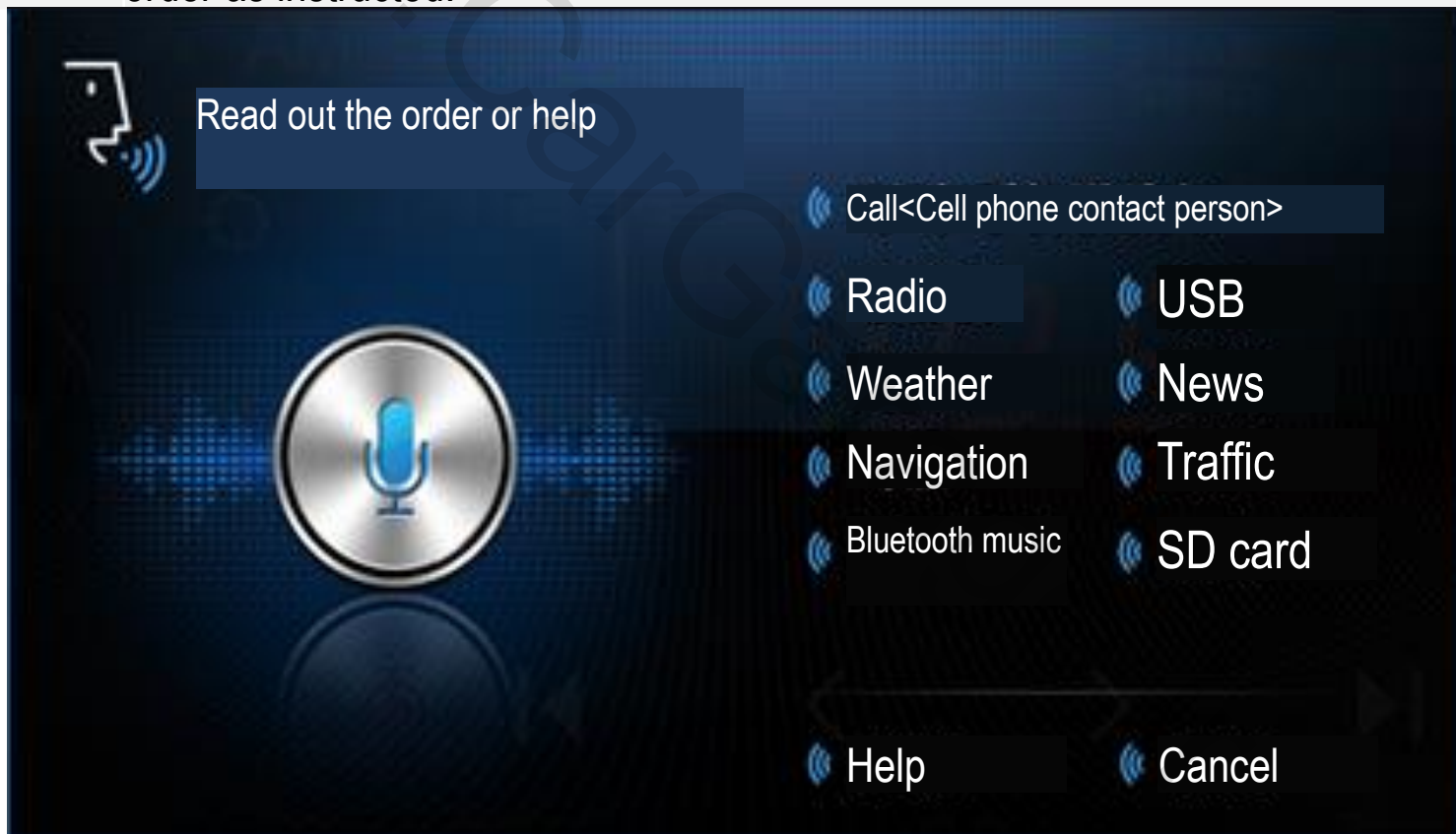

2. Operation description

Setting Click the setting icon on the main interface to access the setting interface. In this interface, following options are available: (1) Ordinary (2) Sound (3) Sound effect (4)Service (5) System



2. Operation description

Reversing
rearview

No matter whether the audio device is switched on or off, when the ignition key is turned ON and R gear is engaged, the audio device screen will switch to reversing image within 2s. When R gear is disengaged, the previous mode will be recovered.

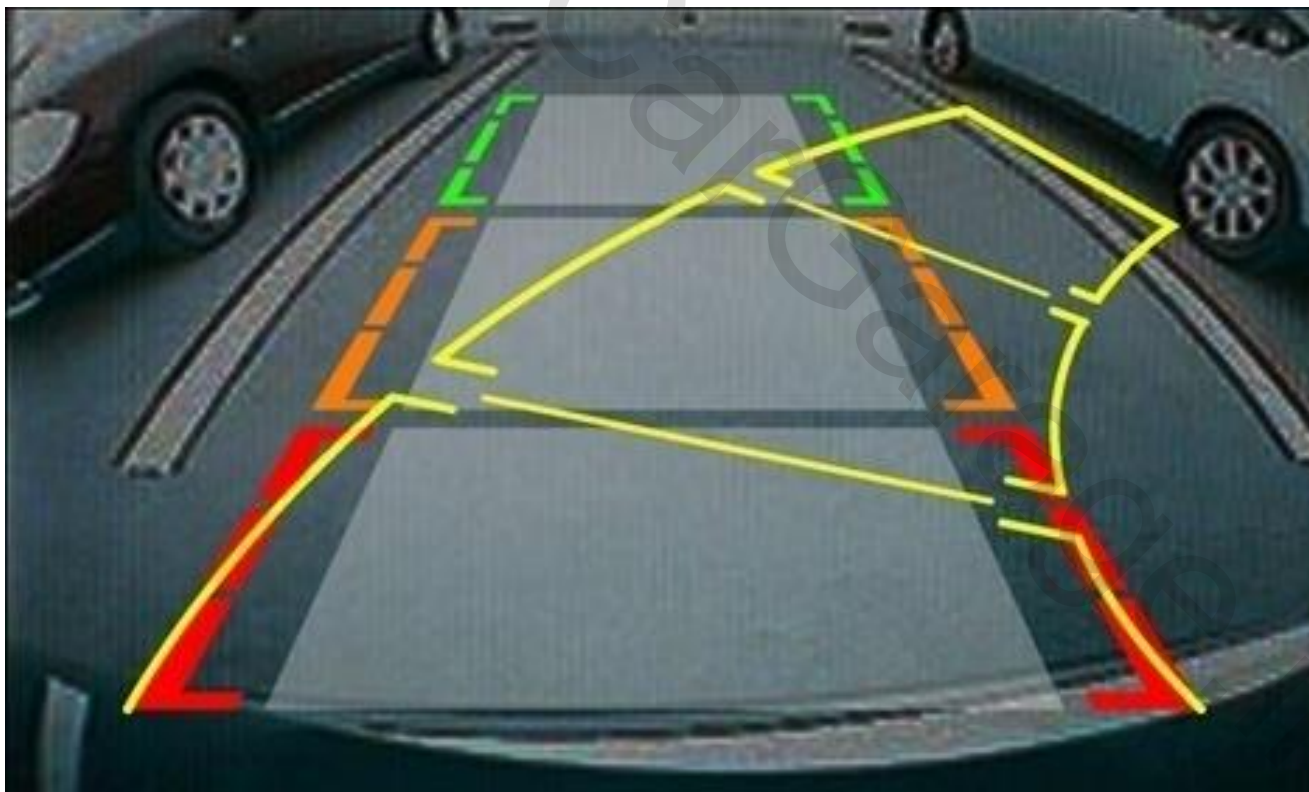

15

Reversing radar system

1. General description
2. System components

1. General description

T21 reversing radar assist system employs the ultrasonic technology.

This device can remind the driver of the distance between the car rear end and any object, and give sound prompt to minimize injuries or damages.

System composition:

Radar control module (ECU)

4 rear probes (ultrasonic sensor)

Associated components:

Ignition switch, reversing switch, BCM and instrument.

The ignition switch provides the system power;

The reversing switch provides the system activation signal;

BCM acts as a bridge among the instrument, reversing switch and radar control module;

As the terminal of the system, the instrument provides voice warning and indicates the distance.

The radar control module transfers the distance from the barrier and its location to BCM via the LIN bus, and then BCM will transfer the data to the instrument for indication and sound prompt via the CAN bus.

The LIN communication protocol is upgraded to T21 LIN_V1.3 ISSUE at the transmission rate of 9.6kBits/s.

15. Reversing radar system

1. General description

Location of module

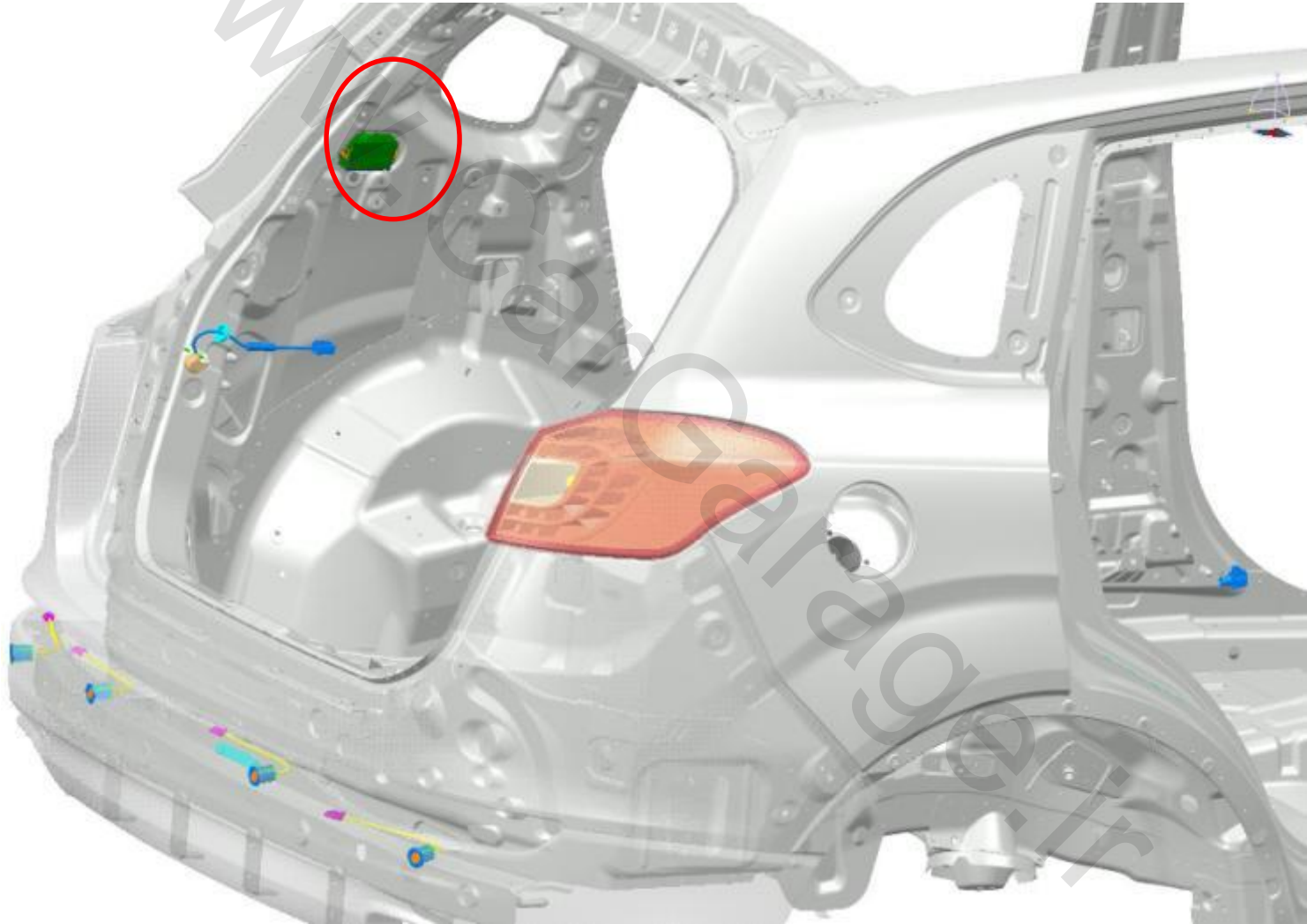

15. Reversing radar system

2. System components

Reversing signal

The signal is received by BCM and transferred to radar control module via LIN bus to activate PAS.

Basic electric parameters

Rated voltage: 13.5V;

Working voltage range: 9~16V;

Static current: 0mA

Working current: <50mA;

High voltage: $IGN-2V \leq V_H \leq IGN$;

Low voltage: $V_L \leq 2V$

Probe working frequency:

$58 \pm 1.5KHz$

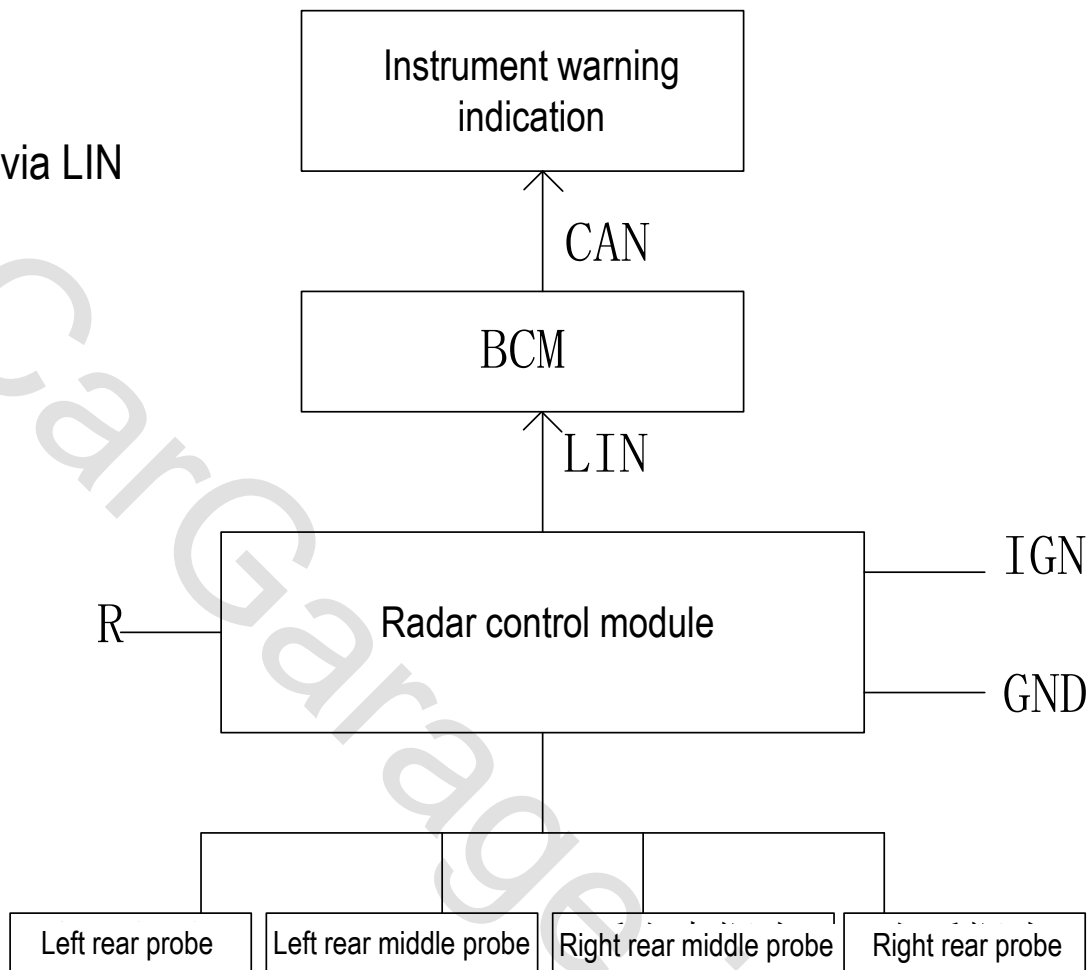

Principle block diagram of park radar assist system

2. System components

Indication and definition of warning solution

Reversing radar indication

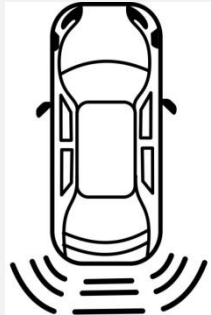

The wave in the figure represents the location of probe and the detection conditions.

If the arc line flashes, the barrier comes into the park warning zone (<35cm). The flashing frequency of arc line is 2Hz. The instrument will indicate each probe separately, and the probe nearest to the barrier will trigger the alarm.

Fault prompt: The fault information will be indicated in the text. If one system channel is not connected or is faulted (the channel connection error will be identified if the system fails to detect the probe ringing), the buzzer will ring for 2s, with the text prompt normally on; if several channels are not connected or faulted, the buzzer will ring for 2s, and the instrument will indicate the fault of each channel in a 5s cycle, without entering the normal distance measurement mode. If no fault is indicated, the normal distance measurement mode will be directly activated.

After the radar module sends an effective signal, the instrument will display the information in turn by the priority level.

16

Safety airbag system

1. General description
2. Circuit diagram analysis
3. Notices of repair and maintenance

16. Safety airbag system

1. General description

The highest configuration for T21 is a 6-airbag system.

Major components include:

- Driver airbag
- Passenger airbag
- Driver safety belt pre-tensioner
- Passenger side safety belt pre-tensioner
- Front passenger sensor
- Driver side safety belt switch
- Passenger side safety belt switch
- Airbag module
- Spiral line
- Airbag fault indicator lamp

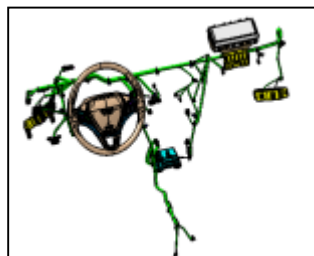
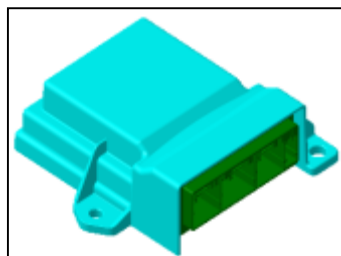

16. Safety airbag system

2. Circuit diagram analysis

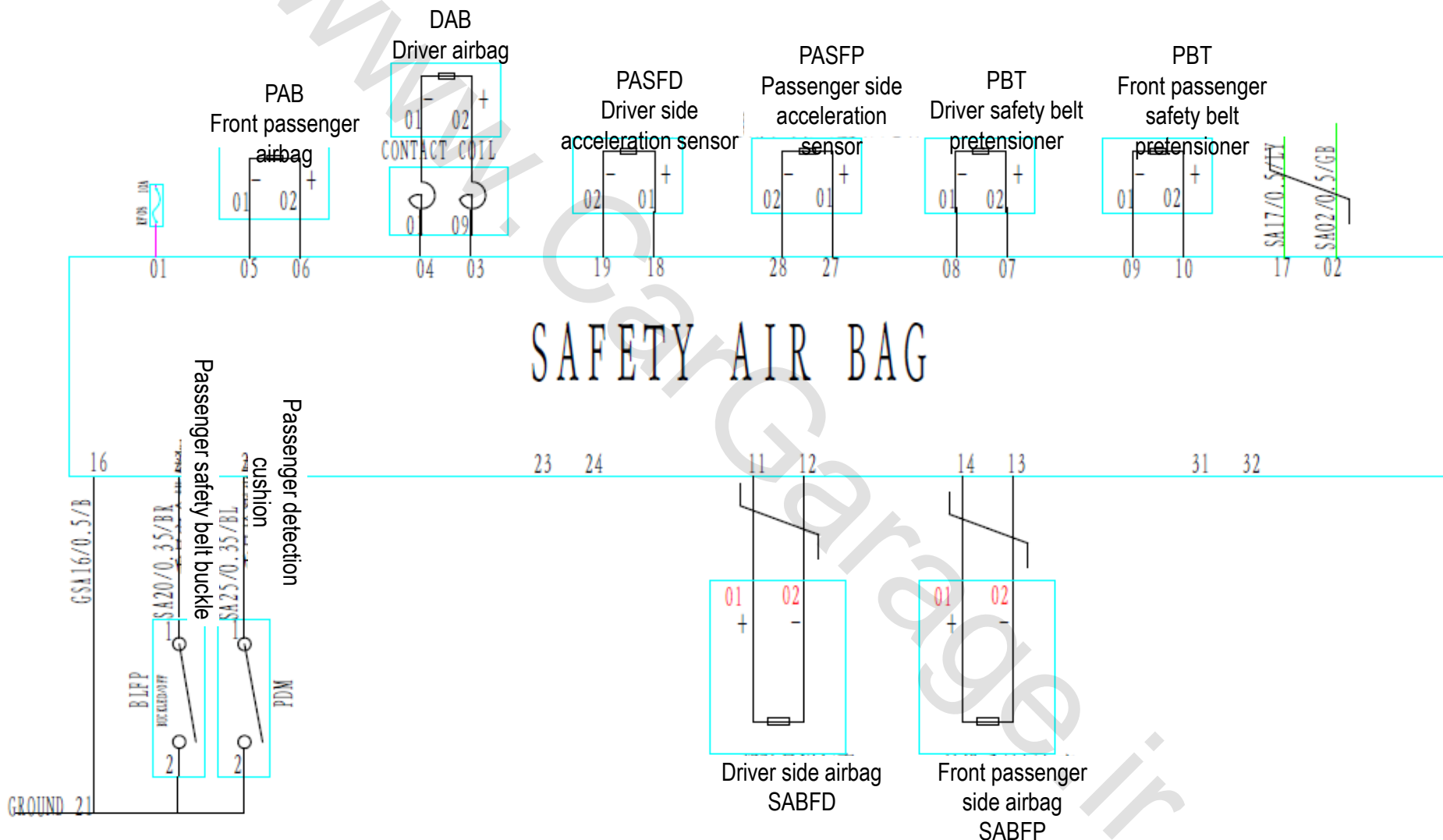

3. Notices of repair and maintenance

In the course of repair, failing to observe the correct procedure may cause unintentional explosion of the airbag to cause serious accident, or even cause failure of explosion of airbag when needed. Prior to repair (including the removal, refitting, testing or replacement of components), do carefully read following instructions, and observe the procedure stipulated in the repair manual.

(1) SRS (supplemental restraint system) failure symptoms are sometimes difficult to be diagnosed, so the fault code is the most important source of information for fault diagnosis. To diagnose SRS, always firstly check the fault code, and then disconnect the battery.

(2) Do start the repair work after the ignition key is turned to LOCK and 90s after the cable is removed from battery negative (-) terminal. This is because that the SRS is equipped with standby power supply which may cause explosion of airbag when the repair work is started within 90s after the cable is removed from battery negative (-) terminal.

(3) If SRS is not exploded even in a minor collision, it is also necessary to check the steering wheel liner, front passenger safety airbag assembly, safety airbag sensor assembly and front safety airbag sensor.

(4) During repair, if sensor may be subject to impact, it shall be removed before repair work.

(5) It is not allowed to use SRS components from other cars. If parts are to be replaced, new ones shall be used.

3. Notices of repair and maintenance

- (6) Do not remove or repair the steering wheel liner, front passenger safety airbag assembly, safety airbag sensor assembly and front safety airbag sensor to permit further use.
- (7) Avoid vibration of steering wheel liner or approach the magnet to the liner. Avoid direct exposure of steering wheel liner, front passenger safety airbag assembly, safety airbag sensor assembly or front safety airbag sensor to hot air or flame.
- (8) If steering wheel liner, front passenger safety airbag assembly, safety airbag sensor assembly or front safety airbag sensor has been once fallen, or the casing, bracket or connector is cracked, pitted or otherwise damaged, new ones shall be used. If the steering wheel liner is contaminated with grease, cleaner, engine oil or water, such liquid shall be immediately removed.
- (9) After the steering wheel liner is removed, store it steadily with the top face up. Never put any load on its top face.
- (10) When rejecting the car or steering wheel liner, do firstly have the airbag exploded by the professional organization.
- (11) After the airbag is exploded, the air charger in the steering wheel liner will become very hot, and it shall be cooled down before any operation. Never cool it using water.
- (12) The high-impedance (at least 10k Ω /V) Volt-Ohm meter shall be used for diagnosis of the circuit.

3. Notices of repair and maintenance

- (13) Instructions on the nameplate on the SRS component must be observed.
- (14) After the repair work of SRS is finished, check working conditions of SRS warning lamp.
- (15) When the negative (-) cable is disconnected from the battery, the information stored in the clock and audio system will disappear. Therefore, prior to operation, the information in various storage systems shall be recorded. After the operation, the audio system shall be reset and the clock calibrated. To avoid erasing the information in each storage system, never use the external standby power supply.

17

Electric seat

1. General description
2. Circuit diagram analysis

1. General description

- In high-configuration T21 cars, 6-way adjustable electric driver seat is provided. This electric control system is an independent system.
- The seat motor is powered by constant power supply, under direct control by the seat switch.

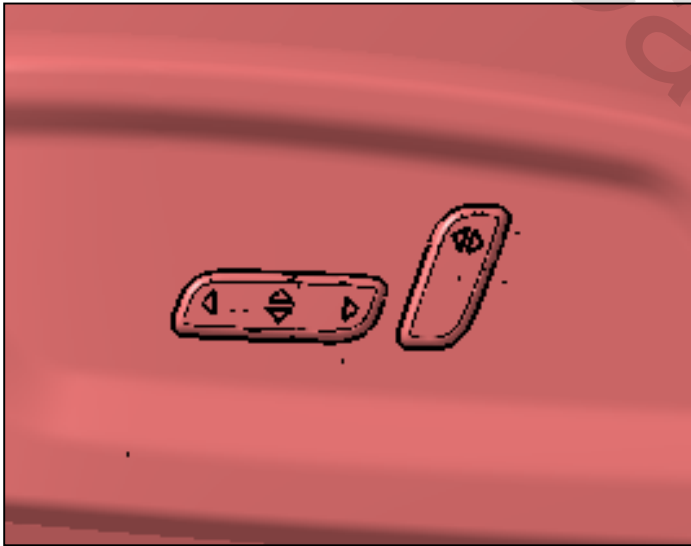

17. Electric seat

2. Circuit diagram analysis

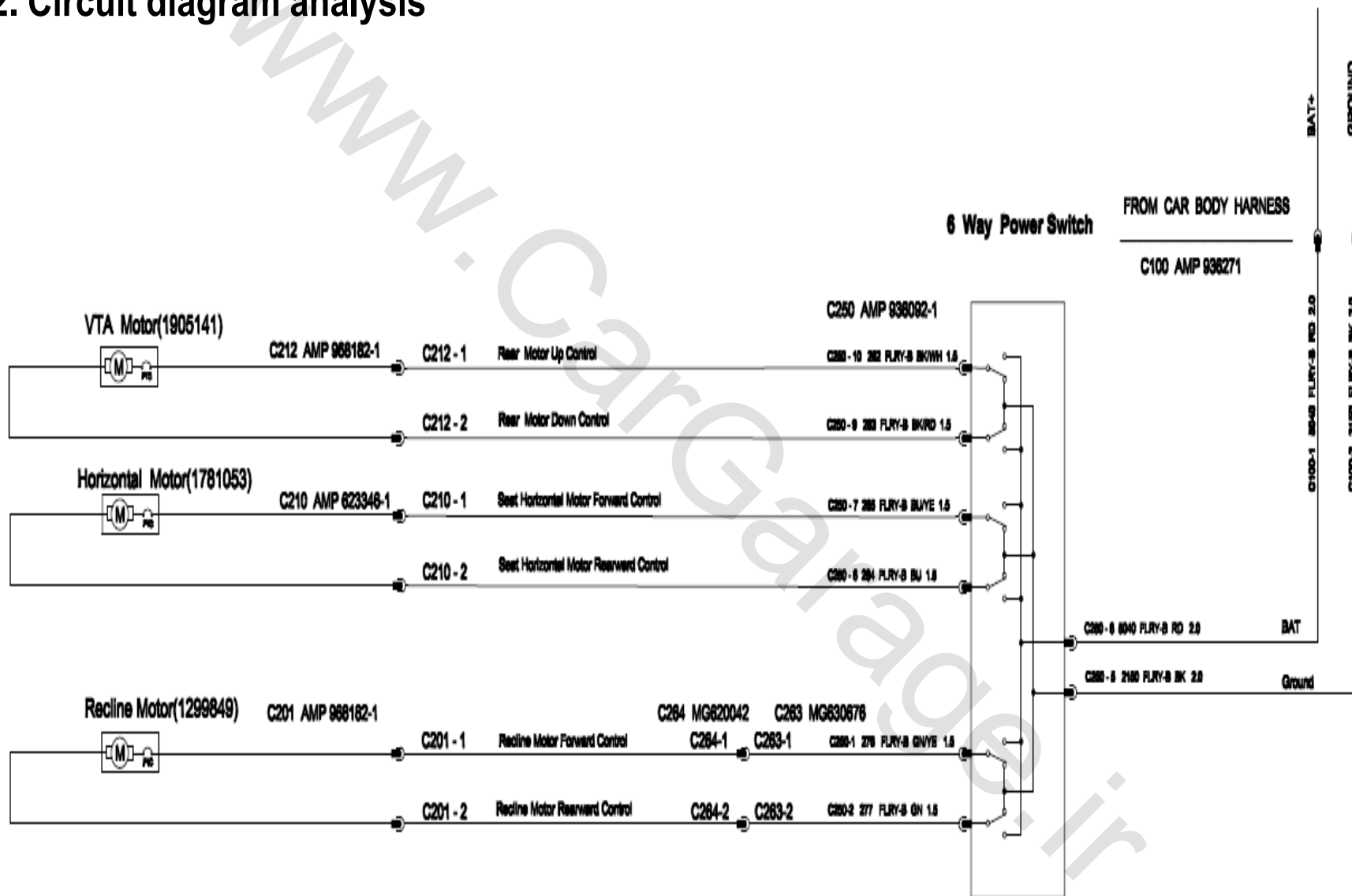



Thank you !